

NEPAL

Roadmap for the Transition from ANALOGUE TO DIGITAL TERRESTRIAL TELEVISION BROADCASTING IN N E P A L

Report



F E B R U A R Y 2 0 1 2
Telecommunication Development Sector



Roadmap for the Transition from Analogue to Digital Terrestrial Television Broadcasting in Nepal

Report

February 2012



The roadmap for the transition from analogue to digital terrestrial television broadcasting in Nepal has been prepared in the framework of the ITU digital broadcasting project in collaboration with the Korea Communications Commission (KCC), Republic of Korea. The project's objective is to assist countries in setting out a roadmap and to shift smoothly from analogue to digital terrestrial television broadcasting, and to introduce mobile television (MTV).

This report was prepared by ITU expert Mr C D Banerji with the support from the National Roadmap Team (NRT) of Nepal and the ITU Regional Office for Asia and the Pacific.

Table of Contents

	<i>Page</i>
Executive Summary	v
Recommendations	vi
Suggestions	vi
1 Introduction	1
2 Current broadcasting situation in Nepal	2
2.1 Market structure	2
2.1.1 TV.....	2
2.1.2 Radio.....	4
2.1.3 Cable.....	4
2.1.4 Satellite.....	4
2.2 Regulatory framework	5
2.3 Digital switch-over objective.....	5
3 National roadmap	8
3.1 Roadmap concept	8
3.2 Description of the construction of the roadmap	11
3.3 Selected functional building blocks for the roadmap for the regulator.....	15
3.4 Roadmap for the operator	22
4 Consideration on the ten most critical topics	29
4.1 Financial resources.....	29
4.2 Strong leadership	30
4.3 Regulatory changes	31
4.4 National frequency plan.....	31
4.5 Best content	31
4.6 Technical standards based on coverage and reception quality to suit public requirements	31
4.7 Digital dividend.....	31
4.8 Revision of National Broadcasting Act, 1993	32
4.9 Develop suitable business plan	32
4.10 Staff training.....	32
5 Recommendations	32
Annex I The National Broadcasting Act, 1993 □.....	34
Annex II TELECOMMUNICATIONS ACT.2053 (1997)	44
Annex III Report of the Frequency Recommendation Working Group □.....	64
Annex IV Details of channels: power of operation of TV channels in Nepal	78

Table of Figures

	<i>Page</i>
Figure 1: TV market structure in Nepal	2
Figure 2: Coverage map of Nepal TV and Nepal TV+	3
Figure 3: Proposed transmitter stations where the first DTTB transmitter is to be installed.....	6
Figure 4: The 70m tower at Singh Durbar, Kathmandu proposed for DTTB	7
Figure 5: Phases of the roadmap for transition to digital broadcasting	8
Figure 6: Functional layers and building blocks	9
Figure 7: Roadmap construction	10
Figure 8: Overview of the ITU Guidelines functional framework.....	11
Figure 9: Functional blocks for the regulator’s roadmap relevant for Nepal.....	15
Figure 10: Interrelation between the four phases of the roadmap for the regulator	16
Figure 11: Phase I of the regulator roadmap: DTTB/MTV policy development process.....	17
Figure 12: Phase II of the roadmap for the regulator: analogue switch-off planning process	18
Figure 13: Phase III: licensing policy and regulation process	19
Figure 14: Phase IV of the roadmap for the regulator: licence administration process	20
Figure 15: Overall roadmap for the regulator	21
Figure 16: Functional block connected to each of the four phases of network operator’s roadmap	22
Figure 17: Interrelation between the four phases of roadmap for network operators in Nepal	23
Figure 18: Phase I of roadmap for the operator: Preparations.....	24
Figure 19: Phase II of the roadmap for the operator: Planning	25
Figure 20: Phase III of the roadmap for the operator: Implementation	26
Figure 21: Phase IV of roadmap for the operator: Analogue switch-off.....	27
Figure 22: Overall roadmap for the operator.....	28
Figure 23: Overall roadmap for transition from analogue to digital TV transmission in Nepal.....	29

Table of Acronyms and Abbreviations

ABU	Asia Pacific Broadcasting Union
ASO	Analogue Switch-Off
CAPEX	Capital Expenditure
Compression	Video compression and multiplexing – the process that effectively ‘compresses’ and combines a number of previously analogue television channels into the same quantity of spectrum previously used for just one analogue television channels
DSO	Digital Switch-Over
DTH	Direct to home
DTTB	Digital Terrestrial Television Broadcasting
DVB	Digital Video Broadcasting – a European standard consortium
DVB-S	Digital Video Broadcasting-Satellite transmission standard
DVB-SI	Digital Video Broadcasting – Service Information
DVB-T	Digital Video Broadcasting – Terrestrial transmission standard
FDD	Frequency Division Duplexing
FRWG	Frequency Recommendation Working Group
FTA	Free-to-air, i.e. unencrypted
HDTV	High definition television
Head-end	The compression system at the ‘head’ of the distribution system
IP	Internet Protocol
ITU	International Telecommunication Union
ITU Guidelines	ITU Guidelines for the Transition from Analogue to Digital Broadcasting
KCC	Korea Communications Commission, Republic of Korea
MOIC	Ministry of Information & Communications
MTV	Mobile Television – broadcast based not IP based
NPR	Nepalese Rupee
NSP	National spectrum plan
NRT	National Roadmap Team
OPEX	Operating Expenditure
PSB	Public Service Broadcaster
Regulator	The government department responsible for the administration of the national broadcast environment
SAARC	South Asian Association for Regional Cooperation
SKD/CKD	Semi / complete knock-down: a kit containing the parts needed to assemble a product.
SDTV	Standard definition television
STB	Set Top Box
TDD	Time Division Duplexing
UHF	Ultra High Frequency – formally between 300-3000 MHz
VHF	Very High Frequency – formally between 30-300 MHz

Executive Summary

Nepal is a small landlocked country, surrounded by two large countries, India to the East, South and West, and China to the North. It has an area of 14 7181 km² and with a population of 28.5 million¹. The country entered the television age with the state-owned Nepal Television (NTV) in 1985. The country has at present licensed 32 terrestrial analogue TV stations. NTV has 19 transmitting stations. Three transmitters owned by private operators are also in operation. The other stations are licensed to private operators who have yet to start broadcasting. NTV is the dominant player having two channels, NTV and NTV+. The private player Kantipur Television has two stations. Lumbini community viewing TV centre is the second private operator. While NTV is operating mostly in Band III and one UHF frequency, all private players have been licensed or are operating in UHF Band IV.

NTV covers 72 per cent of the population with 50 per cent coverage of the country and NTV+ covers 40 per cent of the population and 25 per cent coverage of the country. In addition there are nine licences issued for direct to home (DTH) operation out of which only one operator is providing a bouquet of 70 channels with country-wide coverage and the rest are yet to start. There are 715 cable TV operators working throughout the country providing about 70 programme channels at a fee ranging from USD 2 to 5 per month. Kantipur Television, the major private player has two transmitters one at Lalitpur Kathmandu and the other at Namje, Dhankuta. All the terrestrial transmitters are free-to-air (FTA).

The Nepal National Roadmap Team (NRT) has developed a digital switch-over (DSO) policy for a smooth switch-over to digital in phases, conversion starting with transmitters with the highest coverage of population and each phase having coverage equivalent to that of the existing analogue transmission. Simulcast will continue within the coverage zone of a particular transmitter till at least 90 per cent of the viewers who were receiving analogue are equipped with a set top box (STB) or integrated digital television (IDTV) so that they continue to receive programmes without interruption after which the analogue switch-off (ASO) of that station takes place. The analogue equivalent digital coverage is expected to be completed in five years and complete ASO has been targeted for December 2017. The first digital experimental transmission is expected to start from Kathmandu, having the highest population, by July 2012.

The NRT has recommended DVB T2 as the digital terrestrial television broadcasting (DTTB) standard in Nepal and DVB-H as the standard for mobile television (MTV). Though standard selection has been made for MTV, its implementation will have a lower priority and would be taken up on market demand and after implementation of the DTTB plan.

The regulatory framework for licence issue in Nepal is governed by the National Broadcasting Act, 1993 for radio, TV, satellite and other broadcasting services and the National Telecommunication Act, 1995 for licensing of telecommunication services. The National Broadcasting Act, 1993 needs to be thoroughly revised in the light of transition to DTTB and introduction of MTV. The first come first served model of frequency allocation, as in the act at present, has resulted in misuse of frequency spectrum and would have to be revisited. The ownership of multiplex, regulatory provisions for sharing of the multiplex, law enforcement and execution, assignment procedures, licence terms and conditions, framework for building and infrastructure permits, and content regulation will have to be included in the legal framework and need. Such legal provisions need to be addressed as a priority.

In 2010, the Government of Nepal set up a Frequency Recommendation Working Group (FRWG) to review among other things the UHF Band IV and Band V plan of the existing national spectrum plan (NSP). The committee has submitted its report and has made some important recommendations to the government.

¹ According to the preliminary report of the central Bureau of Statistics, the country population as of June 2011 stands at 26.6 million which does not include the absentee population of 1.9 million.

So far Band III VHF frequencies and five UHF channels in Band IV are used for TV broadcasting in Nepal. The FRWG has allocated eight more UHF Band IV frequencies for simulcast mode thus allowing a total of 13 Band IV UHF channels for DTTB/MTV broadcasting in Nepal. The regulator would be required to go for public consultation and revision of the NSP in view of the above decisions.

The NRT after thorough discussion on the basis of guidelines provided by ITU has developed a roadmap applicable to Nepal. The roadmap is described in detail in chapter 3. The NRT's proactive decisions on the key parameters of the functional blocks which form the basis of the roadmap are available section 3.2.

Recommendations

The NRT would be required to take the following actions:-

- a) To get the roadmap report approved by the government.
- b) To urge the government to make the necessary legislative changes in the National Broadcasting Act, 1993.
- c) To urge the government for immediate administrative action on regulations and the setting-up of the ASO commission.
- d) To request the government for allocation of funds for the implementation of DSO and ASO policy; actions such as funding ASO commission expenditures, informing viewers of the cost of STBs to be supplied etc.
- e) To urge the government to provide duty concessions for hardware imports (including STBs), and tax concessions to private players in setting up DTTB transmitters in remote and isolated areas etc.

Suggestions

In order to fund both the DSO and ASO, the most critical elements in the process of transition, the government could auction the valuable Band III VHF.

1 Introduction

ITU has published guidelines² for the transition from analogue to digital television and the introduction of mobile television. These guidelines (ITU Guidelines) provide help to the countries to achieve smooth transition from analogue to digital television broadcasting. In order to help further, ITU has selected five beneficiary countries to assist in developing a roadmap for this transition and Nepal is one such country to receive ITU assistance.

The roadmap for the transition from analogue to digital terrestrial television broadcasting has been jointly developed by an ITU expert and the National Roadmap Team (NRT) of Nepal listed in Table 1.

Table 1: Members of the NRT

No.	Name	Organization	Designation
1.	Surya Bahadur Raut	Ministry of Information & Communications (MOIC)	Joint-Secretary (Tech.)
2.	Mahendra P. Guragain	MOIC	Joint-Secretary
3.	Pradeep R. Adhikari	MOIC	Under-Secretary
4.	Deepak Kafle	MOIC	Under-Secretary
5.	Rajesh Gautam	MOIC	Under-Secretary
6.	Anup Nepal	MOIC	Under-Secretary
7.	Gaurav Giri	MOIC	Senior Technical Officer
8.	Renu Shakya	MOIC	Technical officer/ 9741 269151
9.	Subodh Nepal	MOIC	Technical officer
10.	Ambar Sthapit	Nepal Telecommunications Authority (NTA)	D Director (Engineering Section)
11.	Deepak Mani Dhital	Nepal Television (NTV)	Act. General Manager
12.	Bishnu Ram Neupane	NTV	Head. Engineering Dept
13.	LT. Col Paras Basnyat	Nepal Army	Signal Directorate
14.	Krishna D. Dhital	Police Headquarters Communication Division	Deputy Superintendent of Police
15.	Amit Gongal	Kantipur Television Network	Deputy Chief Engineer
16.	Nirmal Kumar Pradhanang	Electronics Consultant	Japan Airport Consultants, Inc.
17.	Dr. Krishna Bahadur Ghimire	MOIC	Section Officer

However following an MOIC decision, officers from MOIC and NTV (6, 11 and 12 from Table 1) form the core team in spearheading the activities of the NRT.

Nepal has 5.1 million TV households and the TV market is a significant one considering the total population of 28.5 million having the choice of multiple platforms like terrestrial TV and satellite and cable TV each providing a choice of 70 channels.

² Guidelines for the transition from analogue to digital broadcasting – www.itu.int/pub/D-HDB-GUIDELINES.01-2010/en

The ITU assistance to Nepal consists of the following key activities:

- a) Preparation and mission to Nepal from 22 August to 2 September, 2011 for discussions with the NRT and collect information.
- b) Preparation of a draft roadmap report.
- c) Second mission to present and discuss the draft roadmap report from 23 to 27 September 2011.
- d) Drafting of the final report.

During the first visit the expert and the NRT took stock of the broadcasting situation in Nepal particularly that of TV broadcasting and associated regulatory provisions. An overview of the short term and long term DSO strategy was undertaken by the NRT. An inventory of decisions on key points of the ITU Guidelines functional framework relevant for Nepal was made. The methodology for drafting the roadmaps both for the regulator and the operator was discussed and the NRT was requested to prepare the roadmaps. The draft report and the roadmaps were also prepared by the expert and the contributions made by the NRT were discussed during the second mission. This resulted in an agreed report "Roadmap for the transition from analogue to digital terrestrial television broadcasting in Nepal".

In section 2 of this report, the current broadcasting situation in Nepal and the digital switch-over strategy is discussed. Section 3 deals with the draft roadmap report in achieving the DSO objectives. Section 4 deals with the top ten critical topics and choices.

The National Broadcasting Act, 1993, the National Telecommunication Act, 1995, the report of the Frequency Recommendation Working Group, whose findings and observations are referred in this report, are available in annexes I, II and III of this report. Annex IV gives a list of terrestrial channels and power of operation of TV channels in Nepal.

2 Current broadcasting situation in Nepal

Figure 1: TV market structure in Nepal

The TV market structure in Nepal is shown as in the table below:

Service	Mode	Content Creator	Content aggregator	Multiplex operator	Service provider	Content distributor	% of Pop covered	Million viewers/ week
PSB	T	Nepal Television			Nepal Television		72%	
PSB+Com	T	Nepal Television+			Nepal Television+		40%	
Com	T	Kantipur Television			Kantipur Television		Kathmandu+Dhankutta(Part)	
Community	T	Lumbini TV			Lumbini TV		Lumbini(partial)	
Com	C	715 Cable Operators			715 Cable Operators		nearly 90%	
Com	S	Dish Media DTH operator			Dish Media		nearly 100%	

Source: NTV

2.1 Market structure

2.1.1 TV

Nepal Television (NTV) is the only entity that provides terrestrial television broadcasting across the country. It was established by the government under the sixth national five year plan in January 1985 with a view to enhancing country's socio economic development. It covers 72 per cent population and 50 per cent area. In addition NTV Plus has also been set up in the year 2004 and it covers 40 per cent population and 25 per cent area. NTV uses mostly VHF frequencies in addition to one UHF frequency.

Private broadcasters mostly use UHF frequencies. There are 32 TV stations licensed all over the country out of which 19 stations belong to NTV/NTV+ and the rest are to be operated by private operators. Details of the channel power etc. of operation of all the TV channels in Nepal are provided in Annex IV. The TV services are provided in analogue mode in PAL B in VHF and PAL G in UHF. Kantipur and Lumbini TV are important terrestrial private operators.

The major players in television, Nepal TV and Nepal TV Plus, have their studios in Singh Durbar area in the heart of the city. They have one 300 m² studio with four cameras, one 120 m² studio with three cameras and two more 80 m² studios with three cameras each. Two outside broadcasting vehicles one with seven cameras and the other with four cameras are used for outside broadcasting purposes and feeds are sent to the studios with the help of fibre optic links or microwave links. One digital satellite news gathering (DSNG) terminal is also there for field coverage. The main transmitters 5kW in channel 5 for NTV and 2 kW in channel 8 for NTV Plus are located at Phulchowki and provide substantial coverage of Kathmandu Valley and surrounding areas in hilly and mountainous regions. The standby transmitters for both the services are located in the Studio complex at Singh Durbar. National coverage is established through satellite link (Thaicom 5) in extended C band. About 400 permanent staff and 100 trainees man NTV's 19 stations. NTV's transmitter and studio equipment are very old and it would be better for them to augment facilities when changing over from analogue to digital. Figure 2 gives the coverage map for Nepal TV and Nepal TV +.

Figure 2: Coverage map of Nepal TV and Nepal TV+

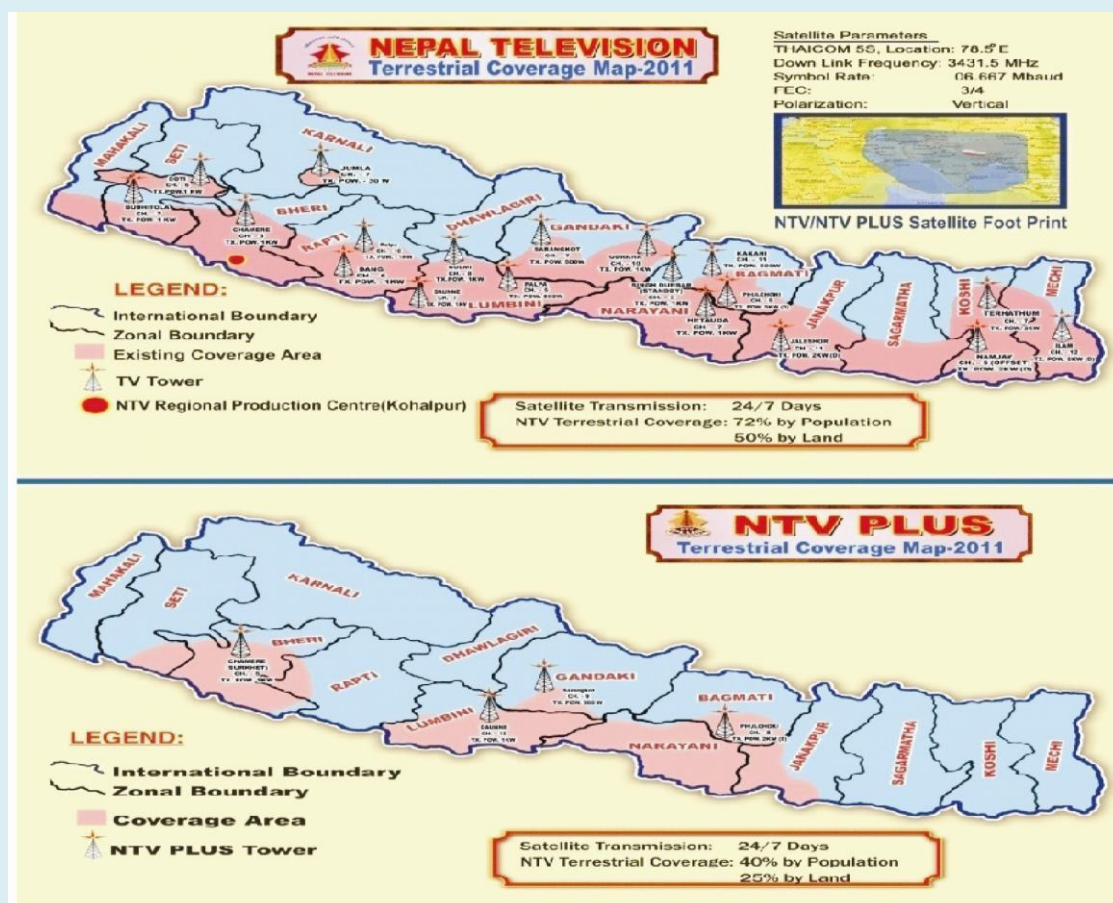

Source: NTV

Kantipur Television, a private operator has two licences for a terrestrial transmitter. One transmitter is at Lalitpur, Kathmandu and the other is at Namje, Dhankutta. Kantipur TV has production studios, of 250 m² and 200 m² each with three cameras and associated production equipment.

2.1.2 Radio

Medium wave radio

Nepal has four Medium wave AM transmitting stations of 100 kW power each, located at Kathmandu working on 729 kHz, at Pokhra on 684 kHz, at Surkhet on 576 kHz, at Bharan on 648 kHz carrying National service networked through V SAT carrying the same programme. In addition there are two 10 kW medium wave transmitters located at Bamiwar working on 1143 kHz and at Dipayal working on 810 kHz. Radio Nepal first started its operation in 1983 in Kathmandu. Regional stations started in 1990 and in 1991 the Kathmandu transmitter was replaced with a solid state transmitter. Radio Nepal has five new studios and four old studios in Singh Durbar area of Kathmandu. The studios are used for production of drama, music, news etc. Radio Nepal earns 20 to 30 per cent of its running expenditure by advertisement and leasing its facilities to BBC. Radio Nepal has 600 employees.

Short wave radio

Nepal Radio has also a 100 kW shortwave transmitter working on 5005 kHz for covering the country specially the hilly terrains which are otherwise not reachable by other means.

FM radio

Nepal has a very strong FM network consisting of 449 FM transmitters spread all over the country. Out of these only 46 transmitters are of Power 1 kW and above. Rest of them are low power stations of power 500w and less. There is only one 10 kW high power transmitter operated by a private operator, Kantipur Radio located, in Dhankuta. The FM stations could be classified into two categories: a) Networked FM b) relay transmitters. There are four major content providers who provide news content, social programmes, and programmes by donor agencies etc. through satellite (Thaicom). Previously, networking was through leased line. There are three major national broadcasters namely Radio Nepal, Kantipur Radio and Image Channel. Broadcasting of BBC programmes is also done through the networked station. Radio Nepal has 18 FM stations all over the country.

Government earns substantial revenue from the FM sector. In order to receive a licence for both broadcast rights and operation rights for a FM transmitter upto 500 W power, a sum of NPR 500 000 is charged and annual renewal fee of 10 per cent of the initial licence fee must be paid. In addition, every licensee has to pay 2 per cent of total income as royalty fee.

2.1.3 Cable

There are nearly 715 cable TV operators in Nepal out of which ten are operating in Kathmandu. The subscription fee of cable connection is USD 5 per month in Kathmandu and USD 2 in other areas. The cable operators mostly receive signals from satellite or programmes off air and distribute through cable.

2.1.4 Satellite

License for DTH service was provided to nine DTH operators out of which two only started operation. But ultimately they merged into one entity named Dish Media and currently in operation. The rest hold the licence but no one knows whether they will start operation or not. The DTH operator uplinks through Intelsat 906 through the uplink station at Lalitpur (main), Kathmandu and back-up uplink station at Balwata.

2.2 Regulatory framework

The regulatory framework for issue of licence is governed by 1) The National Broadcasting Act, 1993 for Radio, TV, Satellite and other broadcast services, and 2) National Telecommunication Act, 1995 which deals with licensing of telecommunication services. Copies of both the acts are provided in Annex I and Annex II. Section 6 of the National Broadcasting Act deals with the issuance of broadcast licences. Section 5 of the Act states that any person desiring to apply for a licence has to apply for it in a prescribed form with a fee and upon examination, if found suitable will be provided one on the basis of first come first served (FCFS). The Act also provides for the power to prevent broadcasting and to cancel licences (see section 7 and 8 of the Act).

Section 24 of the National Telecommunication Act provides the methodology for issuing of licence for telecommunication services. The Act also provides for conditions for the sale and transfer of the licence (see section 25 of the Act) and also how to make amendments. Similarly section 28 provides for details regarding cancellation of the licence. Unlike broadcasting, in telecommunications, if requests from more than one applicant are received, assignment is done on the basis of the highest bidder i.e. similar to public tender policy and not the FCFS policy of broadcasting.

The National Broadcasting Act, 1993 would be required to be revised in the light of the introduction of DTTB/MTV services in the country. Government of Nepal had set up a Frequency Recommendation Working Group (FRWG) in 2010 (see Annex III) to review amongst other thing the UHF Band IV and the Band V frequency plan of the existing national spectrum plan (NSP). The committee has submitted its report and made important recommendations. So far Band III VHF channels and five UHF channels have been used in Nepal for TV broadcasting. The FRWG has allocated eight more UHF channels for DTTB in simulcast mode thus allowing a total of 13 UHF channels in Band IV available for DTTB/MTV broadcasting in Nepal. The regulator would be required to complete a public consultation and revise the NSP in the light of the above decisions.

DTTB has an additional element, a multiplex. Unlike analogue, where one transmitter could broadcast one programme per channel, the same DTTB transmitter would transmit more than one programme in standard definition television (SDTV) mode and hence is called a multiplex. The ownership of the multiplex has to be defined and the sharing criteria for the multiplex have to be worked out. In a meeting with the regulator, it has been clarified that Nepal would at present have one multiplex and the regulator would be the owner in the majority of cases operated by NTV barring a few cases of dominant private players who could be multiplex owners. However any participant in the multiplex would have to obtain broadcast rights from the regulator. The regulation regarding the sharing of the multiplex, the law enforcement and execution, assignment procedures, licence terms and conditions, framework for grant of building/infrastructure permits etc. will have to have legislative provisions and necessary action would have to be taken as early as possible. The National Broadcasting Act's existing FCFS policy for issuing licences has been misused by private broadcasters, where as many as ten licences have not been made operational even after a lapse of considerable time. Hence a relook in the licensing procedure is called for.

2.3 Digital switch-over objective

Out of Nepal's total population of 28.5 million nearly 10 per cent i.e. 2.7 million live in Kathmandu. The most populated cities/towns after Kathmandu are: Biratnagar 0.5 million; Pokhara 0.35 million; Janakpur 0.3 million; Birtamod, Jhapa 0.25 million; Butwal, Rupendehi 0.25 million; Napalgunj, Banka 0.20 million; Mahendranagar, Kailali 0.20 million; Hetauda, Makawanpur 0.15 million. The terrain in Nepal could be broadly classified into flat lowlands, and hilly and mountainous areas. People live in scattered communities in the mountainous and hilly areas.

In view of the population pattern, it has been decided to have a DSO strategy of covering first the most populous area and gradually lesser populated areas. This will help the administration to spread the total capital expenditure over a period of time. Also the expertise generated in the first few stations will be helpful for the rest. The simulcast will continue in the stations which are switched over to digital till

viewers are fully equipped with STBs or IDTVs. The first digital transmitter is expected to be set up in Kathmandu in 2012 for which the necessary preparation has already started. Funds for a 1 kW DTTB transmitter has already been provided. It is expected to be operational by July 2012. The transmitter hall of the standby transmitter in Singh Durbar area and the existing 70m tower there has been proposed for installation of the DTTB transmitter. Figures 3 and 4 show the transmitter station and tower to be used for the first DTTB transmitter in Nepal.

Figure 3: Proposed transmitter stations where the first DTTB transmitter is to be installed



Source: NTV

Figure 4: The 70m tower at Singh Durbar, Kathmandu proposed for DTTB



Source: NTV

Thereafter in the second and third phase, four to five transmitters etc. are expected to be set up with the ASO set for 2017. The stations to be converted to DTTB in the order of decreasing population are indicated below:

Table 2: Phasing of NTV and NTV+ TV transmitter transition to Digital

Phase	Transmitter locations	Target	Phase	Transmitter locations	Target
1	1. Kathmandu TV , Singh Durbar	2012		11. Ilam	2015
2	2. NTV+ TV , Phulcowki	2013		12. Hetauda	2015
	3. Kakani	2013		13. Gorkha	2015
	4. Namjay	2013	5	14. Palpa	2016
	5. Terathum	2013		15. Gulmi, Arjun Danda	2016
3	6. Daunee	2014		16. Rolpa	2016
	7. Sarangkoat	2014		17. Doti, Bhatani, Danda	2016
	8. Dang Chaupatta	2014	6	18. Bhuditola, Kailali	2017
	9. Chamera	2014		19. Jumla	2017
4	10. Jaleswor	2015			

Source: NTV

The existing TV coverage with the analogue transmitters is at least to be achieved by the digital transmitters and viewers are to be equipped to receive digital transmission before ASO could be declared for a particular transmitter.

3 National roadmap

Section 2 of this report has dealt with the aim of the roadmap report and this section will now discuss the roadmap followed by the description of the construction of the roadmap in section 3.2. Section 3.3 shows the selected functional building blocks for the roadmap of Nepal. Section 3.4 describes each of the phases of the roadmap for Nepal. The national roadmap will deal with the digital terrestrial transmission however, the MTV part has been left out due to its lower priority at this point in time.

3.1 Roadmap concept

A roadmap is a management forecasting tool and is directed to the implementation strategy and related to project planning. A roadmap consists of various phases, normally related to preparation, development and implementation of the strategy. A roadmap is often presented in the form of layers and bars, together with milestones on a time scale. Phases of a roadmap for transition to digital broadcasting are shown in Figure 5.

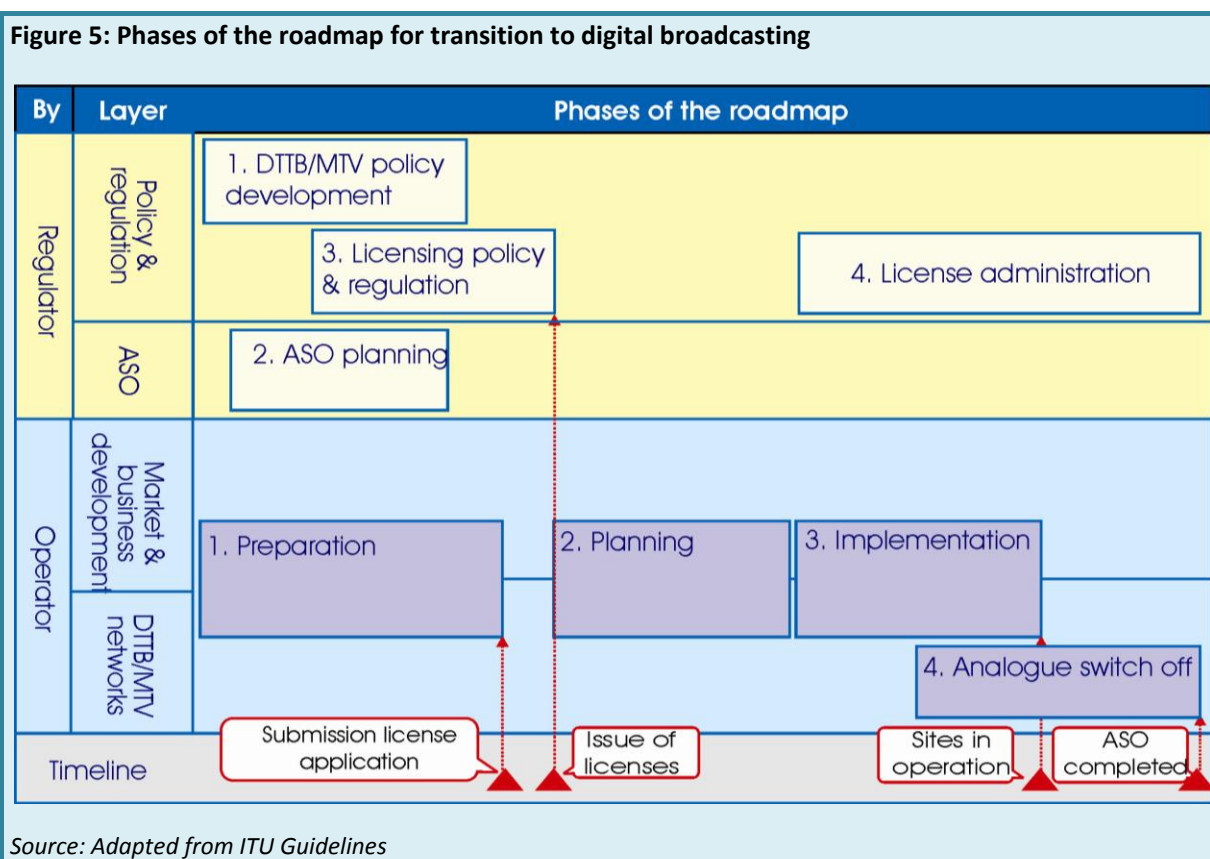

The ITU Guidelines for transition to digital television describe a method for developing a roadmap for transition to digital television. This methodology will be followed in the development of the national roadmaps. The basis is a functional framework consisting of five layers (see Figure 6).

Figure 6: Functional layers and building blocks

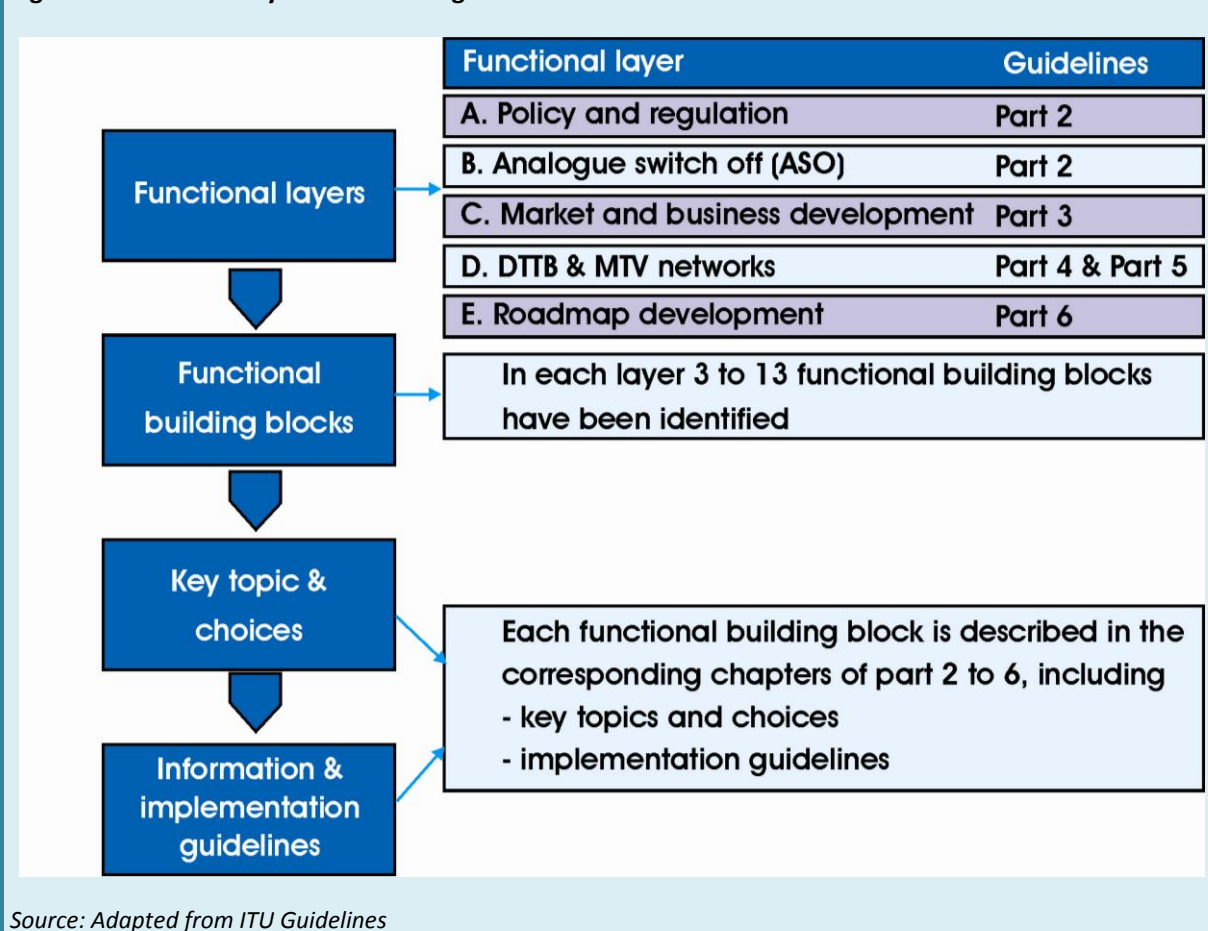

Each layer consists of a number of functional building blocks covering all functionalities relevant to the transition to digital television.

Development stages

Figure 6 shows the stages in the development of a roadmap. These stages will be described in the following paragraphs.

1. Consideration of functional layers and selection of functional building blocks

Depending on the national situation, taking into account the actual status of transition to digital television and the scope of interest of the National Roadmap Team, the relevant functional layers and functional buildings blocks should be selected.

2. Consideration of key topics and choices

The selected functional building blocks and the information received regarding key topics and choices related to the functional building blocks will be summarized in a checklist guided by available information. Key topics and choices will be addressed during the first visit in discussions between the NRT and the experts.

In considering the key topics and choices of the relevant functional building blocks, it should be determined if the issues are:

- partly decided;
- not considered or decided yet;

- in need of revision;
- decided already.

In discussing key topics and choices that are partly decided or not decided yet, it may be possible to make some decisions based on the available information, the overall national strategy, or as a consequence of other choices. However, it should be noted that for those principle decisions further work may be needed. These further activities should be listed. For most of the key topics and choices the NRT will have to carry out investigations before a decision can be made. In these cases, the necessary activities for the NRT should be identified.

3. Construction of a national roadmap

The results of the discussions of the first visit will be analysed and a draft roadmap will be prepared for those parts that are in scope of interest.

The steps needed to construct the national roadmap are shown in Figure 7.

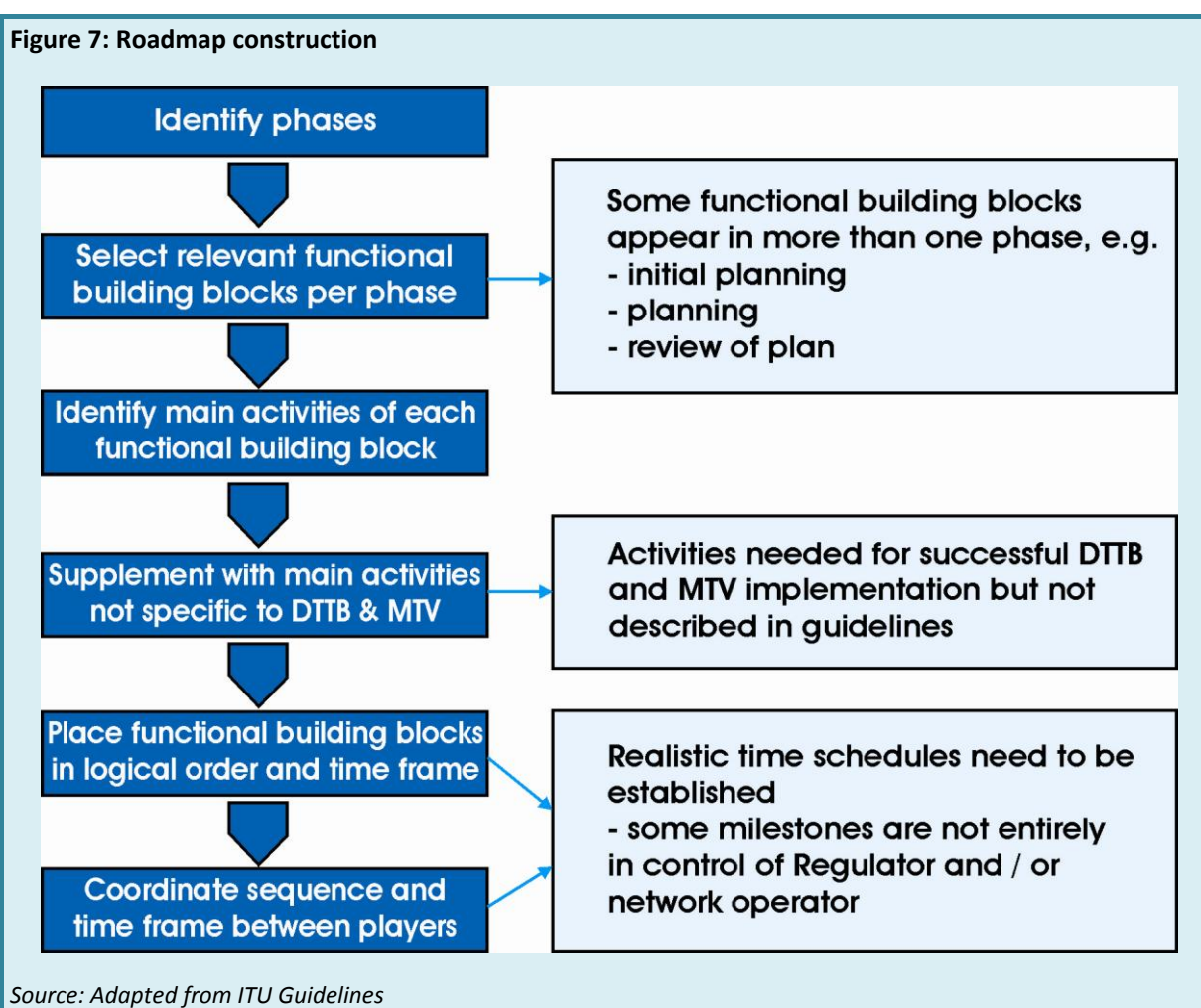

In constructing the roadmap the following steps should be taken:

1. Identify the roadmap phase in which the national process of transition to digital television currently takes place and the phases that still need to be carried out.
2. Place the relevant functional building blocks in the phases that still need to be carried out. It should be noted that certain functional building blocks may appear in more than one phase.

3. Identify the decisions already taken and activities that need to be carried out in order to be able to take the still pending decisions.
4. Note activities that are needed for successful implementation that are not specific to DTTB and MTV implementation and not described in the ITU Guidelines for transition to digital television.
5. Place the functional building blocks, together with the listed activities, in logical order and a time schedule to complete the process.

3.2 Description of the construction of the roadmap

The ITU Guidelines has identified 41 functional blocks in five functional layers as illustrated in Figure 8.

Figure 8: Overview of the ITU Guidelines functional framework

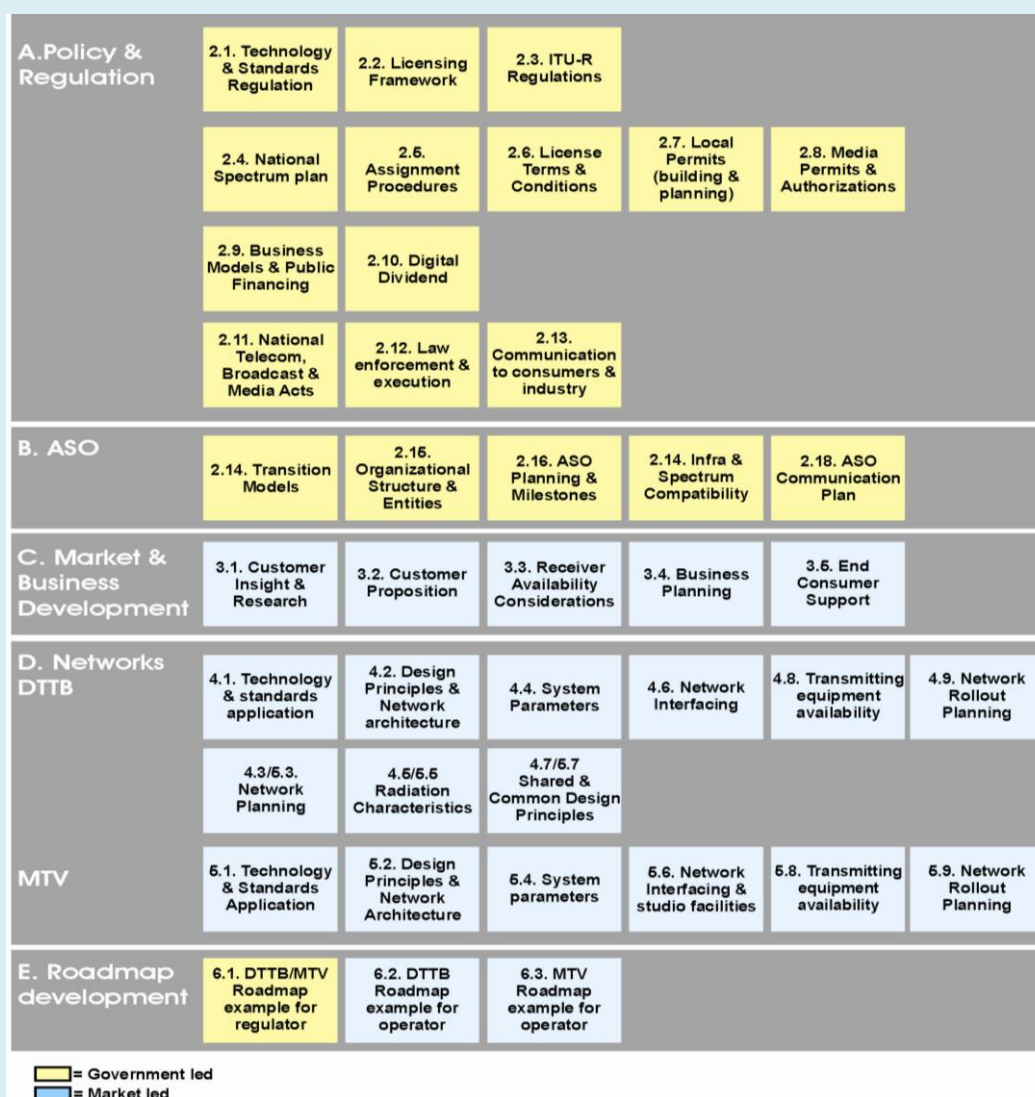

Source: Adapted from ITU Guidelines

The above functional blocks or planning activities are grouped into five functional layers starting with the policy and regulation layer and ending with the roadmap development:

- A. The same planning activities are further split into two categories depending upon whether they are government led or market led.

- B. The functional layer policy and regulation indicates planning activities normally undertaken by the government and considers key issues and choices faced by the regulator with output such as new policies, new funding, licences, permits and new regulations.
- C. The analogue switch-off functional layer of planning activities is normally taken up by the government and normally considers the process of turning off the analogue transmission after the service area of the transmitter is served with a digital signal without causing any disruption of service resulting in a smooth change over.
- D. The market and business development functional layer of planning activities normally undertaken by companies in the local television market place considers key issues faced by service providers, network operators, retailers, manufacturers when planning commercial launch of DTTB/MTV services.
- E. The network functional layer of planning activities normally taken up by the operator considers key issues of planning parameters for the DTTB transmitter.

Table 3: Decisions of the NRT on key points of the functional locks

Functional blocks	NRT key point decisions
2.1 Technology and standards regulation	<p>The following decisions were taken:</p> <ul style="list-style-type: none"> a) presentation format: SDTV for the time being. b) TV standard: DVB T2/ DVB-H³ c) compression standard: MPEG-2 and MPEG-4. d) application programme interface: MHP. <p>Rest of the specification of ERP, FTT, G/I, FEC, modulation etc. would be chosen later depending on planning considerations.</p>
2.2 Licensing framework	<p>Action regarding:</p> <ul style="list-style-type: none"> a) spectrum rights. b) broadcast rights. c) operating rights will be started immediately and rules framed depending on requirements. d) public sector broadcaster will have overriding priority. e) along with rights, obligations will be defined. <p>Framing of rules and legislative support will be started immediately and completed within one year from November 2011.</p> <p>However if legislative support is required then setting the time frame will be difficult as parliament has to change relevant acts.</p>
2.3 ITU-R Regulation, and 2.4 National spectrum plan	<ul style="list-style-type: none"> a) work out frequency plan for DTTB/MTV out of 13 UHF channels given. b) determine pricing mechanism of frequency in Band III to be vacated. <p>It was decided that action will be completed by July 2012.</p>
2.5 Assignment procedure	<p>It was decided that during the time of actual execution either public tender (beauty contest) or auction will be adopted</p>
2.6 Licensing terms and condition	<p>Define licensing terms and conditions and seek legislative support if required. This may not need legislative support, Cabinet decision would be enough. Target date: July 2012.</p>
2.7 Local permits	<p>It was decided that local permits for building/infrastructure would be made available. To facilitate sharing and fair pricing of infrastructure – rules regarding:</p> <ul style="list-style-type: none"> a) reduction of horizontal pollution, and b) safety from health hazards, EMC, dangerous goods etc., <p>it was decided that these rules are administrative decisions and will be completed in a</p>

³ Ministry of information and communication (MOIC), Government of Nepal, took a decision on DTTB and MTB standard on 20 July 2011 and made it public (see public notice dated 3 September 2011).

Functional blocks	NRT key point decisions
	year's time.
2.8 Media permits and authorization	Regarding: a) eligibility condition of applicant; b) granting of broadcast rights whether at programme level or multiplex level; c) content obligation; d) applicability of CA etc., similar subjects are being dealt with for the DTH platform and rules are being framed. These items are to be included in the regulation and expected to be completed in one year from November 2011.
2.9 Business model and public financing	Regarding how to: a) finance DSO/ASO of public service broadcaster; b) finance STB/digital receivers; c) finance simulcast mode; it was decided to have the following models: a) auctioning of Band III frequencies vacated after ASO - substantial funds are expected to be generated by selling 56 MHz (very useful spectrum). b) requesting government to reduce import tax/duty, relief on customs duty for importation of transmitter equipment, STBs/IDTVs etc.
2.10 Digital dividend	The Band III frequency vacated after ASO is the digital dividend and could be utilised to fund DSO/ASO strategy.
2.11 National telecom/broadcast and media act	All actions in 2.1 to 2.10 should conform to the Nepal Telecommunications Authority (NTA) and broadcasting act. Review of these acts has already been undertaken. DTTB inputs will be given to the committee which is reviewing these acts. Government has appointed the JS (Administration) as the chairman of that committee and the job is expected to be completed by one year from November 2011.
2.12 Enforcement and execution	Proposal to have engineering and administrative set up to execute these functions is being included in the broadcasting act and expected to be completed by November 2012 but since it is an act and parliament has to consider it, it is very difficult to propose a firm date at this stage.
2.13 Communication to end customer and industry	This function will be entrusted to ASO commission to be set up.
2.14 Transition model	In view of DSO strategy of conversion from highest population centres downwards and switching off simulcast operation after viewers are supplied with STBs/IDTVs in the coverage area of that centre, the ASO will be carried out in a phased manner. The UHF frequency for the simulcast mode has been earmarked. The ASO commission is being set up. Funds will be provided to the commission for provisions of STB etc. The operation is expected to be spread over a period i.e. from 2012 to 2017.
2.15 Organizational structures and entities	The ASO commission is being set up with a very senior level officer of the government as its chairman and having members from advertisers, viewers, retailers, government, broadcasters, suppliers etc. This is expected to be in position by July 2012 at the latest.
2.16 ASO planning and milestones	When to start? Activity should start in November 2011. ASO approach and simulcast mode? It would be simulcast mode. Contract Centre Management to help customer: ASO commission to be entrusted with this work.
2.17 Infrastructure and spectrum compatibility	To be sorted out during planning stage; multiplex sharing conditions to be taken care of through regulation as well as infrastructure compatibility.
2.18 Consumer insight and research	To be dealt with by the commercial wing of the respective broadcaster. NTV has a commercial wing already.
3.1 Consumer's insight and research, and 3.2: Market research methods	To be dealt with by the existing commercial wing of the broadcaster.
3.3 Receiver availability	The ASO commission who will be given sufficient funds for providing STB etc. will look into this aspect.

Functional blocks	NRT key point decisions
3.4 Business planning	The public sector broadcaster will use free to air mode and advertisement will be the source of revenue. For commercial stations, it would be advantageous, plus pay TV model. Conditional access (CA) would be required by them. Rules are under preparation for DTH. The same committee will be given inputs regarding DTTB for framing rules regarding CA.
3.5 End customer support	The ASO commission will be entrusted to take care of this issue.
4.1 to 4.5: Technology and standards application; Design principles; Network planning; System parameters; Radiation characteristics	DVBT2, SDTV for the time being, CA system, single multiplex to start with, designing system and network as per DSO strategy, other system parameters after experience with experimental set up in Kathmandu.
4.6 Network interfacing	Optical fibre link for studio transmitter or head-end; SDI interface between std equipment and encoder etc.
4.7 Shared infrastructure	A single multiplex to start with and lower priority for MTV. To be decided at the time of execution of project.
4.8 Transmitting equipment availability	Action has already been initiated for the pilot project in Kathmandu. The pilot project is expected to come up in six months' time.
4.9 Network roll out planning	Pilot project execution and testing will give experience in optimising parameters to get best results and roll out planning would be realistic and efficient.
5.1 Technology and standards application for MTV	DVB-H has been chosen as the standard. But MTV has been given a lower priority due to 3G in telecommunication mode. Experimentation would be carried out in the pilot project and experience gathered.
5.2 to 5.9	Will be in line with ITU Guidelines. Parameters etc. will be decided later. Based on the decisions of NRT Nepal, the roadmap for transition from analogue to digital TV broadcasting has been prepared. Two roadmaps one for the regulator and the other for the operator have been developed.

3.3 Selected functional building blocks for the roadmap for the regulator

Figure 9: Functional blocks for the regulator’s roadmap relevant for Nepal

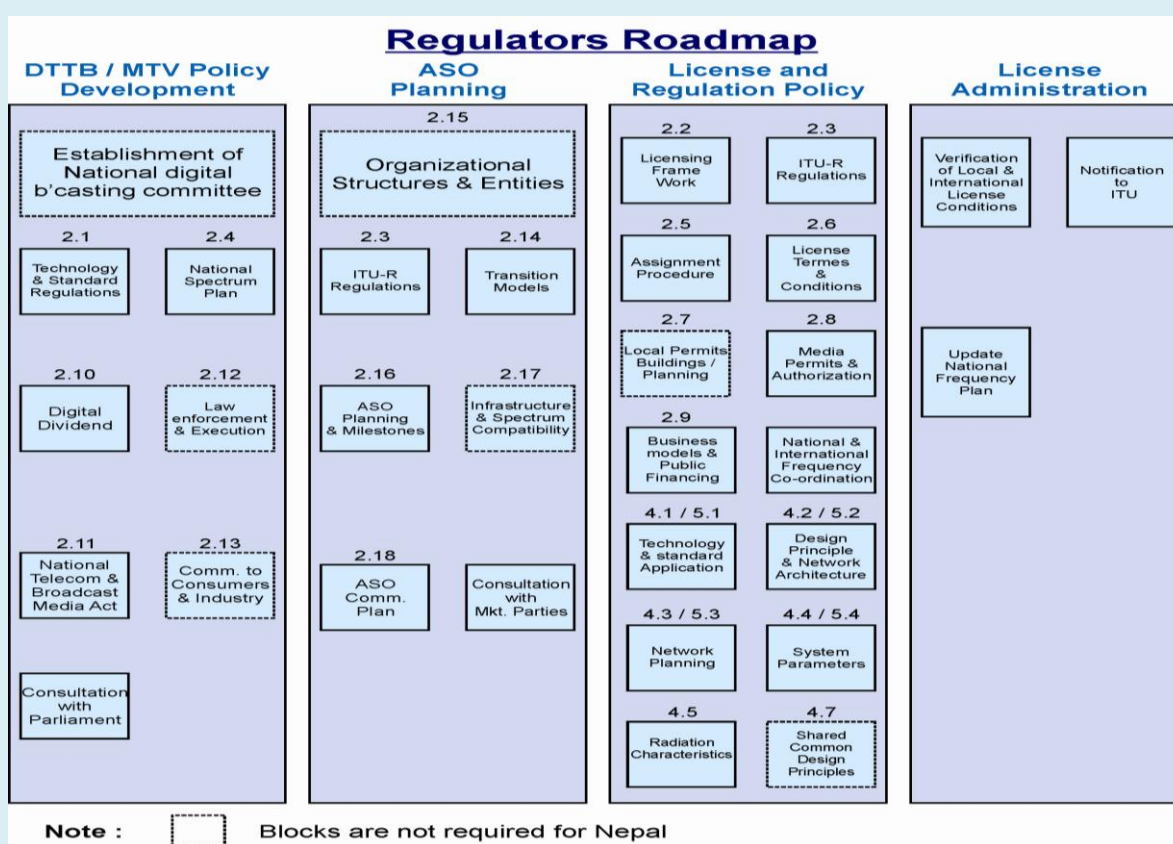

Note on building blocks of Figure 9

1. Establishment of National Digital Broadcastings Committee: the NRT constituted by the government will look after the activity
2. 2.3: Under ASO planning is being taken care of by 2.4 under functional layer on DTTB policy development.
3. 2.7: no regulatory framework in place at present, not an impediment as local clearance is made available without delay at present.
4. 2.12: Law enforcement and execution: revamping of the National Broadcasting Act 1993 is being undertaken but it is not considered as an impediment to the process of transition to digital television
5. 2.13: the function will be of interest to ASO Commission under 2.18
6. 2.17: Infrastructure compatibility is not considered a major issue as one multiplex only considered at present and no MTV is envisaged at present.

Spectrum issue is being taken care of by NSP

7. 4.7: At present one multiplex only and no MTV to start with.

Source: Adapted from ITU Guidelines

Figure 9 represents a generic case. In Nepal though it has been decided that multiplex ownership will be placed under the regulator for the purpose of coordination and management of the multiplexer in accommodating broadcaster requirements, but for all practical purposes of implementation of the plan, NTV being the major broadcaster will be responsible. The NRT will effectively take on the responsibility

and act as a digital broadcasting committee. The four phases can be carried out sequentially but in practice however, the first three phases are often carried out partly in parallel.

Figure 10 gives the interrelation between four phases of the roadmap for the regulator.

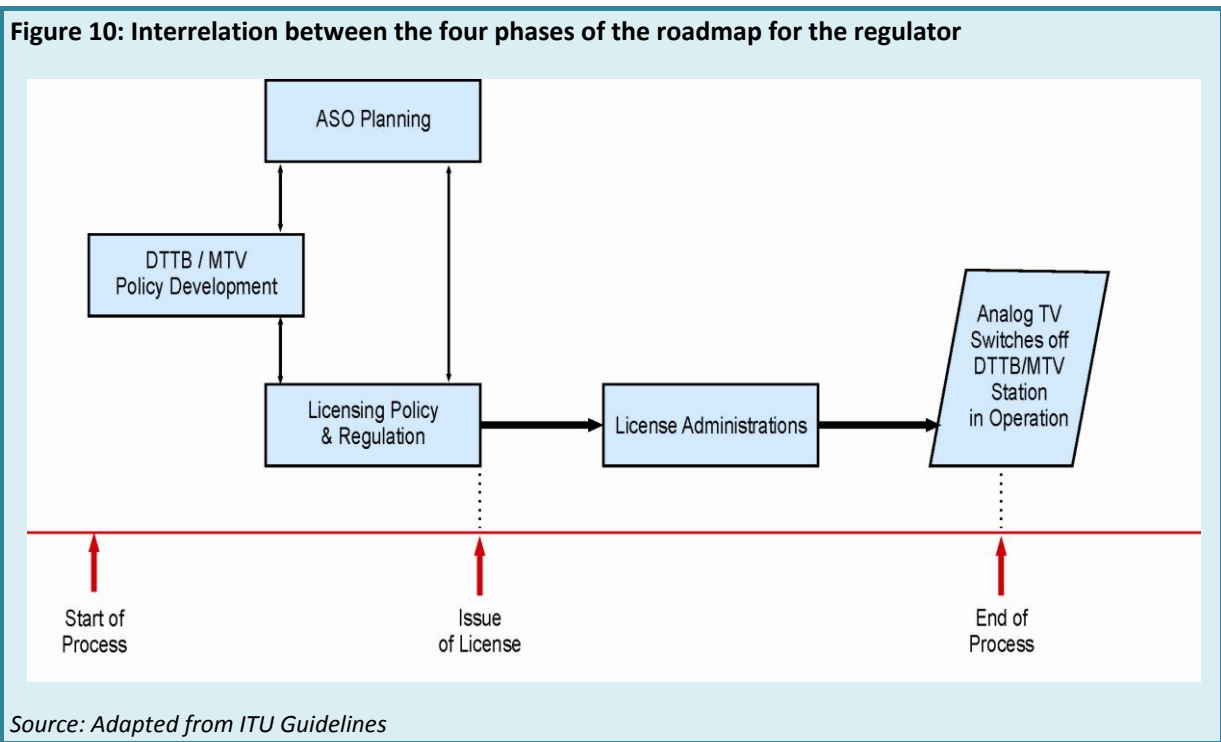

The process will start in 2011/12 and ends when all analogue TV is switched off and all DTTB stations are in operation without any restrictions that were necessary to protect analogue stations in simulcast mode. Since DSO and ASO has been spread over six years, the final analogue switch-off for Nepal will be December 2017.

Figure 11: Phase I of the regulator roadmap: DTTB/MTV policy development process

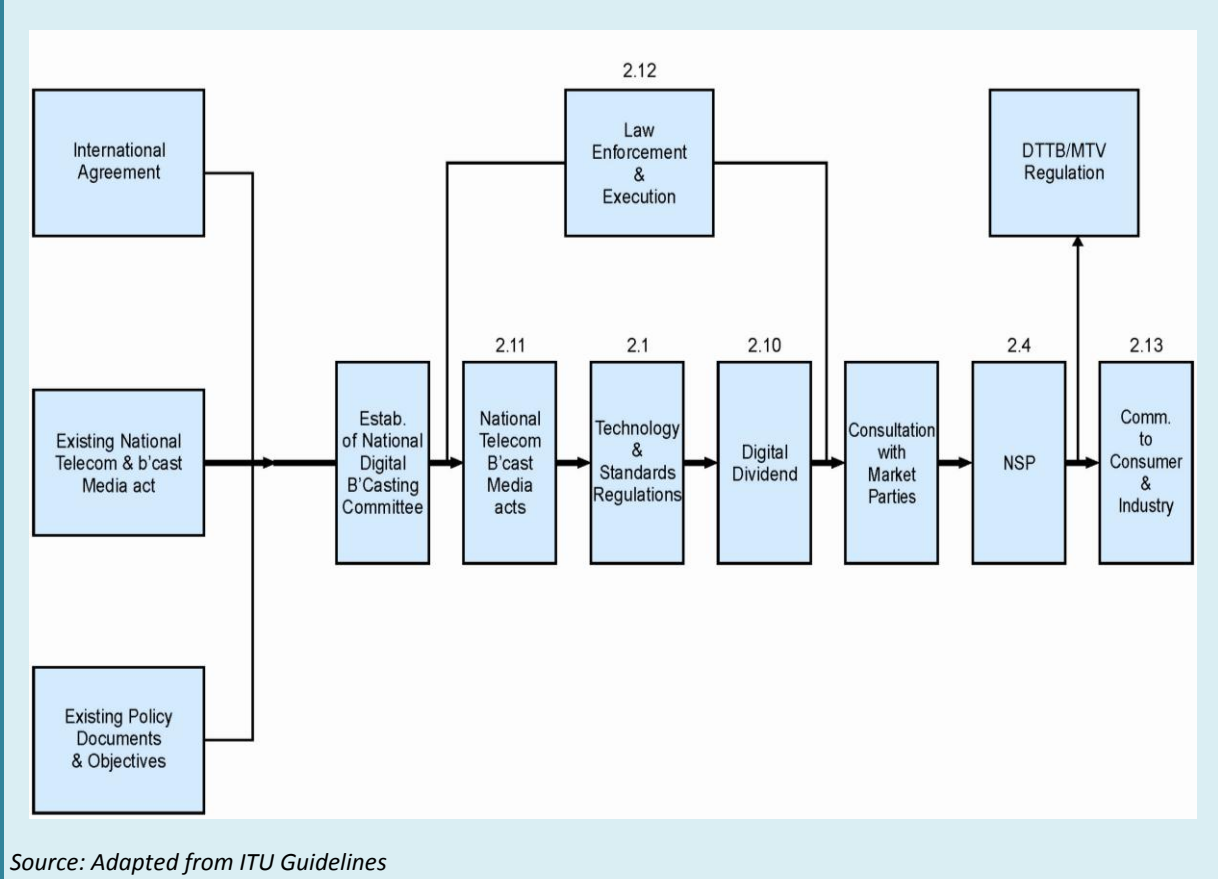

The input data to this phase involves international agreements and existing relevant legislation and policy documents for establishing DTTB/MTV policy. In Nepal the National Broadcasting Act, 1993 would need a revision and being an act of parliament has to be referred to the parliament. Similarly, changes to policy and regulation, which are administrative decisions, would have to be made by the Cabinet. Standards for receiver are to be set, requirements to be assessed, NSP to be updated, market has to be consulted, current and future requirement of spectrum has to be assessed and digital dividend worked out. Output of the phase will be the DTTB/MTV regulation.

Figure 12: Phase II of the roadmap for the regulator: analogue switch-off planning process

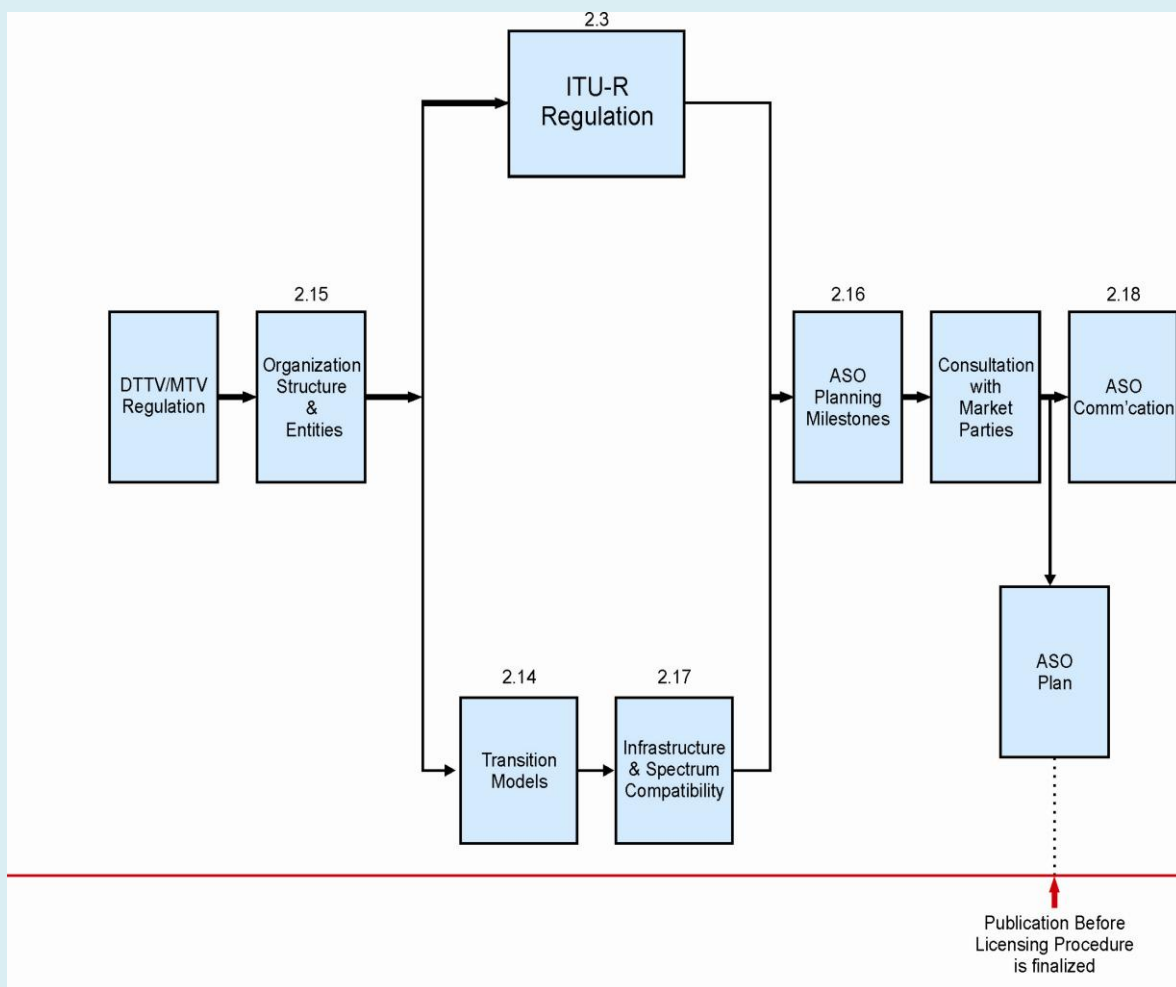

Source: Adapted from ITU Guidelines

The input to this phase is the DTTB/MTV regulations. An ASO commission is going to be set up in Nepal as the organisational structure for the ASO process. ASO planning has to be carried out and will be completed in phases in Nepal. Necessary budgetary provisions have to be made. The transition model for Nepal should be simulcast till viewers are equipped with STBs or IDTVs. This phase requires all players to communicate with each other. The ASO plan has to be communicated to all when ready. The output of this phase would be ASO plan.

Figure 13: Phase III: licensing policy and regulation process

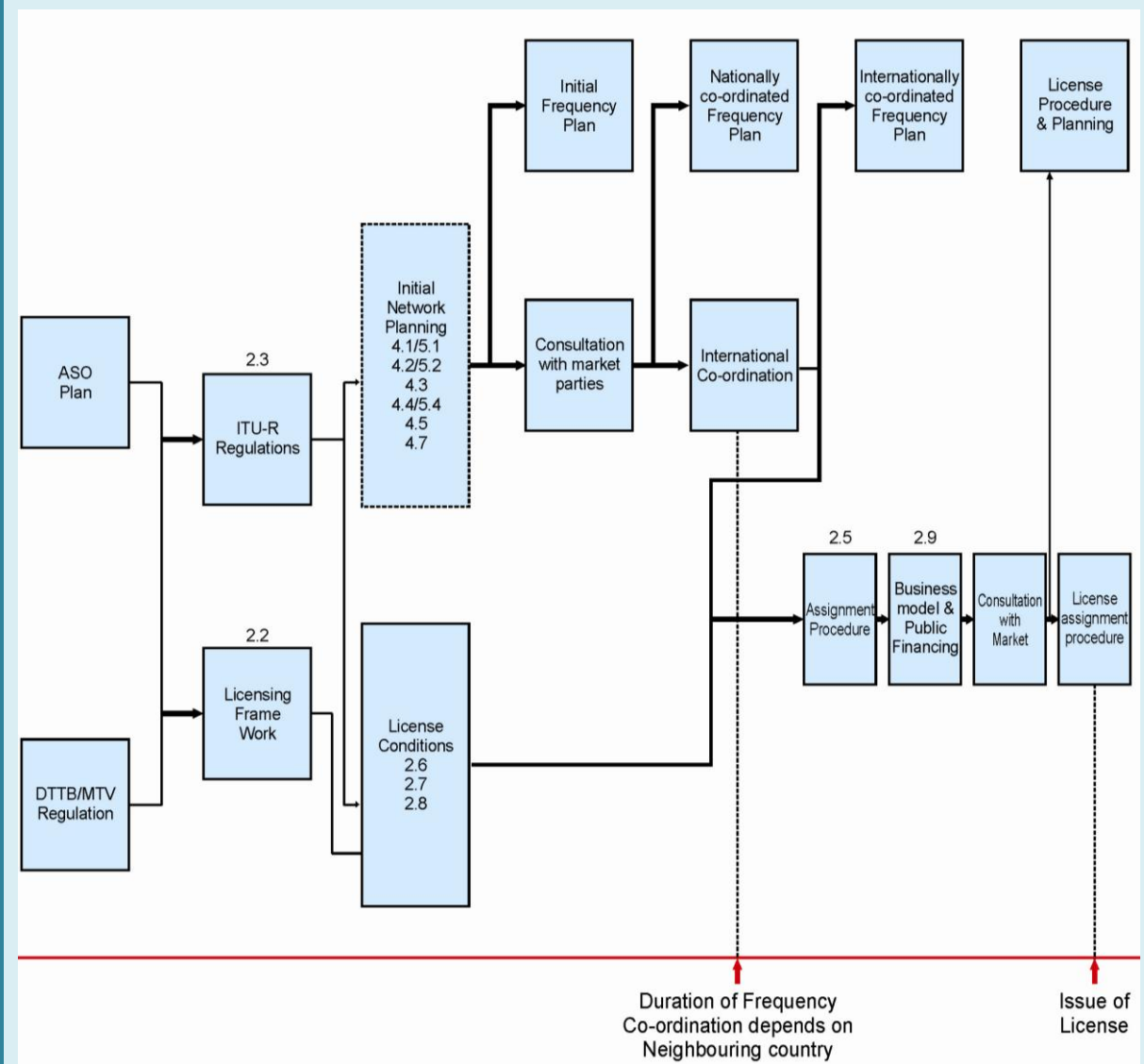

Source: Adapted from ITU Guidelines

The input to this phase of the roadmap for the regulator is the DTTB/MTV policy and the ASO plan. ITU-R is to be addressed for the identification of the frequency assignment or allotments available. Technical criteria for DTTB/MTV stations have to be established. Initial network planning concerning ITU Guideline functional building blocks 4.1 to 4.7 and 5.1 to 5.7 has to be carried out. Local and international coordination of initial frequency plan has to be completed. Frequency assignment procedure has to be finalised, the market has to be consulted and the license procedure and planning has to be finalised.

Figure 14: Phase IV of the roadmap for the regulator: licence administration process

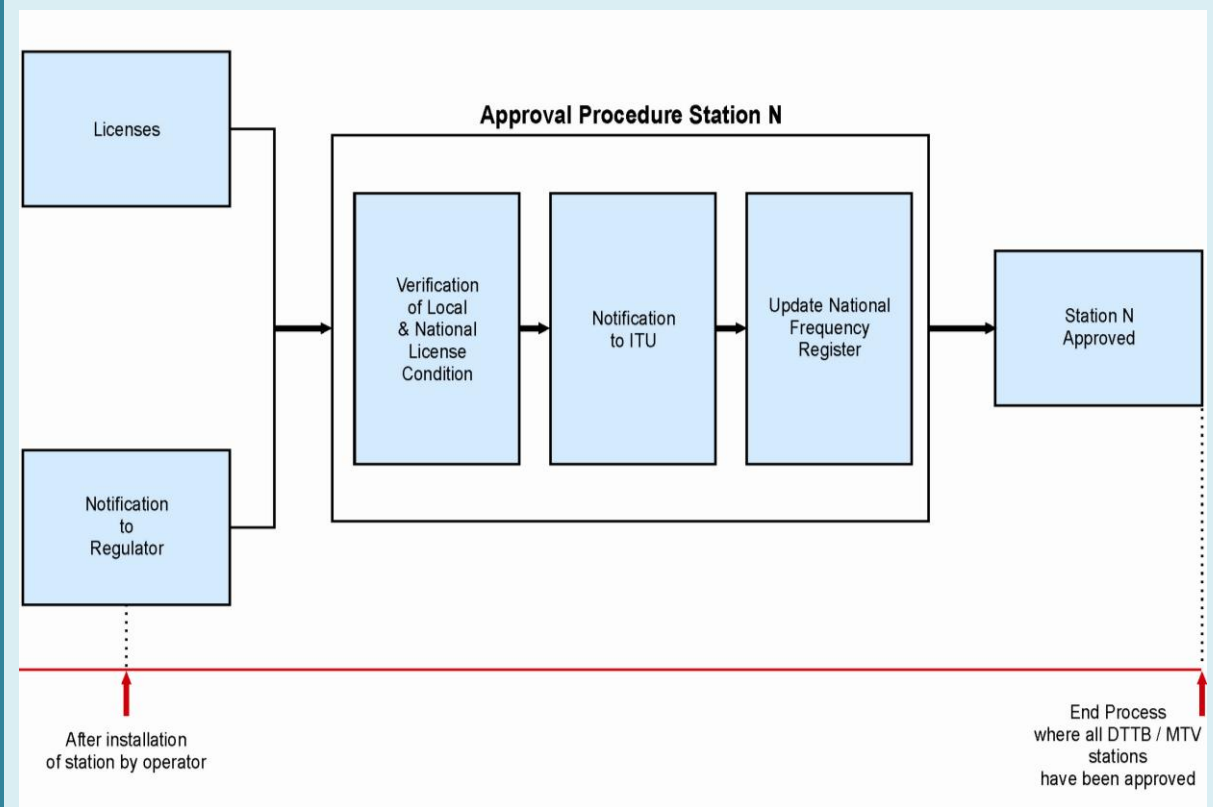

Source: Adapted from ITU Guidelines

In this phase the licence is verified, ITU is notified and the National Frequency Register is updated. Then the station is approved.

Figure 15: Overall roadmap for the regulator

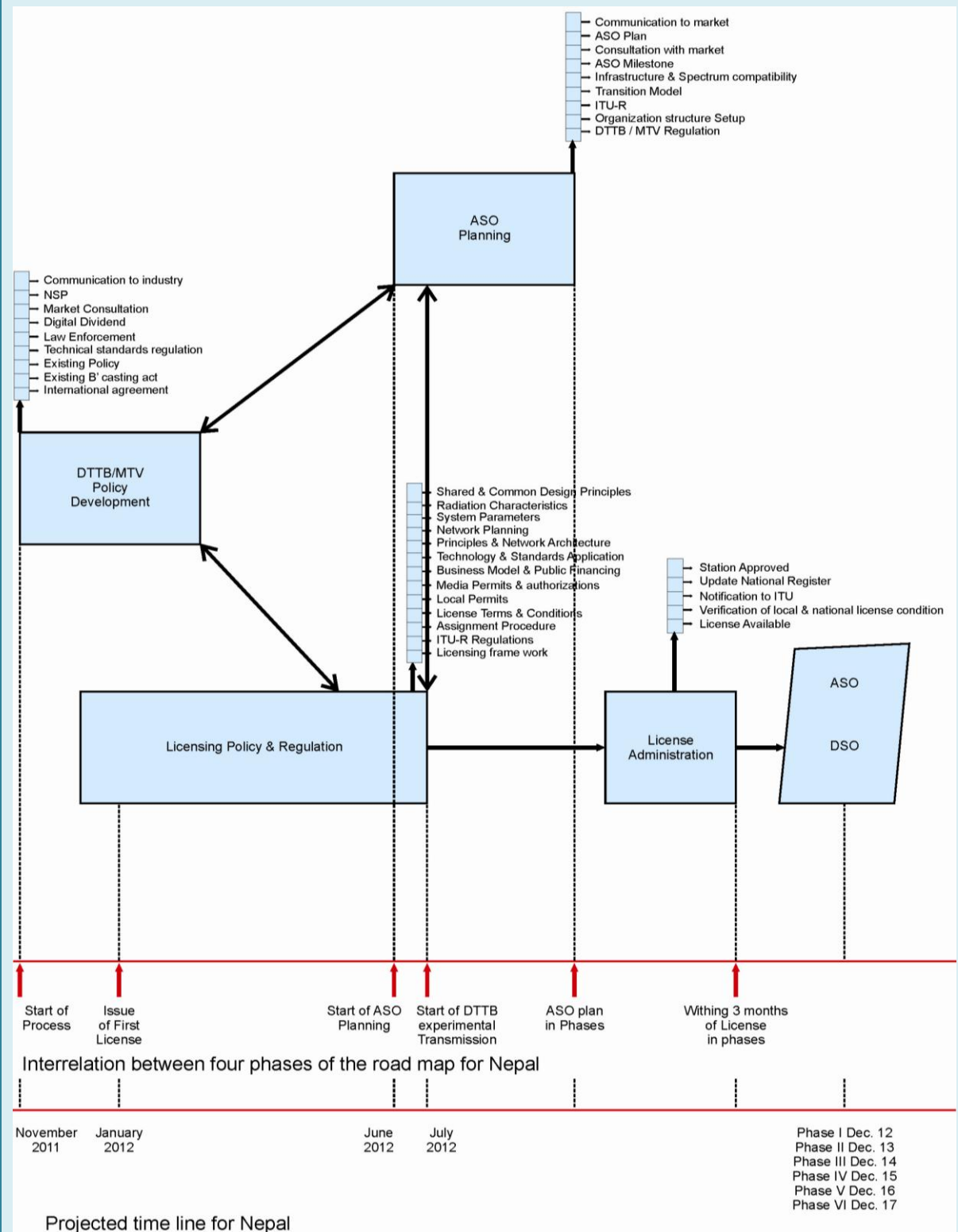

Source: Adapted from ITU Guidelines

3.4 Roadmap for the operator

Figure 16: Functional block connected to each of the four phases of network operator’s roadmap

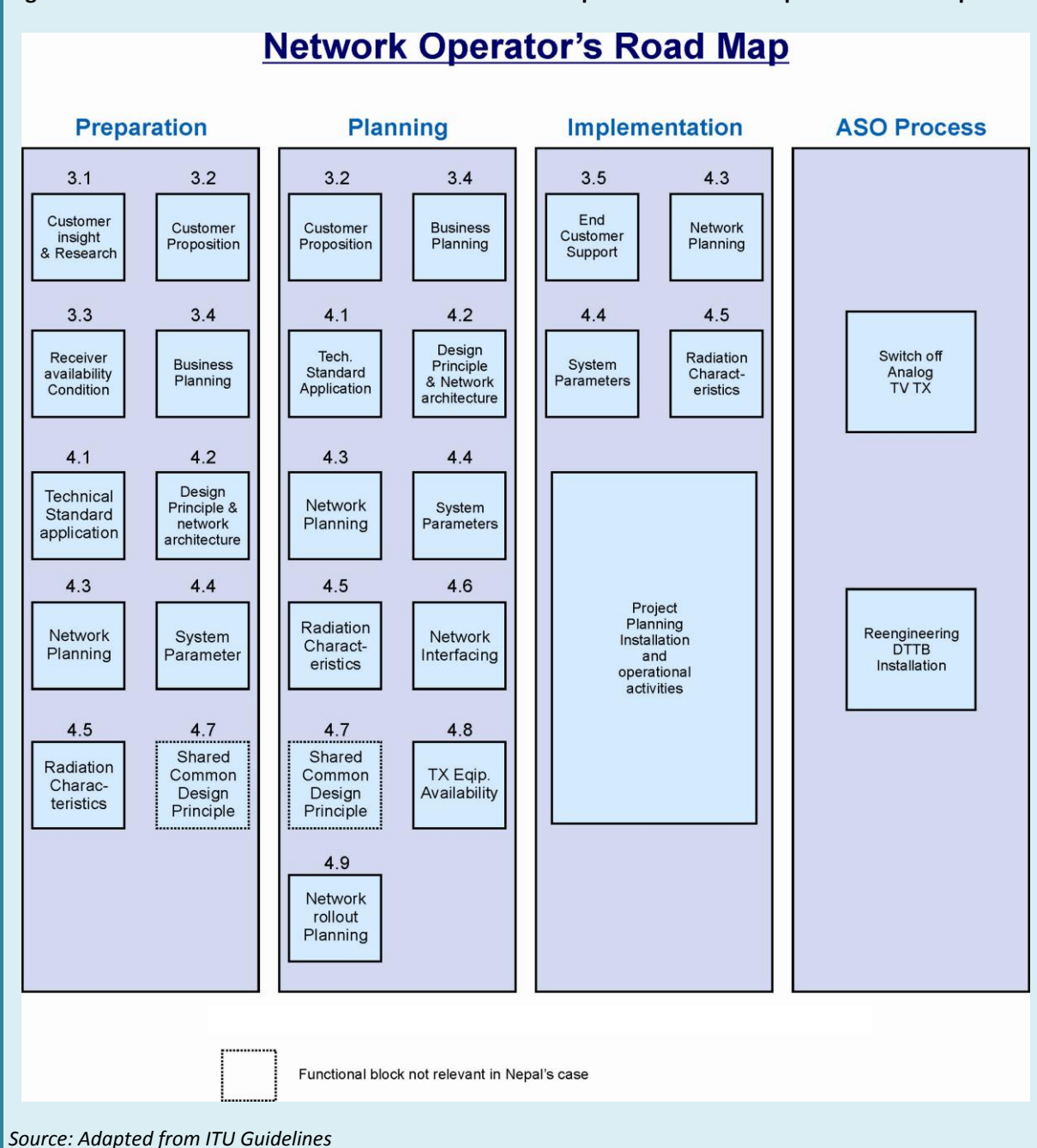

Source: Adapted from ITU Guidelines

The roadmap for the transition to DTTB by a network operator consists of four phases:

- 1) Preparation.
- 2) Planning.
- 3) Implementation.
- 4) Analogue switch-off.

The preparatory phase starts when the regulator is preparing the licence policy and regulation and the aim of the preparation is to apply for a DTTB licence. The planning phase starts with the date of issue of

the licence and ends with adoption of the network implementation plan. The implementation phase is complete when the DTTB transmitter is operational and the ASO plan gives the time schedule when the analogue transmitters are switched off. The functional blocks of each phase have been identified in Figure 17. In this case one DTTB operator acting as multiplex operator, service provider and content distributor has been assumed as is the case of NTV in Nepal.

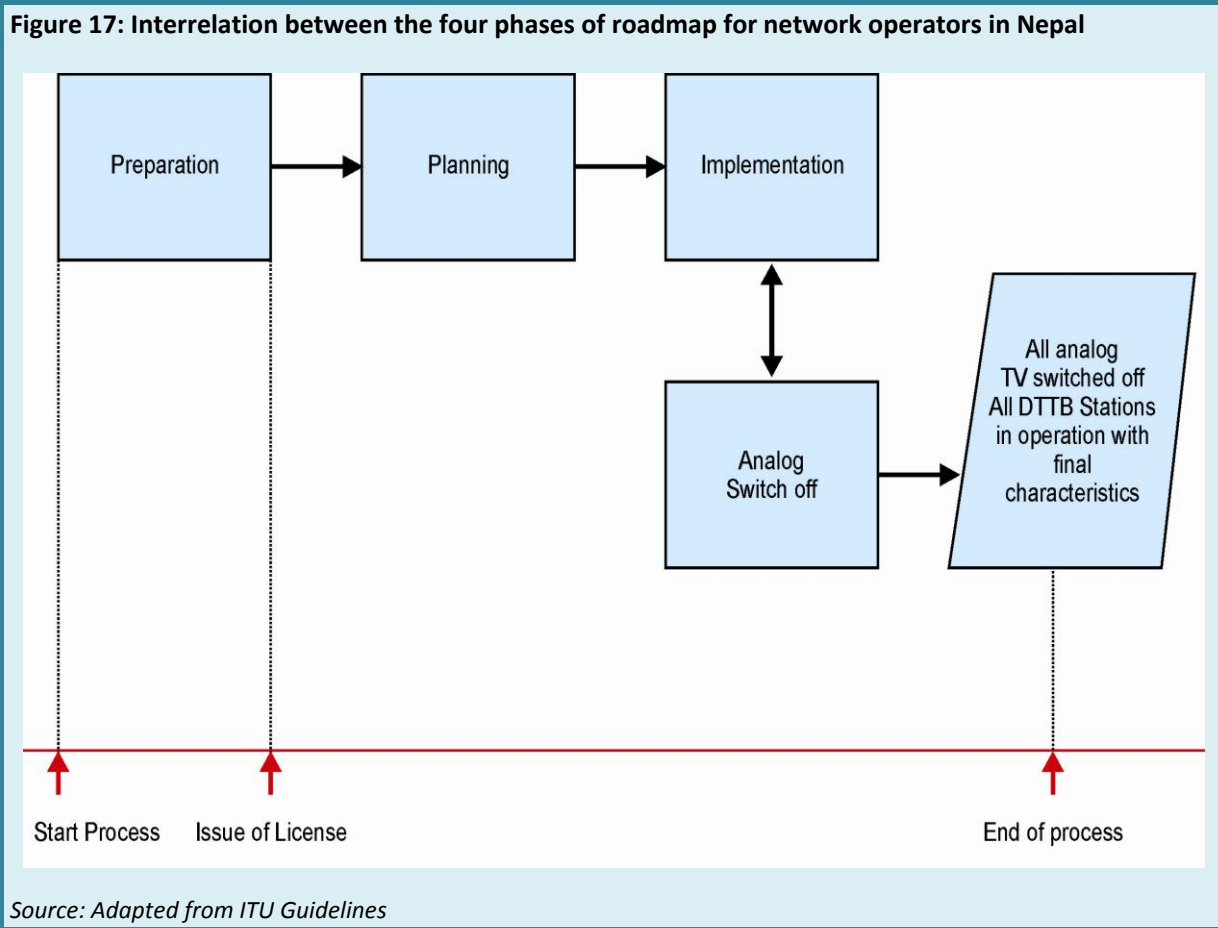
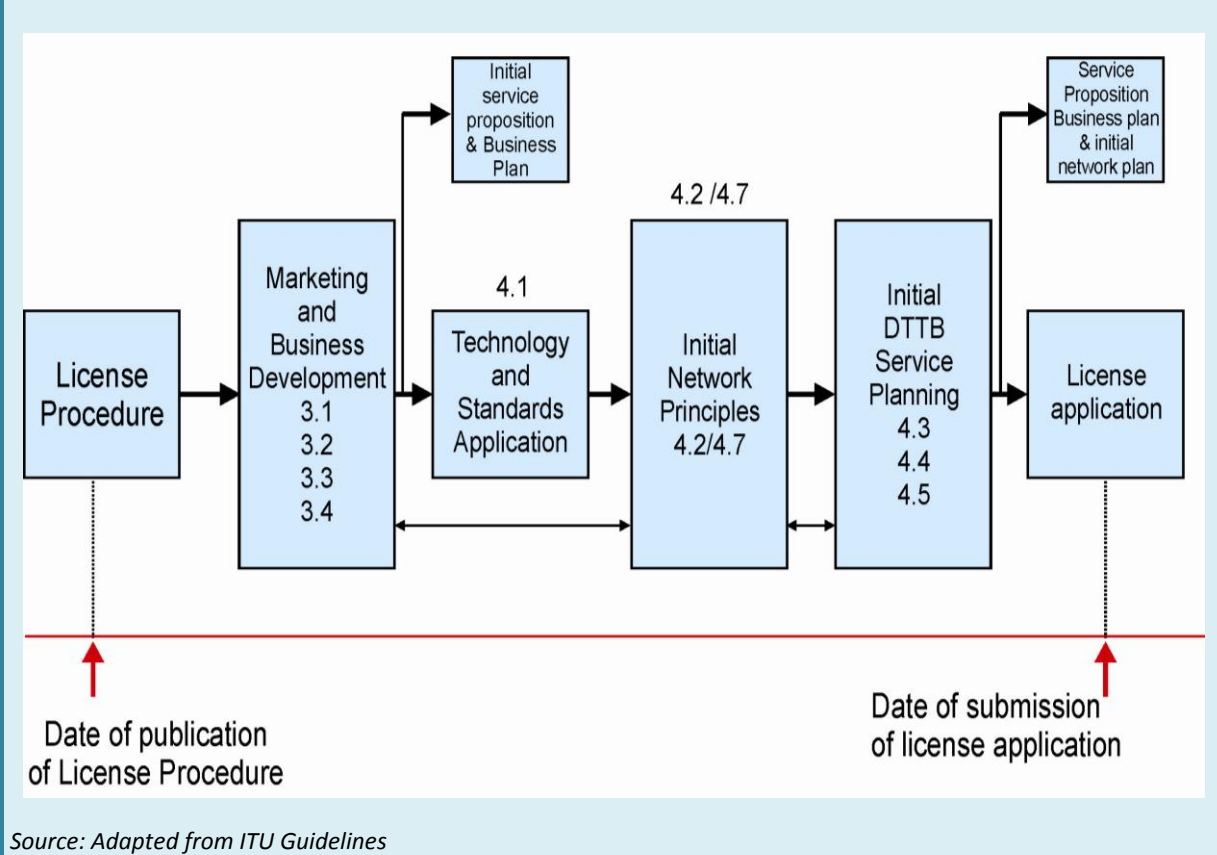

Figure 18: Phase I of roadmap for the operator: Preparations



Source: Adapted from ITU Guidelines

The preparation normally starts when the licence procedure has been published. In this phase the network operator will address market and business development by responding to key points of ITU Guideline functional blocks 3.1, 3.2, 3.3, and 3.4. Then the operator will address technology and standards application in 4.1 and will carry out initial DTTB service planning (4.3, 4.4, 4.5) by defining network principles in 4.2 and 4.7. In the preparatory phase not all station characteristics are specified but only those taken to verify the business plan and to have sufficient data to apply for a licence which is the output of this phase.

Figure 19: Phase II of the roadmap for the operator: Planning

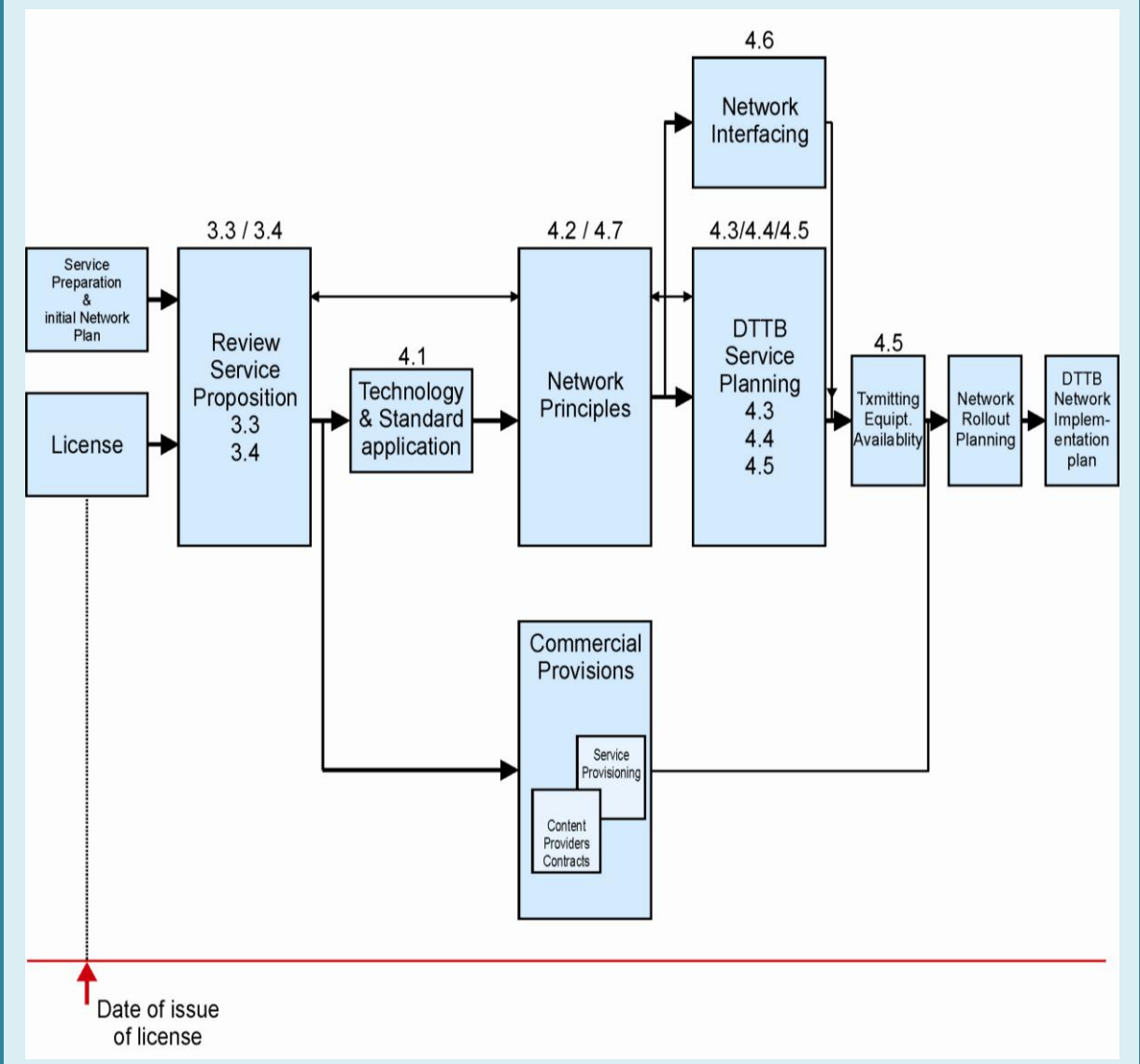

Source: Adapted from ITU Guidelines

This phase starts when the licence has been issued. The input to this phase is the licence and the initial service plan, and the output is the DTTB network implementation plan. Depending on the licence conditions, the customer proposition and the network roll-out planning are necessary for the final DTTB network implementation plan.

Figure 20: Phase III of the roadmap for the operator: Implementation

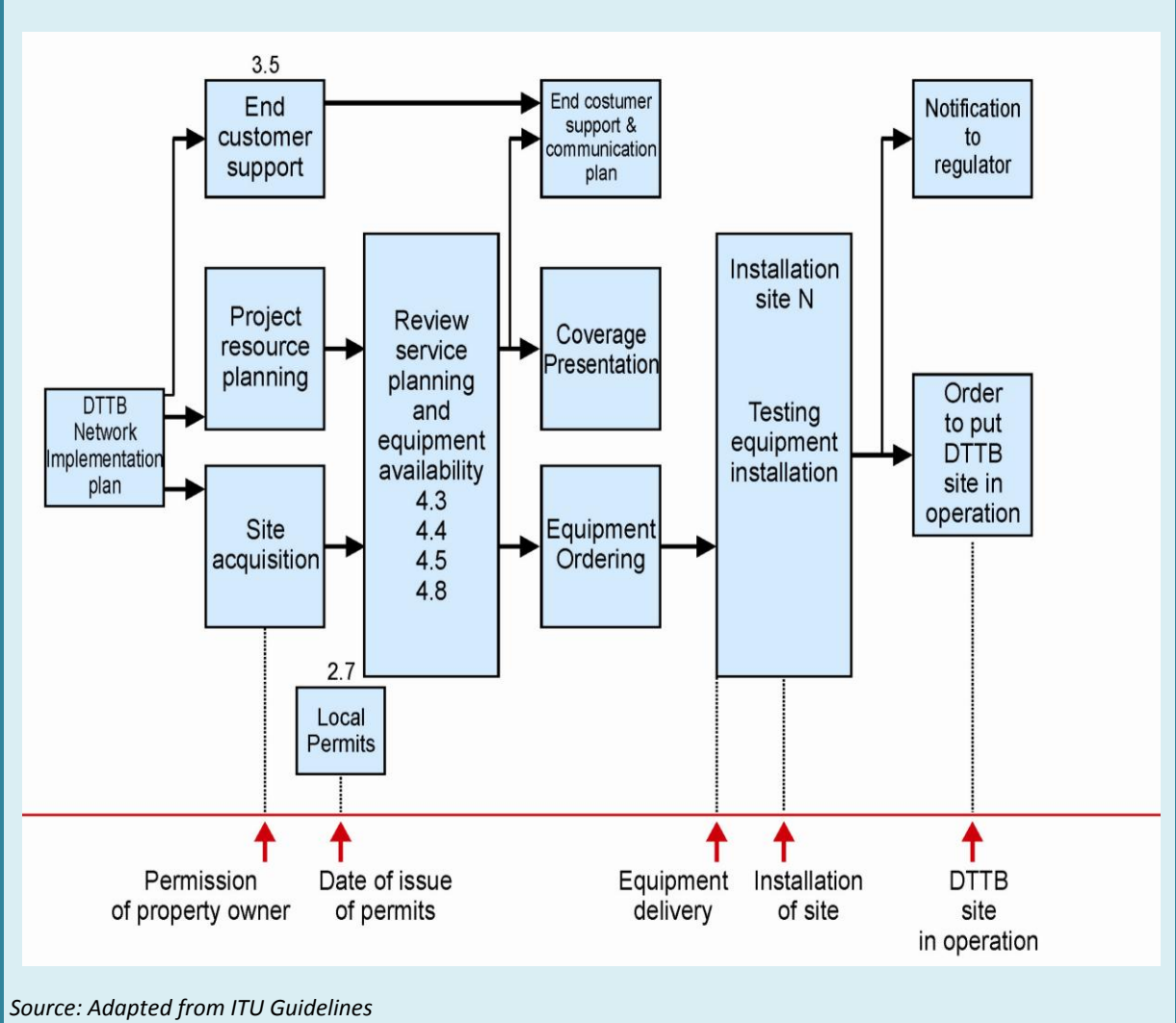

Source: Adapted from ITU Guidelines

The implementation phase of the DTTB network starts when the network implementation plan as the output of phase II is available. Site acquisition and project resource planning start, and local building/permits are obtained. Further modifications to the network implementation plan may be called for and carried out here. Equipment is ordered and viewers are notified. Installation and commissioning is carried out on arrival of the equipment. The regulator is notified and the DTTB site is put into operation.

Figure 21: Phase IV of roadmap for the operator: Analogue switch-off

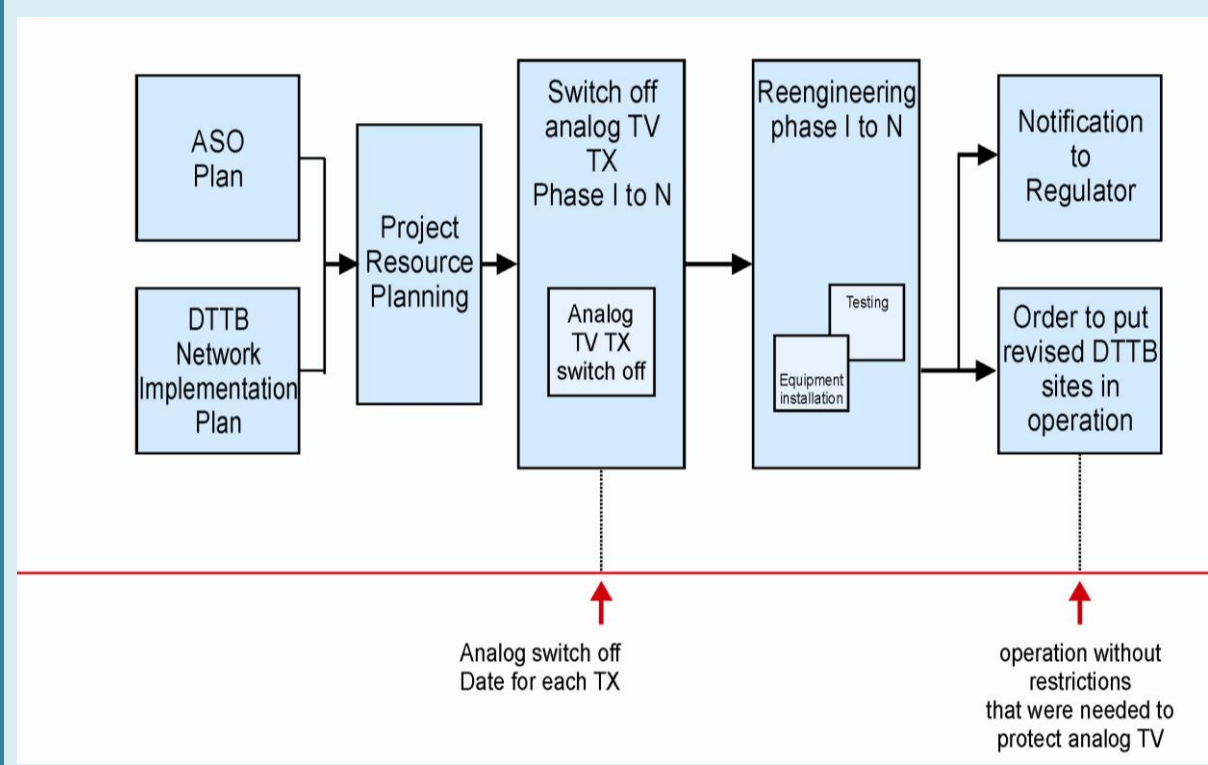

Source: Adapted from ITU Guidelines

The input to this phase is the ASO plan and DTTB implementation plan. Reengineering of analogue equipment is carried out and superfluous equipment is removed. The DTTB transmitter is installed and adjustment to radiation characteristics made and restrictions to analogue transmitters removed. Then analogue transmitter is switched off and the regulator is notified.

Figure 22: Overall roadmap for the operator

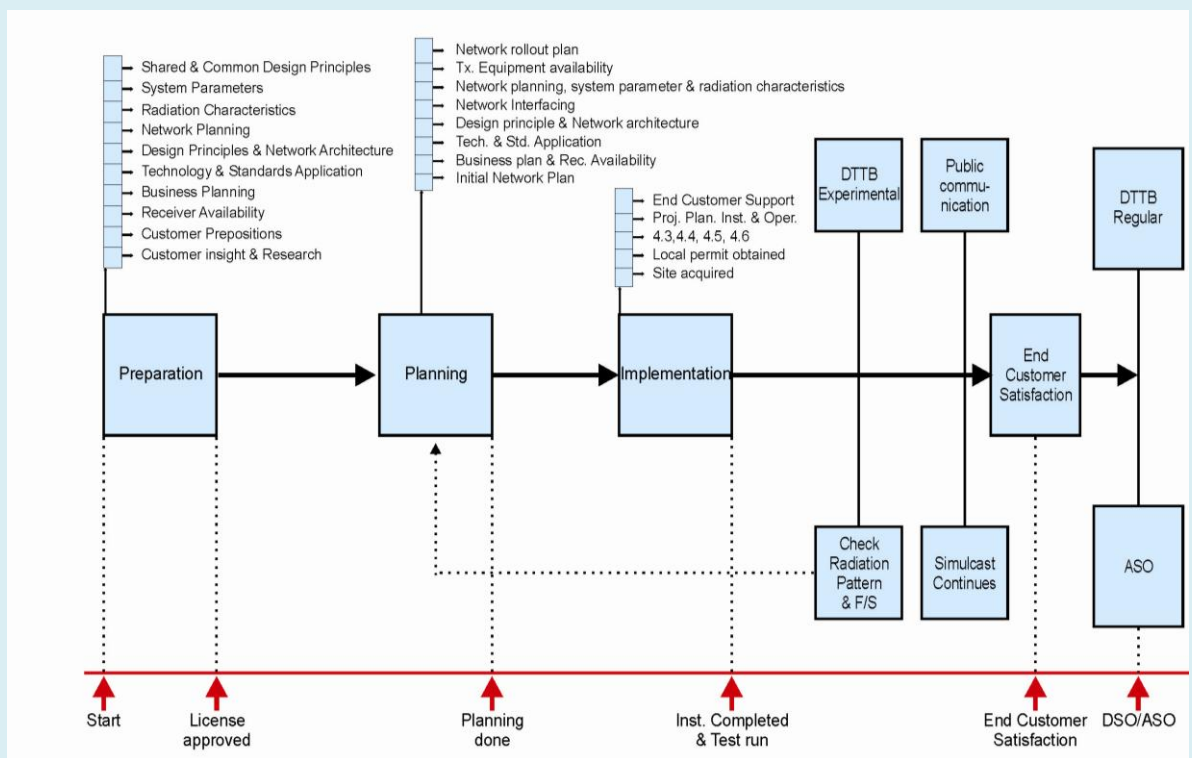

Interrelation between four phases of road map for network operator

Phasing

1st	Nov. 2011	Jan. 2012	March 2012	July 2012	Dec. 2012	Dec. 2012
2nd	July 2012	Jan. 2013	March 2013	July 2013	Dec. 2013	Dec. 2013
3rd	Jan. 2014	March 2014	May 2014	July 2014	Dec. 2014	Dec. 2014
4th	Jan. 2015	March 2015	May 2015	July 2015	Dec. 2015	Dec. 2015
5th	Jan. 2016	March 2016	May 2016	July 2016	Dec. 2016	Dec. 2016
6th	Jan. 2017	March 2017	May 2017	July 2017	Dec. 2017	Dec. 2017

Proposed Date line for DSO/ASO for Nepal

Source: Adapted from ITU Guidelines

Figure 23: Overall roadmap for transition from analogue to digital TV transmission in Nepal

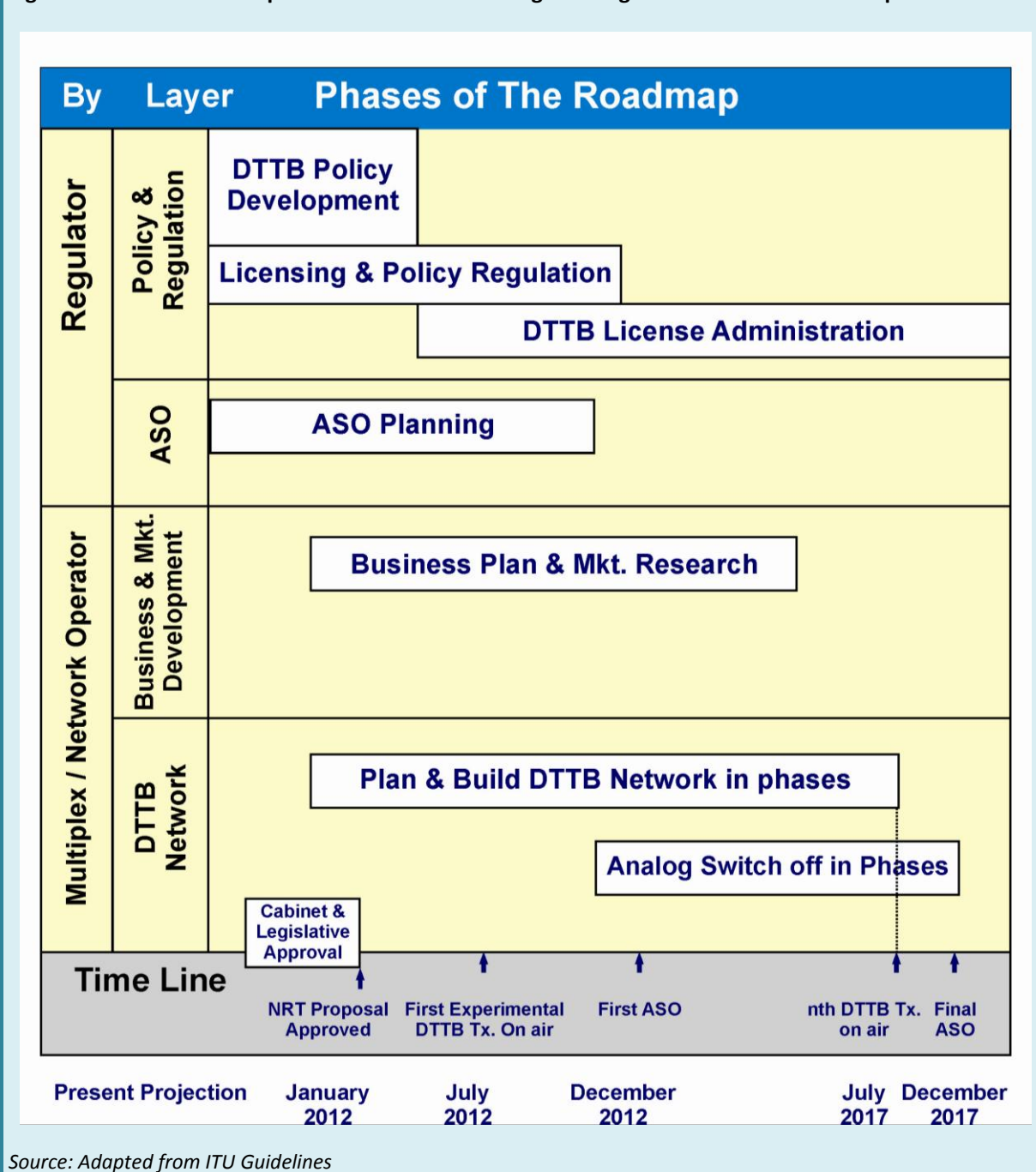

4 Consideration on the ten most critical topics

4.1 Financial resources

The funds required are basically for DSO and ASO strategy.

Funds required for the DSO

- a) Procurement of transmitter and other equipment including the head-end (as equipment available to NTV is very old).

- b) Cable and antenna system and in a few cases the tower. Since NTV will move to UHF, they will need new cable and antenna systems.
- c) Building modification and procurement of portacabins (as in most places there is no extra space to install a DTTB transmitter). Also augmentation of power supply system and the cooling system in all cases would be required.
- d) Training of staff (and may be one experimental set-up) for gathering information and checking coverage.
- e) Private operators may also request support at a later date.

Funds required for ASO implementation

- a) To provide viewers with STBs or cash equivalent so that they are not deprived of reception of TV signal.
- b) To suppliers/importers/distributors, duty concessions for importing STBs/IDTVs etc.
- c) To provide funds for setting up of ASO office to drive implementation of ASO policy.
- d) To provide antennas to viewers in most cases and to set up customer relationship management for initial periods to address customer grievances.
- e) Duty concessions to the broadcasters/network operators for the importation of capital equipment.

Infrastructure cost estimates

The ITU Guidelines provide a capital and operating expenditure budget example priced in Euros which may serve as a rough guide for Nepal. However, there are several differences in the scope such as: the number of transmitters, power levels, and the number of required multiplex. The correct method to estimate costs is to call for tenders to find out the prices for the required equipment. But by interpolating the example, we may get a rough cost estimate for Nepal as follows:

Details of items for DTTB (1 mux)	Capex in NPR	Opex in NPR (millions)
Head-end	65 m	125 m
Adjustment of existing network	25 m	5 m
Distribution	30 m	25 m
Maintenance		55 m
Transmitter and combiner	150 m	
Ant	30 m	
Total	300 m	210 m

The above estimates are indicative only and need to be recalculated on the basis of market feedback.

4.2 Strong leadership

Change is normally resisted. Complexities are too numerous for a smooth change over. Hard decisions are called for. Continuous monitoring and remedial action is a must. Government needs to ensure strong leadership in the ASO commission and in the regulatory framework.

A strong ASO body (commission) is absolutely essential in Nepal as individual players are too busy with their daily work and such a body would focus attention on monitoring progress and pursuing each activity to its logical conclusion. Since it would be represented by all sectors, problems related to each sector would be handled in a well-informed manner. Also the much needed communication with industry, viewers and other players could be established easily resulting in a quick and efficient ASO.

4.3 Regulatory changes

- a) Change licensing procedure.
- b) Change licensing conditions.
- c) Decide ownership of multiplex.
- d) Frame rules for multiplex sharing.
- e) Tighten law enforcement and regulation.
- f) Set up wireless monitoring under the technical wing of the regulator.
- g) Set up a mechanism for speedy clearance/approval of local permits.

4.4 National frequency plan

- a) A DTTB frequency plan for the whole of Nepal with 13 UHF channels, taking note of neighbouring country assignments, needs to be drawn up.
- b) Incorporate the frequency plan in the NSP.
- c) Publicise the NSP and revise it, if necessary with public feedback.
- d) Try to get more frequencies in Band IV for future expansions.

4.5 Best content

- 1) Arrange with content distributor regarding availability of best content in the platform.
- 2) Have media permits and content regulation laws revised to accommodate DTTB requirements.
- 3) Broadcasters/operators to be encouraged to have studio equipment changed to digital so that the whole chain is digital.

4.6 Technical standards based on coverage and reception quality to suit public requirements

- a) Having decided DVBT2/DVB-H standard, further parameters may be chosen for the transmitter to benefit the majority of viewers. NRT has been provided with required technical inputs for taking appropriate decisions. Increased number of channels provides an alternative to cable TV and in FTA mode saves a few dollars of customer's money each month. This is important in the context of the low per capita income in Nepal and in the interest of viewers.
- b) Keep a reserve in transmitter power to ensure better coverage quality.
- c) The unique selling point of DTTB is going to be portability and HDTV but it may take some time to come to that stage in Nepal. However planning should take note of that.

4.7 Digital dividend

Analogue TV in Nepal is now using eight channels in Band III and five UHF Band IV channels. For DTTB, another eight channels in UHF Band IV have been earmarked in the national plan to be used initially for the simulcast period and it has been envisaged that DTTB/MTV operations will be in UHF band to take advantage of the 8 MHz bandwidth. The VHF Band III frequencies as freed on implementation of ASO should be auctioned to provide necessary funds for the DSO and ASO strategy.

4.8 Revision of National Broadcasting Act, 1993

The National Broadcasting Act, 1993 needs to be revised to incorporate changes in the licensing framework, terms and conditions of a licence, enforcement and execution of licence conditions, incorporate multiplex ownership and sharing conditions, and to make provisions for content regulation. Empowerment through legislation will enable the regulator to have better spectrum management. The present act has loopholes which are being exploited for spectrum hoarding and necessary steps should be taken to stop that. The technical examination of licence applications and the issue of the administrative order issuing the licence should rest with one entity.

4.9 Develop suitable business plan

For the public service broadcaster, a free to air mode is considered suitable. The state owned broadcaster NTV is already earning 85 per cent of its operating cost from advertisement revenue. In DTTB mode with better picture quality and more channels, the advertisement revenue is likely to go up. Effort is required to bring private operators to the platform which improves viewership and brings additional income from platform charges.

The commercial broadcasters could have a mix of FTA and CA based offerings which are expected to enhance their earnings. Subscription based earning can be further improved and should be tried. Some private broadcasters are already managing with advertisement and subscription revenue in analogue mode with one programme channel. Hence, it is expected that either by joining a platform, thereby reducing their recurring cost, or owning multiplex (if allowed), which enables them to have a multichannel operation, the existing business model would fund the operation and there would be enough scope for improvement.

4.10 Staff training

Training of staff at all levels is an essential component of the project. Theoretical and practical knowledge of the new technology is required. This can be acquired through seminars, training courses, workshops, practical demos so that the skill of existing staff is upgraded and they are in a position to discharge their responsibilities. A core group of senior engineers are also required to be trained in aspects of project and network planning, frequency planning, and tests and measurements.

5 Recommendations

No more licences for analogue TV broadcasting should be issued and notices to existing broadcasters about government plans to switch over indicating the ASO target should be sent out.

Resources are required to be provided for DSO and ASO objectives. Since the whole process has been spread over a period of five years, mobilisation of resources for each year lessens the burden. Selling of the Band III frequency by auction may bring sufficient relief.

Viewers, retailers, broadcaster, industries, trade associations/chambers etc. are to be informed, educated about the advantages etc. in advance. Establishing proper and timely communication is essential.

STBs, IDTVs, antenna, etc. have to be provided to viewers. Bulk procurement may provide best prices. Industry could be encouraged to go for development or kit (ckd/skd) assemblies to reduce cost of STB further or using duty concessions. Viewers up to a certain income level in rural areas/towns may be provided with financial support for procurement of STBs/IDTVs to reduce the financial burden.

Grievance redress mechanism and help to customers must be provided. The fact that help will be forthcoming in case of difficulties would encourage customers to switch over. Retailers should have their technicians properly trained to respond to customer enquiries.

Training courses must be created by inviting experts from abroad, if required. Engineers/technicians from public service broadcasters and private broadcasters should be trained on both theoretical and practical aspects (once the pilot project has been completed). A few core engineers may be required to train abroad ahead of activities to draft equipment specifications and for the testing and commissioning of transmitter and associated equipment.

One full set of test and measuring equipment is to be procured and kept at Kathmandu to be used elsewhere in the network as and when required.

For frequency planning of the network, if in country expertise is not available, expert help from abroad may be sought to develop the best coverage planning with the least interference.

Regulatory changes as suggested in action points may be incorporated. The broadcasting act has to be thoroughly reviewed. The regulator must be given monitoring, and search and seizure powers to deal with any violation of the broadcasting act.

Content is king in television and attractive content different from the normal menu has to be created to make the platform different and unique from others to become successful.

Since Nepal is now going to have a federal government, it would be necessary to respond to the aspirations of federal unit/zones with the following actions:

- a) to meet future requirements of TV spectrum for transmitters in the federal unit/zones in future, try to have more UHF channels for TV broadcasting; and
- b) to have the necessary monitoring/measuring facilities at the federal units/zones, to make provision for procurement of hardware which are absolutely essential.

Annex I

www.lawcommission.gov.np

The National Broadcasting Act, 1993

Date of Authentication and Publication

2050.2.27.4 (9 June 1993)

Amendments,

- | | | |
|----|--|------------------------------|
| 1. | Communication Related Some Nepal Acts
(Amendment) Act, 2057 (2001) | 2057.10.18
(31 Jan. 2001) |
| 2. | Provisions of Some Nepal Acts Revival Act,
2063 (2006) | 2063.4.23
(8 Aug. 2006) |
| 3. | Republic Strengthening and Some Nepal
Laws Amendment Act, 2066 (2010) | 2066-10-7
(21 Jan. 2010) |

Act Number 6 of the Year 2049 (1993)

An Act made to provide for national broadcasting

Preamble: Whereas, in order to protect and promote the freedom of expression and the right to be informed guaranteed to the people by the ¹Constitution, and to raise public awareness also through ²national language by creating an environment of equality, mutual good faith, and harmony amongst all the tribes, languages, classes, regions and religious

¹ Amended by the Republic Strengthening and Some Nepal Laws Amendment Act, 2066

² Amended by the Republic Strengthening and Some Nepal Laws Amendment Act, 2066

www.lawcommission.gov.np

denominations by imparting economic, social and cultural activities of the country to the people through the broadcasting system,

Whereas, it is expedient to make legal provisions on the broadcasting, without any obstruction, of the flow of information in order that the general public get informed about impartial as well as authentic news and information taking place at the national and international level, by making the broadcasting media reliable, effective and strong, with the use of modern technology available in the field of information and communications;

Now, therefore, be it enacted by Parliament in the Twenty-Second year of the reign of His Majesty the King Birendra Bir Bikram Shah Dev.

1. **Short title and commencement:** (1) This Act may be called as the "National Broadcasting Act, 2049 (1993)"
(2) This Act shall come into immediately.
2. Definitions : Unless the subject or the context otherwise requires, in this Act, -
 - (a) "Broadcasting " means the radio communication service to be so sent through signal, sound, image, picture or similar other way that the general public may get information.
 - (b) "Programme" means any kind of Programme to be broadcast through audio or audio-visual means.
 - (c) "Frequency modulation broadcasting system" means a broadcasting made for the radio ³or television technology, by

³ Revived by the Provisions of Some Nepal Acts Revival Act, 2063

a broadcasting institution through the prescribed channel by using the frequency modulation broadcasting system.

- (d) "License" means the broadcasting license to be issued pursuant to Section 6 for broadcasting any Programme or the license to be issued for broadcasting by establishing the frequency modulation broadcasting system.
- (e) "Broadcasting institution" means a person or body corporate having obtained the license to broadcast Programmes under this Act.
- (f) "Satellite" means the satellite placed in the space in order to obtain various broadcasting materials (signals) or send them elsewhere.
- (g) "Cable" means the technology by which broadcasting materials (signals) are sent to various customers, members or consumers by wire from any certain broadcasting station.
- (h) "Earth station" means a station to be established in the earth surface in order to exchange broadcasting Programmes through satellite.
- (i) "Broadcaster" means a person reading out a Programme to be broadcasted by a broadcasting institution, and this term also includes a person who composes and edits such Programme.
- (j) "Prescribed" or "as prescribed" means prescribed or as prescribed in the Rules framed under this Act.

3. **Supervision and operation of Programmes relating to broadcasting**: Government of Nepal shall have the powers to

formulate policies on supervision and operation of Programmes relating to broadcasting within ⁴..... Nepal.

4. **Prohibition on broadcasting without license**: No one shall broadcast any Programme without obtaining the license pursuant to this Act.
5. **Application for license**: Any person or body corporate who intends to broadcast any Programme by way of satellite, cable or other means of communication or to broadcast any educational (didactic), entertaining and informative Programmes by establishing the frequency modulation broadcasting system in any place within ⁵..... Nepal shall submit to Government of Nepal an application in such format and accompanied by such fee as prescribed.
6. **Issuance of license**: Upon receipt of an application as referred to in Section 5, Government of Nepal may, holding necessary inquiry into the application, issue the license, in the prescribed format, for broadcasting a Programme, subject to observance of the prescribed terms.
7. **Powers to prevent broadcasting**: Taking into account of the nation and national interest, Government of Nepal may, by a notification published in the Nepal Gazette, prevent any Programme pertaining to any particular subject, event or area from being broadcast by a broadcasting institution, for a period not exceeding six months at a time.
8. **Power to cancel license of broadcasting institution**: (1) If, any broadcasting institution broadcasts any Programme in contravention

⁴ Omitted by the Republic Strengthening and Some Nepal Laws Amendment Act, 2066

⁵ Omitted by the Republic Strengthening and Some Nepal Laws Amendment Act, 2066

www.lawcommission.gov.np

of this Act or the Rules framed hereunder, Government of Nepal may cancel the license obtained by such broadcasting institution.

(2) Prior to cancellation of the license under Sub-section (1), Government of Nepal shall give a reasonable opportunity to such broadcasting institution to defend itself.

9. **Special provisions on establishment of earth station:** (1) Any person or corporate body, ⁶or a native and foreign person or corporate body in joint investment, who intends to broadcast any Programme by establishing the earth station relating to satellite and cable television, has to submit an application to Government of Nepal for permission.

(2) Upon receipt of an application referred to in sub-section (1), Government of Nepal may, if, following necessary inquiry into that application, it deems reasonable to give permission to the applicant to broadcast any Programme by establishing the earth station relating to satellite and cable television, issue permission, as prescribed, to broadcast the prescribed Programmes, subject to observance of the prescribed terms.

(3) Other provisions on the establishment of the earth station and broadcasting shall be as prescribed.

10. **Broadcasting and distribution fee:** If a broadcasting institution intends to distribute and operate any Programme, the fees to be paid to Government of Nepal or the prescribed organization and the fees to be collected from the persons or bodies using such Programme shall be as prescribed.

⁶ Revived by the Provisions of Some Nepal Acts Revival Act, 2063

11. **Production and broadcasting of Programmes:** While producing and broadcasting any Programme, a broadcasting institution has to give priority to the following matters:-
- (a) Development-oriented Programmes such as agriculture, education, industry, commerce, science and technology, health, family planning and forest and environment protection,
 - (b) Such kinds of Programmes as to enhance equality, mutual good faith and harmony amongst all the tribes, languages, classes, areas and religious denominations,
 - (c) Programmes that contribute to the upliftment of various languages and cultures of Nepal,
 - (d) Programmes on such subjects as may enhance the national interest and national unity,
 - (e) Programmes on such subjects as may raise national consciousness and moral awareness,
 - (f) Such kinds of Programmes as to raise social consciousness and develop democratic values, norms and culture in the people,
 - (g) Programmes on such subjects as may not cause adverse impact on the relations between Nepal and neighbouring countries as well as friendly countries,
 - (h) Programmes relating to the foreign policy pursued by the country,
 - (i) Programmes promoting folk songs and folk cultures,

www.lawcommission.gov.np

(j) Important activities happening or taking place at the national and international level.

12. **Participation of private sector in production and broadcasting of Programme**: In addition to the public sector, the private sector may also be got involved so as to make any Programmes fair, simple, efficient and effective.

13. **Time may be allocated to foreign broadcasting institution or communication media**: If any foreign broadcasting institutions or communication media intend to get any Programme broadcast by a broadcasting institution, time may be allocated to broadcast any educational (didactic), entertaining and informative Programmes, based on the prescribed standards, without causing any adverse impact on the national interest.

14. **Time may be allocated to broadcast advertisement**: If any person intends to get any advertisement on publicity of any matter broadcast to the general public, time may be allocated for broadcasting that advertisement, by collecting the prescribed fee from such person, institution or body.

Provided that, the broadcasting of advertisement of substances, such as smoking and liquors, causing harm to the public health shall be discouraged.

⁷15. **Prohibition on broadcasting of advertisement**: (1) Notwithstanding anything contained in Section 14, no one shall broadcast, or cause to be broadcast, any advertisement of the following matters:-

⁷ Revived by the Provisions of Some Nepal Acts Revival Act, 2063

www.lawcommission.gov.np

- (a) Matters adversely affecting political parties,
- (b) Materials of vulgar type,
- (c) Materials with object to oust the elected government by using violent force;
- (d) Matters of such a nature as to create unusual fear and terror in the general public,
- (e) Matters contrary to the non-aligned foreign policy of Nepal,
- (f) Materials misinterpreting disregarding, insulting and devaluing any tribe, language, religion and culture.

(2) Notwithstanding anything contained in Sub-section (1), nothing contained in this Section shall be deemed to prevent Government of Nepal, in consultation with the Election Commission, from allowing any political party to give information about matters such as manifesto, Programme or philosophy of such party, at the time of election.

16. **Functions, duties and powers of broadcaster**: The functions, duties and powers of the broadcaster shall be as follows:-

- (a) To have necessary inquiry as to the truth of the information, news, articles or Programmes received by him and broadcast, or cause to broadcast, them at the specified time,
- (b) To edit and broadcast, or cause to be edited and broadcast, the news by being politically neutral,

www.lawcommission.gov.np

www.lawcommission.gov.np

- (c) Not to broadcast, nor cause to be broadcast, such kinds of Programmes as may undermine public security, moral and social decency,
- (d) Not to broadcast, nor cause to be broadcast, any matters recklessly or negligently,
- (e) Even if broadcasting is to be made about any controversial matter, to broadcast it by analyzing it from all viewpoints to the extent possible, and without twisting the state of affairs,
- (f) Not to collect and broadcast false and illusive news,
- (g) To carry out such other functions as specified by the broadcasting institution.

17. **Penalties:** (1) If any person broadcasts, or causes to be broadcast, any Programme without obtaining the license of broadcasting institution pursuant to Section 6 or without obtaining permission pursuant to Section 9, such person shall be punished, by order of the prescribed authority, ⁸with a fine of a sum equal to the license and permission letter fee and the charge as referred to in Section 10, by recovering such fee and charge or with imprisonment up to One year or with both punishments.

(2) If any person broadcasts, or causes to broadcast, any Programme in contravention of this Act or the Rules framed hereunder or commits, or causes to be committed, any act in contravention of this Act or the Rules framed hereunder, the prescribed authority may punish such broadcasting institution, broadcaster or other related person with ⁹a fine up to Ten thousand

⁸ Amended by Communication Related Some Nepal Acts (Amendment) Act, 2057

⁹ Revived by the Provisions of Some Nepal Acts Revival Act, 2063

rupees or with imprisonment up to One year or with both punishments.

18. **Appeal**: Any person who is not satisfied with any order made or penalties imposed by Government of Nepal or the prescribed authority may file an appeal to the concerned Court of Appeal within Thirty-five days.
19. **Security of broadcasting institution**: If Government of Nepal deems that there is a likelihood of any kind of loss or damage to a broadcasting institution because of a riot or unrest, it may arrange for security by sending security force to that place for such period as it may think necessary.
20. **Delegation of powers**: Government of Nepal may delegate any or all of the powers conferred on it by this Act to any authority or body.
21. **Powers to frame Rules**: Government of Nepal may frame necessary Rules in order to implement the objectives of this Act.
22. **Prevalence of prevailing law**: The matters contained in this Act shall be governed by this Act, and the other matters shall be governed by the prevailing law.
23. **Saving**: Notwithstanding anything contained elsewhere in this Act, a body corporate fully or partly owned by Government of Nepal established prior to the commencement of this Act shall be deemed to have obtained the license of broadcasting institution under this Act.

Annex II

TELECOMMUNICATIONS ACT.2053 (1997)

Publication Date of the Royal Seal and
2053-9-17 (1 Jan. 1997)

Preamble: Whereas, it is expedient to make the Telecommunications service reliable and easily available to the public, involve private sector as well in Telecommunications Service and to regularise and systematize such service;

Now, therefore, Parliament has, in the twenty-fifth year of the reign of His Majesty King Birendra Bir Bikram Shah Dev, made this Act.

Chapter - 1

Preliminary

1. Short Title and Commencement:

- (1) This Act may be called the "Telecommunications Act.2053 (1997)."
- (2) It shall come into force on such date as His Majesty's Government by a notification published in the Nepal Gazette, may appoint.

2. Definitions: Unless the subject or context otherwise requires, in this Act, -

- (a) "Telecommunications" means the act of emission, transmission or reception, through the agency of electricity or electromagnetism, of any sounds, signs, signals, writings, images or intelligence of any nature, by the wire, radio, optical or other electromagnetic systems, whether or not such signs, signals, writings, images, sounds or intelligence have been subjected to rearrangement, computation or other change in any manner for their emission, transmission or reception.
- (b) "Telecommunications Line" means any wire, cable, equipment, tower, mast, antenna, tunnel, hole, pit, pole or other. structure or object used or to be used in connection with a Telecommunications System.
- (c) "Telecommunications System" means equipment or series of equipment used or to be used for the Telecommunications.
- (d) "Telecommunications Service" means a service relating to the acts of the conveyance or reception of any sounds, signs, signals, writings or images by the wire, radio, optical or other electromagnetic systems whether or not such signs, signals, writings, images, sounds or intelligence have been subjected to rearrangement, computation or other change in any manner for their emission, transmission or reception.
- (e) "Authority" means the Telecommunications Authority established pursuant to Section 3.

- (f) "Chairman" means the Chairman of the Authority.
- (g) "Member" means the Member of the Authority and the terms also includes the Chairman.
- (h) "Licence" means the licence issued pursuant to Section 24 to operate the Telecommunications Service.
- (i) "Licencee" means a person having obtained the Licence to operate the Telecommunications Service pursuant to Section 24.
- (j) "Customer" means the person who receives the Telecommunications Service made available by the Licencee.
- (k) "Charge" means the fees to be realized from the Customer for the Telecommunications Service provided pursuant to this Act.
- (l) "Person" includes a corporate body established pursuant to the prevalent laws.
- (m) "Prescribed" or "As Prescribed" means prescribed or as prescribed in the Rules or By-laws framed under this Act.

Chapter - 2

Establishment and Constitution of the Telecommunications Authority

Establishment of Telecommunications Authority:

A Nepal Telecommunications Authority is established with a view to managing and regularizing the Telecommunications Service and making it reliable and easily available to the public.

Authority to be an Autonomous and Corporate Body:

- (1) The Authority shall be an autonomous and corporate body with perpetual succession.
- (2) The Authority shall have its own seal to carry out its functions.
- (3) The Authority may, like an individual, acquire, use or otherwise manage movable and immovable property.
- (4) The Authority may, like an individual, sue and be sued by its name.

Constitution of the Authority:

- (1) The Authority shall consist of five Members including the Chairman who are qualified and experienced, as prescribed in the financial, technical, market management, accounts and auditing or legal field relating to the Telecommunications Service.
- (2) His Majesty's Government shall constitute a committee comprising of experts from the related sectors, to make recommendation for the appointment of the Chairman and

Members of the Authority and His Majesty's Government shall on the recommendation of the said committee appoint the Chairman and Members of the Authority.

(3) The Authority may, if it deems necessary, invite any expert to participate in the meeting of the Authority as an observer.

(4) The Officer designated by the Chairman from amongst the employees of the Authority shall act as the Secretary of the Authority.

Office of the Authority:

The Central Office of the Authority shall be located in the Kathmandu Valley and the Authority may open branch offices well within the Kingdom of Nepal, as per necessity.

Meeting of the Authority and Decision:

(1) The meeting of the Authority shall be held as per necessity.

(2) The meeting of the Authority shall be held on such place, date and time as specified by the Chairman.

(3) The meeting of the Authority shall be presided over by the Chairman and in his absence the meeting shall be presided over by a Member selected by the Members present at the meeting from among themselves.

(4) The presence of more than fifty percent Members shall be deemed to be completed a quorum for a meeting.

(5) The opinion of the majority at a meeting of the Authority shall be deemed to be the decision of the Authority and in the event of a tie, the Chairman shall exercise the casting vote.

(6) The decisions of the meetings of the Authority shall be attested by the Chairman, and such decisions shall be circulated to all the Members by the Secretary of the Authority.

(7) Other procedures relating to the meetings of the Authority shall be as determined by the Authority itself.

Tenure of the Chairman and Members:

(1) The tenure of service of the Chairman and Members shall be of five years.

(2) In case the committee pursuant to sub-section (2) of Section 5 recommends for the reappointment of the Chairman and Members showing their performance to be satisfactory, His Majesty's Government may reappoint him to the post of Chairman and Member.

To Remove the Chairman and the Member from the Post:

(1) Notwithstanding anything contained in Section 8, His Majesty's Government may remove the Chairman or Member from the post in the following circumstances -

(a) Absence of competency to work,

- (b) Misconduct,
 - (c) Failure to carry out the official duty assigned to him, honestly,
 - (d) Become mentally disorder or insane, or
 - (e) Having direct or indirect ownership or personal interest in any firm or corporate body which operates the Telecommunications Service or System.
- (2) Before removing the Chairman or the Member from the post pursuant to sub-section (1), he shall be provided a reasonable opportunity to submit his clarification.

10. Vacancy of the Post of the Chairman and the Member:

The post of the Chairman and the Member shall be deemed to be vacant in the following circumstances: -

- (a) If his written resignation tendered to His Majesty's Government is accepted,
- (b) If he completes his tenure pursuant to Section 8,
- (c) If he is removed from his post pursuant to Section 9,
- (d) If he is convicted of any criminal offences from the court, or
- (e) If he dies.

11. The Terms and Conditions of Service of the Chairman:

- (1) The Chairman shall be the full time working chief executive officer of the Authority.
- (2) The remuneration, facilities and other terms and conditions of service and functions, duties and power of the Chairman shall be as prescribed.
- (3) After the appointment of a person as the Chairman, his remuneration, facilities and other terms and conditions of service shall not be altered to his disadvantage.
- (4) The Member shall obtain the meeting allowance as prescribed for attending the meetings of the Authority.

12. Employees of the Authority:

- (1) The Authority shall consist of the employees as required for the operation of its functions.
- (2) The appointment, remuneration, facilities and other terms and conditions of service of the employees pursuant to sub-section (1) shall be as prescribed.
- (3) Notwithstanding anything contained in sub-section (2), His Majesty's Government may, at the request of the Authority, depute the employees of His Majesty's Government or any corporate body to the Authority with the remuneration to be received from the Authority until the appointment of the employees of the Authority.

Chapter - 3

Functions, Duties and Powers of the Authority

Functions and Duties of the Authority:

The functions and duties of the Authority shall be as follows: -

- (a) To provide suggestions to His Majesty's Government on the policy, plan and programme to be adopted by His Majesty's Government for the development of the Telecommunications Service.
- (b) To make the Telecommunications Service reliable and easily available to the public.
- (c) To make necessary arrangement to avail basic Telecommunications Service and facilities in all rural and urban areas throughout the kingdom of Nepal.
- (d) To involve the national and foreign private sector investors in the operation of the Telecommunications Service.
- (e) To make arrangement for the coordination and healthy competition among the persons providing Telecommunications Service and facilities, so as to provide such service and facilities to all public in general.
- (f) To prescribe, fix and approve the standard and quality standard of the plant and equipment relating to the Telecommunications and the Telecommunications Service.
- (g) To regularise and systematize Telecommunications Service
- (h) To grant Licence to operate the Telecommunications service in private sector.
- (i) To approve and regularise the fees to be collected by a person having obtained Licence for providing the Telecommunications Service.
- (j) To perform the functions relating to the frequency in accordance with the policy determined by the Radio Frequency Policy Determination Committee.
- (k) To carry out or cause to carry out the research about the development and use of new technology in the field of Telecommunications.
- (l) To cause to develop the skilled manpower for the Telecommunications Sector.
- (m) To develop and extend or cause to develop and extended the Telecommunications Service in such a way that it protects the rights and interests of the consumers.
- (n) To develop or cause to develop Nepal as an International Transit for Telecommunications.
- (o) To carry out necessary and appropriate functions for the development and promotion of the Telecommunications Service.

14. Determination of Quality and Standard of Service:

- (1) The Authority shall determine the quality and standard of the machine, equipment and facilities relating to the Telecommunications and the Telecommunications Service.

The Authority shall Prescribe the minimum standard to be maintained by a Licencee in operating the Telecommunications Service.

15. Power to Issue Orders or Directives:

(1) The Authority may, in view of the policy and guidelines of His Majesty's Government, issue necessary orders or directives to the Licencee and it shall be the duty of the concerned person to comply with such orders or directives.

(2) The Authority may require the particulars of the activities carried out by the Licencee and the particulars related to the Telecommunications Service operated by the Licencee and it shall be the duty of the concerned person to provide such particulars.

Power to Settle Dispute:

(1) The Authority shall have the power to settle disputes between the Licencees or between the Licencee and the Customer relating to the Telecommunications Service.

The method and procedure of the settlement of the disputes pursuant to sub-section (1) shall be as prescribed.

Inspection and Investigation:

(1) The Authority may, if it deems necessary, inspect or investigate the activities carried out or the services provided by the Licencee, at any time.

(2) The Authority may, for the purpose of inspection or investigation pursuant to sub-section (1), designate any person or body of the Authority.

(3) It shall be the duty of the concerned Licencee provide information or particulars and documents required by the Authority or the person or body designated pursuant to sub-section (2) in course of the inspection or investigation.

(4) The procedures to be followed in course of inspection or investigation pursuant to this Section, the report thereof and the provisions relating to the execution of the report shall be as prescribed.

Chapter - 4

Special Powers of His Majesty's Government

Power of His Majesty's Government to Operate or Cause to Operate the Telecommunications Service by itself:

Notwithstanding anything contained elsewhere in this Act, His Majesty's Government may operate the Telecommunications Service by itself or cause it to be operated.

19. Special Powers of His Majesty's Government:

(1) In case it requires to stop the transmission of information or to control transmission system due to the state of emergency or national security, His Majesty's Government may carry out the following acts: -

(a) To take temporarily the Telecommunications Line and the Telecommunications System installed, operated or supervised by the Licencee under its possession,

(b) To order to tape the information, to trace the transmitter of the information or to stop such informations related to any specific subject, person or community.

(2) After the expiry of the circumstance pursuant to sub-section (1), the Telecommunications Line and Telecommunication System so possessed by His Majesty's Government shall be returned to the concerned Licencee.

20. Power to Issue Directives:

His Majesty's Government may, from time to time, issue necessary directives to the Authority in connection with the diversification, extension and regularization of the Telecommunications Service in line with the Telecommunications policy of the country and it shall be the duty of the Authority to comply with such directives.

Chapters - 5

Provisions for Licence

Prohibition to Operate Telecommunications Service without Licence:

After the commencement of this Act, no one may operate the Telecommunications Service without obtaining a Licence.

22. Notice to be Published to Submit Application for Licence:

(1) The Authority shall, before issuing any Licence relating to any Telecommunications Service other than those prescribed pursuant to sub-section (2) of Section 23, determine the number of Licence to be issued for such service and types of Telecommunications and publish a public notice specifying the time limit to submits application for the Licence.

(2) Within the period of five years from the date of issue of the Licence of any Telecommunications Service pursuant to sub-section (1), no other Licence shall be issued to operate the same Telecommunications Service.

Provided that, this sub-section shall not bar the Authority from issuing the Licence to other person in cased the Licencee fails to provide the Telecommunications service as prescribed in the Licence or on the basis of subjective evaluation if it seems that the additional service for such Telecommunications Service is required.

23. Application to be Submitted for Licence:

(1) The person, who desires to operate the Telecommunications Service pursuant to this Act and has capital, technical expertise and professional experience as prescribed, shall have to submit an application to the Authority, setting out the particulars as prescribed along with economic and technical study report as well as work plan in connection with the Telecommunications Service to be operated, within the time prescribed by the Authority pursuant to Section 22.

(2) Notwithstanding anything contained in sub-section (1), application may be submitted at any time for the Licence to operate the Telecommunications Service as specified by His Majesty's Government by a notification published in the Nepal Gazette on the recommendation of the Authority and the number of Licence and process shall be as specified in that notice.

(3) The persons, who have been operating the Telecommunications Service since before the commencement of this Act, shall be required to submit an application to the Authority for the Licence setting out the particulars relating to the service having been operated by them, within six months and shall have to receive the Licence within one year from the date of the commencement of this Act.

24. Provision of Licence:

(1) Upon the receipt of the application pursuant to Section 23, the Authority shall conduct necessary inquiry in this regard, and in course of inquiry, if it deems necessary to ask for an additional information or particulars, the Authority may ask for the additional information or particulars from such applicant.

(2) After the inquiry by the Authority pursuant to sub-section (1), if it deems appropriate to issue the Licence, the Authority shall issue the Licence to the applicant upon receiving the fee as prescribed, other than the Licence to be issued pursuant to sub-section (3) and (4).

(3) While making an inquiry pursuant to sub-section (1), if only one person from among the applicants who submitted the application pursuant to sub-section (1) of Section 23 is found to be qualified to operate such Telecommunications Service, the Authority may fix Licence fee, renewal fee as well as royalty by negotiation with such person and shall issue the Licence to him.

(4) While making an inquiry pursuant to sub-section (1), if more than one persons are found to be qualified to operate such Telecommunications Service from among the applicants, the Authority may notify all of these persons for bidding in connection with the Licence fee, renewal fee as well as royalty and shall issue the Licence to the person who quotes maximum amount in the bidding.

(5) While issuing a Licence pursuant to sub-section (2), the Authority shall issue the Licence within ninety days of the receipt of the application or of the receipt of them additional information or particulars if such information or particulars are required pursuant to sub-section (1).

(6) While issuing a Licence pursuant to sub-section (3) or (4), the Authority shall issue the Licence within one hundred and twenty days from the last day prescribed for the

submission of the application pursuant to sub-section (1) of Section 23 or from the date of the receipt of the additional information or particulars, if such information or particulars are required pursuant to sub-section (1).

(7) A person, who could not obtain the Licence within the time stipulated in sub-section (5) or (6), may file a complaint to His Majesty's Government within thirty days of the expiry of such time limit and the decision of His Majesty's Government in such complaint shall be final.

25. Period of Licence and Renewal:

(1) The period of Licence shall be of twenty-five years at the maximum.

Provided that, the Licence shall not be issued for a period of more than ten years at a time.

(2) A Licencee desiring to have his Licence renewed shall be required to submit an application to the Authority for the renewal of the Licence before the expiry of the period of the Licence within the prescribed period. If an application is so made, the Licence shall be renewed for a period of not more than five years at a time.

(3) The Licencee pursuant to sub-sections (3) and (4) of Section 24 shall deposit the renewal fee as agreed by him to the Authority for the purpose of the renewal of the Licence pursuant to sub-section (2).

(4) The Licencee pursuant to sub-section (2) of Section 24 shall deposit the renewal fee as prescribed to the Authority for the purpose of the renewal of the Licence pursuant to sub-section (2).

(5) In case the Licence is not renewed within the time limit pursuant to sub-section (2), such Licence shall ipso facto be invalid.

Amendment to the Licence:

(1) In case a Licencee deems it necessary to make any amendment to any matter set forth in the Licence obtained by him, such Licencee shall submit an application to the Authority stating the reasons thereof.

(2) If the reasons for the amendment to the Licence mentioned in the application submitted pursuant to sub-section (1) are found reasonable and appropriate, the Authority shall amend the Licence within thirty days of the receipt of such application, if it does not affect the substantial matters mentioned in the Licence, if it does not seem necessary to amend the Licence, a notification to that effect with reasons shall be given to the applicant.

(3) A fee as prescribed shall be required to deposit in the Authority for the amendment to the Licence pursuant to sub-section (1).

(4) In case the Authority deems it necessary to make any amendment mentioned in any Licence the Authority may give notice to that effect to the concerned Licencee stating the reasons thereof.

(5) On the receipt of the notice pursuant to sub-section (4), if the Licencee deems no such amendment is required to his Licence, such Licencee may submit an application to that

effect to the Authority stating the reasons thereof within fifteen days of the receipt of such notice.

(6) Upon the receipt of an application pursuant to sub-section (5) or upon the expiry of that time limits, the Authority shall decide whether to make or not to make amendment to the Licence and notify the Licencee thereof.

27. Sale or Transfer of Licence:

(1) In case a Licencee desires to sell or transfer his Licence to any other person, the Licencee and the buyer or the transferee of the Licence shall have to submit a joint application to the Authority stating the reasons thereof along with the terms and conditions mutually agreed, for the approval.

(2) Upon the receipt of an application submitted pursuant to sub-section (1), while making an inquiry by the Authority, if it deems appropriate to sell or transfer the Licence to the person mentioned in the application, the Authority shall grant approval for such sell or transfer within thirty days of the receipt of the application, and if it deems inappropriate to permit to sell or transfer, a notification with reason shall be given to the applicant.

(3) A fee as prescribed shall be required to be paid to the Authority for the approval to sell or transfer the Licence.

28. Licence May be Cancelled:

(1) In case the Licencee fails to operate the Telecommunications Service within the time limit as specified in the Licence, the Authority may cancel such Licence.

(2) If the Licencee acts in contravention of this Act or the Rules made thereunder and the terms and conditions set forth in the Licence, the Authority may issue an order to the concerned Licencee to improve on such acts specifying the time thereof.

(3) If the Licencee fails to improve the acts within the period specified pursuant to sub-section (2), the Authority may cancel the Licence of such person.

(4) Notwithstanding anything contained in sub-section (1) or (3), the Licencee shall be provided a reasonable opportunity to submit his clarification.

(5) A Licencee not satisfied with the cancellation of the Licence by the Authority pursuant to sub-section (3), may file a complaint to His Majesty's Government within thirty-five days and the decision of His Majesty's Government in such complaint shall be final.

29. Terms and Conditions to be Complied With by the Licencee:

The terms and conditions other than those mentioned in this Act to be complied with by the Licencee shall be as prescribed.

30. To Develop, Expand and Operate the Telecommunications Service in the Directed Area:

(1) The Licencee pursuant to sub-sections (3) and (4) of Section 24 shall invest the prescribed percent of his total investment for the development, extension and operation of the Telecommunications Service in the rural area.

(2) The rural area, in which the Licencee is required to extend the Telecommunications Service pursuant to sub-section (1), shall be as mentioned in the Licence and in case it is not mentioned in the Licence, it shall be as specified by the Authority from time to time.

(3) If any Licencee, on the basis of mutual agreement, wishes to develop, extend and operate the Telecommunications Service to be developed, extended and operated by other Licencee pursuant to sub-section (1) and (2), the Authority may after making necessary inquiry, grant its approval.

(4) The Authority shall create a fund for the development, extension and operation of the Telecommunications Service in the rural area and the Licencee shall deposit such amount, every year, out of the annual income received by him as specified by the Authority.

(5) The Authority shall use the amount deposited in the fund pursuant to sub-section (4) for the development, extension and operation of the Telecommunications Service in the rural area subject to the policy of His Majesty's Government relating to the Telecommunications.

(6) The Authority may designate any Licencee for developing extending or operating the Telecommunications Service pursuant to sub-section (5) and such Licencee shall develop extend and operate the Telecommunications Service in the rural are as specified by the Authority.

31. Interconnection and Use of Telecommunications System Allowed:

(1) The Licencee shall be allowed to mutually connect the Telecommunications System developed by him with the Telecommunications System developed by other Licencee and use it.

(2) If a Licencee requests, to connect and use the Telecommunications System developed by another Licencee the Licencee shall be allowed to connect and use on the terms and conditions mutually agreed upon or on the terms and conditions determined by the Authority, if such agreement could not be reached.

32. Royalty to be Paid:

(1) The Licencee pursuant to sub-section (2) of Section 24 shall be required to pay royalty to His Majesty's Government as prescribed.

(2) The Licencee pursuant to sub-sections (3) and (4) of Section 24 shall be required to pay royalty to His Majesty's Government as promised by him.

(3) The method of payment of royalty and the time shall be as specified by the Authority.

33. To be Owned by His Majesty's Government:

(1) The land, building, plant, equipment and other structures related to the Telecommunications service developed with more than fifty percent of its investment by a foreign person or corporate body shall be under the ownership of His Majesty's Government after the expiry of the period of the Licence.

(2) The assets so owned by His Majesty's Government pursuant to sub-section (1) may be purchased by the previous Licencee upon payment to His Majesty's Government at a price fixed pursuant to sub-section (3) and after obtaining the Licence once again, the Telecommunications Service may be operated.

(3) For the purpose of fixation of price mentioned in sub-section (2), His Majesty's Government may, in consultation with the Authority, constitute a committee consisting five members at the maximum.

(4) In case of the Telecommunications Service operated with the investment of foreign person or corporate body up to fifty percent, the previous Licencee may, after the expiry of the period of the Licence, operate the Telecommunications Service by obtaining the Licence once again.

Chapter - 6

Facilities to be Obtained by the Licencee

34. Facilities Relating to Tax and Charges:

(1) If his Majesty's Government deems necessary for encouraging investment in the services relating to the Telecommunications, His Majesty's Government may, by a notification published in the Nepal Gazette, exempt the Licencee from income tax for a specific period.

(2) His Majesty's Government may, by a notification published in the Nepal Gazette, exempt fully or partially, the customs duty, sales tax and other Charge to be levied on the import of such equipment relating to Telecommunications as mentioned in such notification.

35. Foreign Exchange Facility:

(1) If foreign currency is invested as loan or share capital for the purpose of providing the telecommunications Service, His Majesty's Government shall avail necessary foreign currency at the prevailing exchange rate for the purpose of payment of such loan, the interest there of or repatriation of the investment.

(2) If a Licencee is required to import the equipment necessary to operate the Telecommunications Service from abroad, His Majesty's Government shall avail the foreign currency required for such import, at the prevailing exchange rate.

Chapter - 7

Installation and Supervision of Telecommunications Line

36. Right to Use Land:

The Licencee or his representative may install or keep and supervise the telecommunications Line on or upon any public or private land and for this purpose may fix a pole or mast and if the land consists any tree, the Licencee may keep anything or support on such tree or may cut the tree, if it creates problem, loss or damage or obstacle to the Telecommunications Line.

Provided that, -

(1) If the land, where such Telecommunications Line is installed or is to be installed, is a public land, no compensation shall be required to pay for such land, and if any loss or damage is caused to any public property constructed or installed on such land, the Licencee shall be required to repair and maintain or reconstruct so as to bring it in the previous position.

(2) If the land, where such Telecommunications Line is installed or is to be installed, is a private land, such line shall be installed at the proper and appropriate place without causing any loss or damage to such person and in case any loss or damage is caused to such person in course of installation, the Licencee shall be required to pay compensation.

(3) The status of the Licencee in the land where the Telecommunications Line is kept or installed, shall be as a user of the Telecommunications Line and he shall have no other rights on such land.

37. Power To Inspect, Repair or Transfer the Telecommunications Line From One Place to Another Place:

The Licencee may transfer from one place to another place, inspect or repair and maintain the Telecommunications Line or equipment erected or installed by him and for this purpose he shall have the power to enter into the land where such Telecommunications Line or equipment exists.

Provided that, if any loss or damage is caused to anyone in course of such repair and maintenance or improvement of the line, the Licencee shall pay compensation to the concerned person.

38. Entrance to Other's House and Land:

In course of operation of the Telecommunications Service, if the Licencee is required to enter into anyone's premises, he shall enter into such premises only after giving a prior written notice to the concerned person. In case any loss or damage is caused due to such entrance, the Licencee shall pay compensation to the concerned person.

Provided that, if there is sufficient ground to suspect that the Telecommunications Service is being unauthoritatively used or theft on any premises, the Licencee may enter into the

concerned premises for the inspection of such matter, giving at written notice at once to the concerned person.

39. Provisions Relating to Compensation:

(1) The amount of compensation to be paid by the Licencee pursuant to Sections 36, 37 and 38 shall be determined within fifteen days from the date of such event and a notice shall be given to the concerned person.

(2) The amount of compensation to be paid pursuant to sub-section (1) shall be proper and reasonable.

(3) A person not satisfied with the amount of compensation determined pursuant to sub-section (1), may submit an application accompanied with reasons to the Authority within fifteen days of the receipt of the notice thereof. The decision of the Authority in this regard shall be final.

40. Use or Acquisition of Other's House and Land:

(1) If the Licencee requires to use or acquire others premises for the purpose of expansion or distribution of the Telecommunications Service and fails to obtain or use the premises from the concerned person, the Licencee may submit an application accompanied with the details to the Authority for the obtaining or use of such premises.

(2) Upon receipt of an application pursuant to sub-section (1), the Authority shall make necessary inquiry and upon such inquiry if it deems necessary and appropriate to acquire the premises as mentioned in the application, the Authority shall forward its recommendation thereof to His Majesty's Government within thirty days of the receipt of the application.

(3) Upon the receipt of the recommendation of the Authority pursuant to sub-section (2); His Majesty's Government may provide such premises to the Licencee as it is provided to the corporate body pursuant to prevalent law. If it is government land, such land may be availed on lease for the period of the Licence.

Chapter - 8

Fixation and Realization of Service Charge

41. Service to be Availed:

(1) If the Licencee has received deposit from the Customer to avail the Telecommunications Service, such service shall be availed within six months of the receipt of the deposit from the Customer, and if the Licencee fails to avail such service within that time, an interest at the rate of the ten percent shall be paid to the Customer from the date of receipt of the deposit. Provided that, the service shall be availed within one year of the receipt of the deposit.

(2) The interest to be paid to the Customer pursuant to sub-section (1) may be deducted from the service charge payable by the customer.

42. Service Charge:

(1) The Licencee may levy and realize Service Charge for the Telecommunications Service availed by him to the Customer -

Provided that -

(a) The rate of such Service Charge shall have to be approved by the Authority.

(b) The rate of such Service Charge shall be published as directed by the Authority.

(c) The rate of such Service Charge shall be proper and reasonable.

(2) For the purpose of sub-section (1), the Licencee shall be required to prepare the list of Service Charge on the basis of guidelines issued by the Authority and shall submit the list stating the date of its enforcement; to the Authority at least three months in advance of such date.

(3) The Licencee shall not unduly discriminate on the service charge and other terms and conditions or give undue priority to anybody including himself or cause undue loss or damage to anybody.

43. Service may be Stopped:

The Licencee may stop the Telecommunications Service availed to the customers on the following circumstances: -

(a) If it requires to inspect, repair or extend or to do any other important work on the Telecommunications Line or the Telecommunications System,

(b) If any Customer fails to pay the charge payable by him, for such Customer,

(c) If any Customer uses the service unauthoritatively or in contravention of the terms and conditions, for such Customer,

(d) If there appears such events as natural calamity or strike, lockout, riot or similar other events beyond the control.

Chapter - 9

Fund, Account and Audit of the Authority

44. Fund of the Authority:

(1) The Authority shall have its own separate fund and the fund shall consist of the following amounts: -

(a) Amount received from His Majesty's Government.

(b) Amount received as fee for the issuance and renewal, amendment sale or transfer of the Licence.

(c) Amount received as grant from foreign government, organization or association.

(d) Amount received from any other sources.

(2) The Authority shall obtain the approval of His Majesty's Government before receiving any amount pursuant to Clause (c) of sub-section (1).

(3) The amount of the fund of the Authority shall be deposited to any bank within the Kingdom of Nepal and such bank account shall be operated as specified by the Authority.

45. Budget and Expenditure:

(1) The Authority shall cause to prepare its budget every fiscal year and approve it for the operation of the functions pursuant to this Act.

(2) All the expenditures of the Authority, shall be borne from the fund of the Authority, subject to the approved budget pursuant to sub-section (1).

(3) In case the amount, received by the Authority every year pursuant to Clauses (b), (c) and (d) of sub-section (1) of Section 44, becomes insufficient to carry out the functions pursuant to this Act, the Authority may request to His Majesty's Government for such deficit amount, and in case the amount so provided by His Majesty's Government is in excess the Authority shall pay such excess amount to His Majesty's Government.

46. Account of the Authority and Audit:

(1) The accounts of the income and expenditure of the Authority shall be maintained in accordance with the prevalent laws.

(2) The audit of the accounts of the Authority shall be done by the Auditor - General.

(3) His Majesty's Government may, if it deems necessary, inspect or cause to inspect the accounts of the Authority at any time.

Chapter - 10

Punishment and Appeal

47. Punishment:

(1) If a person contravenes the provisions of this Act or the Rules made thereunder or fails to uphold the orders or directives by the Authority, the Authority may award a fine of up to Fifty Thousand Rupees to such person, and if any loss or damage is caused to anybody due to such offence, the Authority may cause to realize the amount of such damage or loss or also the compensation thereof from the offender.

(2) If any person operates the Telecommunications Service without obtaining the Licence pursuant to this Act or operates the Telecommunications Service without complying with

the terms and conditions mentioned on the Licence, the Authority may award a fine up to Fifty Thousand Rupees to such person and may also cause to stop such act.

(3) If a person misuses or unauthoritatively uses the Telecommunications Service or causes loss or damage to any property related to the Telecommunications Service, the Authority may realize the amount of such loss or damage tend may impose a fine according to the amount.

(4) If a person abuses; threatens or causes unnecessary harassment through the Telecommunications Service, the Authority may award a fine of up to Twenty Five Thousand Rupees to such person and may also cause to stop such service.

Provided that, before stopping the Telecommunications Service, the Authority shall provide the concerned person with proper opportunity of his clarification.

(5) If a person acts intentionally to cause adverse effect damage or cause any other loss or damage to the Telecommunications Line, Telecommunications System or the equipment or any other structure related to such Telecommunications Line or Telecommunications System or induces for such acts or attempts to do such acts such person may be fined with an amount equal to loss or damage as well or punished with an imprisonment for a term not exceeding five years or with both punishment according to the degree of crime.

48. Appeal:

A person who is not satisfied with the order issued by the Authority pursuant to sub-sections (1), (2) (3) and (4) of Section 47 may appeal within 35 days to the prescribed committee and the decision of such committee shall be final in regard to that appeal.

Chapter - 11

Miscellaneous

49. Provisions on Determination of Radio Frequency Policy:

(1) There shall be a Radio Frequency Policy Determination Committee for the purpose of determining the policy relating to the radio frequencies and allocation comprising the chairman and the member as follows: -

(a) Minister or Minister of State,

Information and Communications - Chairman

(b) Secretary, Ministry of Home - Member

(c) Secretary, Ministry of Defence - Member

Secretary, Ministry of Tourism and Civil Aviation - Member

(e) Secretary, Ministry of Information and Communications - Member

(f) Chairman, Nepal Telecommunications Authority - Member

(g) At least Gazetted first class or expert Officer equivalent

there to designated by His Majesty's Government - Member - Secretary

(2) The functions, duties and powers of the committee constituted pursuant to sub-section (1) shall be as follows: -

(a) To determine the policy relating to radio frequency.

(b) To fix and allocate the radio frequency for different services.

(c) To determine the pricing policy of radio frequency.

(d) To determine the policy for international and mult purpose coordination of radio frequency.

(3) Other functions, duties and powers and procedures relating to the meeting of the committee constituted pursuant to sub-section (1) shall be as prescribed.

50. Constitution of Sub-committee or Task Force:

(1) The Authority may, as it deems necessary, constitute sub-committee or task force for the operation of its function smoothly.

(2) The functions, duties and powers and other procedure of the sub-committee or task force constituted pursuant to sub-section (1) shall be as specified by the Authority.

51. Oath To be Taken:

Before assuming the office, the Chairman and Members shall take oath before the Minister or Minister of State for Information and Communications as mentioned in the Schedule.

52. To Prepare and Implement the Guidelines:

(1) The Authority may prepare and implement the Guidelines on the following subjects: -

(a) Regarding to the interconnection and use of the Telecommunications System developed by the Licencee.

(b) Regarding to the fixation of Service Charge and other fees to be levied and realized for the Telecommunications Service availed by the Licencee.

53. Acts Done by the Authority Not to be Invalid:

The acts done or actions taken by the Authority, shall not be invalid only due to the reason that the post of a Member of the Authority has fallen vacant or any error in the constitution of the Authority.

54. Case not to be Initiated:

No case shall be initiated in any court for the acts or actions done in good faith in course of carrying the duty pursuant to this Act by the Authority or any Member or employees of the Authority or any person or office designated or delegated by the Authority.

55. Annual Report:

(1) The Authority shall submit the annual report of its activities carried out during that year to His Majesty's Government within three months of the expiry of every fiscal year.

(2) The Authority shall publish the report submitted pursuant to sub-section (1) for the notification of the public in general.

56. Delegation of Authority:

The Authority may, as per necessity, delegate some of the powers conferred upon it pursuant to this Act or the Rules made pursuant to this Act, to the Chairman or sub-committee or task force constituted pursuant to Section 50 or staff of the Authority.

57. His Majesty's Government to be Plaintiff:

His Majesty's Government shall be plaintiff in the cases pursuant to sub-section (5) of Section 47 and such cases shall be deemed to be included in Schedule- 1 of the Government Cases Act, 2049 B S. (1992 A.D.).

58. Liaison with His Majesty's Government:

The Authority shall make liaison with His Majesty's Government through the Ministry of Information and Communications.

59. Existing Laws to Prevail:

This Act shall prevail on the matters provided for in this Act and in other matters the existing law shall prevail.

60. Power to Remove Difficulties:

(1) If any difficulty arises in the implementation of this Act, His Majesty's Government may, issue necessary order by a notification published in the Nepal Gazette, to remove such difficulties without any inconsistency with the provisions of this Act.

(2) Each order issued pursuant to sub-section (1) shall be presented to the Parliament as soon as possible.

61. Power to Frame Rules:

(1) His Majesty's Government may frame necessary Rules for the implementation of the objectives of this Act.

(2) Without prejudice to the generality of the powers conferred by sub-section (1), His Majesty's Government may frame Rules on the following subjects.

- (a) Format of an application to be submitted for the Licence and particulars to be incorporated thereon, format of the Licence and terms and conditions, fee for the Licence and renewal fee, and royalty.
- (b) Format of an application to be submitted for the amendment to the Licence or sale or transfer of the Licence and particulars to be incorporated thereon and the fee payable for it.
- (c) The terms and conditions to be complied with by the Licensee during the operation of the Telecommunications Service and matters relating to the standard of service to be provided to the customers.
- (d) Method and procedure for the distribution of frequency.
- (e) Other necessary matters.

62. Power to Make Bye-Laws:

The Authority may subject to the provisions of this Act and the Rules made thereunder, make necessary Bye-laws.

63. Repeal and Saving:

- (1) The Telecommunications Act, 2019 (1962 A.D.) is hereby repealed.
- (2) All the acts and actions done and carried out pursuant to the Telecommunications Act, 2019 (1962 A.D.) before the commencement of this Act, shall be deemed to be done and carried out pursuant to this Act.

Schedule

(Related to Section 51)

OATH

I..... swear in the name of God/ with trust and faith that I will faithfully discharge the duties of the post of Chairman/ Member with allegiance to the Telecommunications Act, 2053 (1997 A. D.) without Fear, favour, affection, ill will or greed and I will not in any circumstances other than in accordance with prevalent laws, disclose any matter which shall be known to me in course of performance of my duties.

Date: -.....

Signature

.....

Annex III

Report of the Frequency Recommendation Working Group

1 Background

Recent international surveys show that, in comparison to voice communication, use of wireless broadband for mobile internet access has significantly increased worldwide. As per GSMA predictions, by the year 2013 there would be over 2.4 billion wireless internet uses across the globe that would browse through new generation smart phones or laptops instead of fixed connections. The current mobile frequencies, allocated for various conventional and new generation technologies, such as CDMA/EvDO, GSM, GPRS, HSDPA, etc., are limited and confined within 800, 900, 1800 and 2100 MHz bands. However, these bands are almost exhausted with no room for further expansions for more promising forthcoming technologies, like LTE and WiMAX.

A large portion of UHF bands – IV/V from 470 MHz to 862 MHz has been currently occupied by terrestrial analog television broadcasting. Some of the frequencies in this band are also used by other service providers, such as, services ancillary for broadcasting (i.e. wireless microphones, live relay, etc.), live broadcast link, wireless communication for public protection & disaster relief (PPDR) and cognitive technologies. It is evident that due to technological advancements in broadcasting, lots of frequencies could be easily vacated in this band through digital transmission. Through DTT it is possible to transmit several TV/Radio channels simultaneously utilizing same carrier and same bandwidth, contrary to only one with analog broadcasting. The “digital dividend” is a term used to describe the spectrum freed up as result of the switchover from analog to digital television transmission (DTT). Therefore, countries around the world are looking for the possibilities of vacating some of the frequencies in this band to give way for broadband wireless access and newer generation mobile services.

700 MHz band is generally referred to as the bandwidth in between 698 to 806 MHz. This entire band was unanimously adopted by WRC-07 as the future IMT band and was recommended by ITU to its Member States to free-up as soon as practicable. According to Nepal's "National Frequency Plan 2061", frequency band 470 to 862 MHz has been allocated for Fixed, Mobile and Broadcast radio transmissions. While lower frequencies up to 540 MHz have already been assigned to NTV and other private terrestrial television broadcasters, most of it is still vacant. It should be noted that countries around the world are trying to vacate 700 MHz band frequencies for fulfilling demands of future technologies, it is high time for the Government of Nepal to make a proper policy to allocate this precious frequency band in most efficient manner. Taking this into consideration, MOIC has formed a committee to study the allocation status in UHF bands IV and V and 2.6 GHz and come up with recommendations with a view to implementing a proper spectrum management and licensing framework.

2 Terms of reference

On 2067/08/13, the Ministry of Information & Communication (MOIC) formulated a Working Group, hereinafter referred to as “Frequency Recommendation Working Group” (FRWC) to carry out the study as per following Terms of Reference. The FRWC consisted of the following 6 members from various departments:

1. Mr. Nirmal K. Pradhanang – Chairman IETE Nepal Chapter, Coordinator
2. Mr. Anup Nepal – Under Secretary, MOIC, Member
3. Mr. Gaurav Giri – Under Secretary, MOIC, Member
4. Ms. Shailaja Regmi (Bhattarai) – Under Secretary, MOIC, Member

- 5. Mr. Ambar Sthapit – Deputy Director, NTA, Member Secretary
- 6. Mr. Deepak Dhital – Chief Engineer, Nepal Television, Member

Following Terms of Reference (TOR) was given to FRWG by MOIC, vide their letter 7/067/68-846 dated 2067/08/13.

- a) Prepare a Band Plan and Frequency Distribution Methodology for Terrestrial Television Broadcasting in UHF Band.
- b) Recommend an administrative policy for issuance of Government Licenses for operation of UHF TV Stations and Network in the country.
- c) Recommend possible classifications of UHF TV broadcasting stations taking into consideration of their effective radiated power, coverage and coexistence with other telecommunication facilities.
- d) Carry out a detailed study and make recommendations for the possible use of Long Term Evolution (LTE) technology along with Television in UHF Band and how 700/2600 MHz bands must be utilized for various services.
- e) Prepare a migration plan from analog to digital television broadcasting and recommend appropriate policy and legal aspects that must be considered for such transition.
- f) In the process of study, if deemed necessary, the working group may study other relevant subjects and provide recommendations as appropriate.

The working group may invite any other relevant people as per requirement.

3 World trends in terrestrial TV broadcasting

3.1 Broadcasting frequencies

Until the satellite television came into existence, terrestrial transmission played vital role in television broadcasting worldwide. For PAL B/G transmission, bandwidth required for each carrier is 8 MHz. Therefore, taking into consideration of large number of television networks, bandwidth allocations in VHF band was not adequate. More bands were therefore allocated in UHF bands for television broadcasting. The band 470 to 862 MHz, which is also called UHF band IV and V, widely used by the terrestrial television networks all over the world for analog television broadcasting. By virtue of its excellent propagation characteristics, it is the most suitable band for line-of-sight terrestrial transmission. It should be noted that the terrestrial television is not only the sole user of this band. According to ITU frequency allocation register, frequency band 470 to 862 MHz could also be used for following services.

470 – 585 MHz	Fixed & Mobile Communication and Broadcasting
585 – 610 MHz	Fixed and Mobile Communication, Broadcasting and Radio Navigation
610 – 890 MHz	Fixed, Astronomy and Mobile Communication

Currently there are 48 television channels assigned within 470 – 862 MHz band, popularly known as UHF band – IV and V. Each channel is spaced at 8 MHz, as required for normal PAL-B/G transmission and designated as Ch-21 through Ch-69. In Nepal most of this band is still vacant.

3.2 Importance of 700 MHz band

The 700 MHz frequency band is generally referred to as the band that falls in between 698 to 806 MHz. According to ITU classification for Region - I and III, this band could be utilized for both fixed as well as mobile communication. As indicated by GSM Association, an LTE network at 700 MHz would be as much as 70% cheaper to deploy than at 2.1 GHz. In comparison to 2.6 GHz band path loss in 700 MHz band is 26.5dB lower, building penetration losses improves about 3dB and the Doppler shift is better than 10dB.

It is claimed that two to three times as many less sites is required for initial coverage at 700 MHz compared to those in 2.1 or 2.6 GHz. Therefore improved capability and reduced capital expenditure make deployment of radio facilities in UHF band in rural or high-cost regions economically very viable and attractive.

At the most recent World Radio Conference held in 2007, WRC-07, revisions were made by ITU member States to include the range 790 to 960 MHz, for the Region I and III, exclusively for International Mobile Telecommunication (IMT). It was realized that in most of the countries, the upper UHF frequencies above channel-60 are not utilized for television broadcasting. Therefore, a number of countries, including Bangladesh, China, Korea, India, Japan, New Zealand, Papua New Guinea, Philippines and Singapore, voiced that they would use an extra band from 698 to 790 MHz for the implementation of IMT in their countries. It was supported by many countries in the region. Therefore, most of the countries in Region I and III have supported and have been assigning frequencies in 698 to 960 MHz for IMT. In Nepal NTA has already allocated the frequencies from 824 to 960 MHz for mobile communication. Frequencies in the band 698 to 824 are still not assigned. Therefore, it is high time for the Government to block this very precious 700 MHz band for future “IMT-Advance” operations.

3.3 Digital dividend

Due to fast growth in mobile communication, every country in the world has been experiencing acute shortage of frequencies for further expansion of mobile telephony and broadband wireless access. Due to the nature of transmission and bandwidth required for such services, not all frequency bands are suitable in terms of capital expenditure and their transmission capabilities. The lower UHF frequency band from 470 to 862 MHz, which is currently occupied by terrestrial analog television networks and by some other ancillary services, is the most valuable part of frequency spectrum. With the development in digital television technologies, it is now possible to transmit several television channels simultaneously and more efficiently utilizing the same carrier and same bandwidth of 8MHz. Following is a comparative chart showing number of channels that could be broadcast simultaneously using DTT.

Table 1: Comparative Chart

Compression	DVB-T		DVB-T2	
	SDTV	HDTV	SDTV	HDTV
MPEG-2	8	1	10	2
MPEG-4	16	3	20	4

SDTV with 3.5 Mbits/sec coding and MPEG-2 Compression

From the above comparative table it is clear that up to 20 television channels could be simultaneously transmitted using the same carrier and bandwidth in standard definition mode using the second generation DTT technology DVB-T2, along with MPEG-4 compression. The standard definition (SD) is the technology currently being used in analog television in Nepal. Therefore, using an extra Set Top Box (STB) the existing analog TV sets could be used for DTT reception as well. Hence transitioning from analog to DTT would not require changing the television set. This has given hope of freeing up a large portion of frequency in UHF band.

The “Digital Dividend” is a term used by the world community to describe the spectrum freed up as a result of the switchover from analog to digital television. A large portion of spectrum could be freed up if DTT are planned in Single Frequency Network (SFN). Such a system is suitable for television networks where service is provided solely by the Government. In the countries where commercial terrestrial television stations are allowed SFN may not be viable. In such a case Multi Frequency Network (MFN) system is adopted. In either case a large frequency band could be freed up as result of switchover from analog to DTT. In order to harmonize the world standard most of the countries in region I and III and aiming at freeing up from 698 to 806 MHz. Frequencies from 806 to 960 MHz are already in use for IMT. While the United States and a few EU countries have already replaced their analog transmissions with

DTT, most of the remaining EU countries have agreed to turn off analog television transmission progressively from 2010 onwards with complete switchover by December 2013 or so. It should be noted that most of the other countries have set their transition target date not later than 2017. Therefore, it is anticipated that lots of frequencies will be freed up in future for further expansion of more worthwhile services.

The amount of spectrum to be released in the switchover process depends on several factors, such as:

- Geography and topography of a country,
- Degree of penetration of cable and/or satellite television services,
- Requirements for regional or minority television services, and
- Spectrum usage in neighboring countries.
- Digital television technology being implemented

Therefore, size of digital dividend will vary from region to region, and from country to country.

India, which has over 330 TV channels operating in UHF band, has already initiated freeing-up frequencies through digital dividend. As recommended by TRAI, UHF frequencies from 470 to 582 MHz have been exclusively allocated for terrestrial analog as well as digital TV. Three experimental DTT are currently being operated in Kolkata, Chennai and Mumbai. In addition to that a mobile TV using DVB-H in channel-26 has started in Delhi. Frequencies in 582-698 MHz has been reserved for TV and for some other essential services but not yet distributed. To harmonize with world standard, the band 698-806 MHz has been reserved exclusively for IMT.

In the case of Nepal, digital dividend could be easily achieved as number of terrestrial television stations working in UHF band is limited.

3.4 Status of terrestrial TV broadcasting in SAARC countries

The following table illustrates the status of terrestrial television broadcasting in the SAARC countries. Among the 8 SAARC countries, Afghanistan, Pakistan, Sri Lanka, Bangladesh and Nepal have allowed operation of terrestrial television services by the private parties. In India, Bhutan and Maldives, however, the terrestrial television networks are solely owned and operated by the Government or managed by public enterprises only. It is interesting to note that a war-torn country like Afghanistan has liberalized the broadcasting policy by allowing private parties to own and operate terrestrial television in the country. Nearly a dozen private companies operate nationwide commercial terrestrial television stations in Afghanistan. Sri Lanka, on the other hand has most private terrestrial network amongst all SAARC countries. India has been operating 330 Television transmitters within 470 – 582 MHz band.

Table 2: Terrestrial Television in SAARC Countries

S.No.	Countries	Stations	Category	Ownership	Frequencies
1	Afghanistan	1. ANTV, Balkh RTA 2. ATN, Ayna, Tolo, Lemar, Shamshad, Noorin, Ariana, Noor, Arjoo, Setara	National Local/National	State-owned Private	VHF VHF/UHF
2	Bangladesh	1. BTV 2. Ekushey TV	National Local in Dhaka	State-owned Private	VHF Not specified
3	Bhutan	Bhutan Broadcasting Service (BBS)	National	State-owned	VHF
4	India	Doordarshan (DD). Total of 1440 transmitters	National	State-owned	VHF/UHF 470-582 MHz
5	Maldives	TV Maldives (TVM) and TVM Plus	National	State-owned	VHF
6	Nepal	1. NTV and NTV Plus 2. Image Channel, KTV and a few low powered	National Local/National	State-owned Private	VHF/UHF 470-540MHz
7	Pakistan	1. PTV 2. Aaj TV (ATV)	National National	State-owned Private	VHF/UHF Not specified
8	Sri Lanka	1. ITN, Rupavahini, Nethra and Channel Eye 2. Sirasa, MTV, TNL, ETV, Swarnavahini, ART, Shakthi, TV lanka, Derana, Max TV, TV2	National Local/National	State-owned Private	VHF UHF

Source: World Radio/TV Handbook, 2010 and Internet

3.5 Digital Terrestrial Television (DTT) systems

Several DTT systems exist worldwide. Some of them are indicated below.

- ATSC (Advanced Television Systems Committee) is the digital television standard developed in the USA. ATSC transmits with MPEG-2 video and audio compression. It produces wide screen 16:9 images up to 1920x1080 pixels in size. Up to 6 SDTV channels can be broadcast from a single TV transmitter using an existing 6 MHz channel bandwidth. ATSC uses Dolby Digital AC-3 format to provide 5.1 channel surround sound. Numerous auxiliary services can also be provided in this system including radio programmes.
- DVB-T (Digital Terrestrial Multimedia Broadcast) is the standard of European DVB consortium for the transmission of digital terrestrial television. This system transmits a compressed digital audio/video stream using concentrated channel coding modulation technique, COFDM with either 64 or 16 state QAM. The source coding method is MPEG-2 and MPEG-4. Several radio and television programmes can be transmitted and controlled using this technology.
- DMB-T (Digital Multimedia Broadcast -T) is the DTT standard of China. It is a fusion of TDS-OFDM, which is similar to DVB-T, and ADTB-T, developed by Shanghai University.
- ISDB-T (Integrated Services Digital Broadcasting – Terrestrial) was developed in Japan and works similar to DVB-T. It uses COFDM modulation with PSK/QAM. The compression system is MPEG-2. ISDB-T can also transmit radio programmes in addition to TV channels. SBTVD (Sistema Brasileiro de Televisao Digital) was developed in Brazil. It is a version of ISDB-T with MPEG-4 compression.
- T-DMB (Terrestrial Digital Multimedia Broadcast) is a standard, that was developed in the Republic of Korea.

Countries utilizing various DTT systems worldwide are indicated in the following illustration. From the illustration it is evident that most of the countries in the world, including whole of Europe, Australia, Africa and South-east and Southern Asian countries are using DVB-T. In the SAARC countries, India, Bangladesh and Sri Lanka have either implemented or currently testing DTT based on DVB-T or DVB-T2. Sri Lanka's Dialog Telecom introduced DTT in Colombo utilizing DVB-T in January 2008. Recently, Sri Lanka's Mass Media and Information Ministry has announced that they would introduce DTT throughout the country through its State-owned Sri Lanka Rupavahini Corporation (SLRC) and Independent Television Network (ITN) by 2017. In India DTT is being tested by its state owned Doordarshan in three metropolitan cities. Besides DTT, India has also launched Mobile Television, commonly referred to as DVB-H in some metropolis. Bangladesh has adopted DVB-T and is in the process of initiating test transmission in Dhaka during this year.

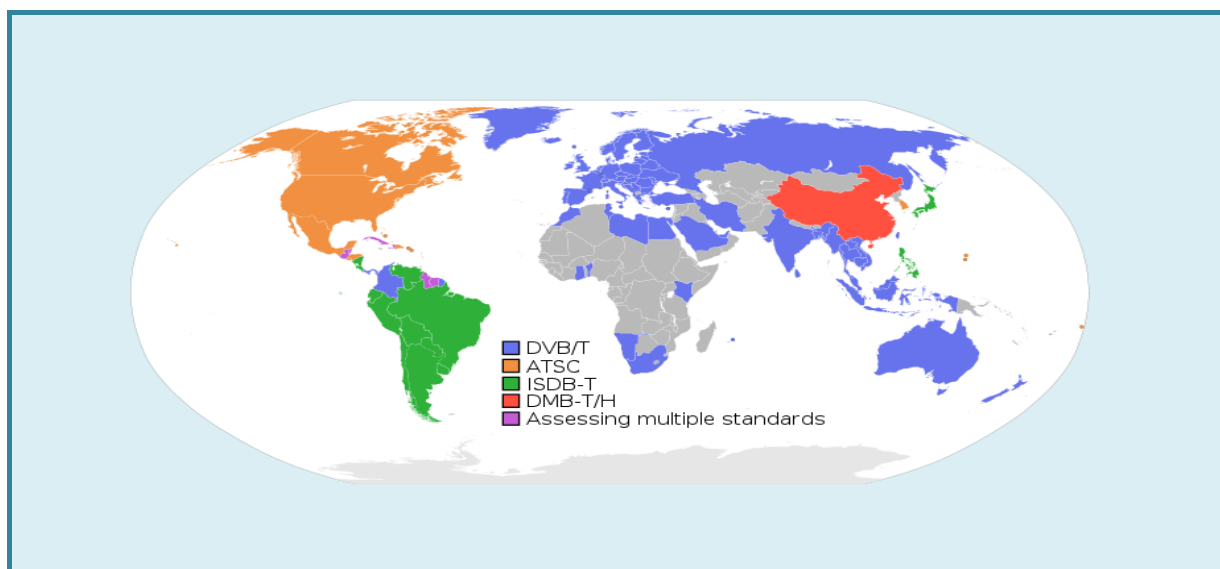

Table 3: Implementation of DTT in some selected countries

Countries	System Adopted	Trial Year	Analog Switch Off
Afghanistan	Not decided	Not decided	Not decided
Australia	DVB-T	1998	2012/13
Bangladesh	DVB-T	2010	Not Fixed
Bhutan	Not decided	Not decided	Not decided
Cambodia	DVB-T	2007	2015
Canada	ATSC	1997	2011
China	DMB-T	2005	2015/18
EU Countries, UK	DVB-T	1999	Some already implemented Complete Transition by 2012
Hong Kong	DMB-T	2006	2012
India	DVB-T	2000	Not Fixed
Indonesia	DVB-T	2007	2015
Japan	ISDB-T	2003	2011/1
Laos	VB-T	2007	2015
Malaysia	DVB-T	2006	2015
Maldives	Not decided	Not decided	Not decided

Countries	System Adopted	Trial Year	Analog Switch Off
Nepal	Not decided	Not decided	Not decided
New Zealand	DVB-T	2008	2012/13
Pakistan	Not decided	Not decided	Not decided
Philippines	ISDB-T	2007	2015
Singapore	DVB-T	1999	2017
South Korea	ATSC	1997	2012
Sri Lanka	DVB-T	2008	2017
Thailand	DVB-T	2007	2015
USA	ATSC	1996	Implemented in 2009

Source: www.dtvstatus.net

4 Worldwide trends in utilization of 2.6 GHz band

The 2.6 GHz band, which is also referred to as 2.5 GHz band in some countries (Brazil, USA, Singapore, etc.), covers the range from 2500 to 2690 MHz. This band was identified as suitable for terrestrial mobile communication during the World Radio Communication Conference in 2000 (WRC-2000). Other applications of this band, which vary from country to country, include satellite services, fixed and mobile communication and terrestrial video broadcasting using Multichannel Multipoint Distribution System (MMDS). In many countries frequencies in this band are occupied by commercial as well as non-commercial entity like military and ISPs. Therefore, during WRC-2000 questions arose about the conditions under which interference could be avoided between commercial mobile communications and existing services occupied by other organizations. This issue was further discussed during WRC-07 with a decision to remove all satellite operation from this band and to implement stringent measures to minimize the interference from other users. It was unanimously agreed by all countries to ensure fair and smooth transitions in clearing-up currently occupied frequencies by other users in favor of economically more valuable commercial mobile communication networks. Therefore, 2.6 GHz band has been earmarked and more often referred to as "IMT-2000 expansion band". However, controversy surrounded between paired and un-paired spectrum suited for FDD and TDD modes of operations. Therefore, WRC-2000 defined three options under "Recommendation ITU-R, M.1036-3" to chose from.

Table 4: ITU Options for 2.6 GHz Band

Frequency Arrangements	Mobile Tx UL (MHz)	Centre Gap (MHz)	BTS Tx. DL (MHz)	Duplex Separation (MHz)	Centre Gap Usage
Option-1	2500-2570	50	2620-2690	120	TDD
Option-2	2500-2570	50	2620-2690	120	FDD DL (outside 2.6 GHz band)
Option-3	Leave entire band flexible for FDD or TDD				

- **ITU option-1** defines clearly the paired and unpaired spectrum in a standardized configuration. It is formulated to avoid interference problem between FDD and TDD modes of operation.
- **ITU Option-2** does not include unpaired (TDD) spectrum. Instead of that, the central gap of 50 MHz has been proposed to use as a downlink for a pair outside 2.6 GHz band.
- **ITU Option-3** allows freedom of choice to the countries leaving entire band flexible for FDD or TDD.

Option-2 does not look very practical as centre gap of 50 MHz has been proposed to pair with unknown frequencies outside 2.6 GHz band. Option-3 on the other hand is also not very clear and cannot be harmonized with the manufacturers since countries are allowed to decide on TDD or FDD at their will. Therefore, most of the countries in Europe and Asia have opted for Option-1, which is clearly defined and more practical. Licenses have been issued in several countries, notably in Norway, Sweden, Finland, Singapore, Hong Kong and the United States. More countries are about to auction within this year or so.

It should be noted that in all mobile frequency bands, demands for paired spectrum is more than unpaired. There is greater interest in paired spectrum in 2.6 GHz band among established cellular operators. This is because it would facilitate them with backward compatibility with existing FDD systems through least expensive terminals. Therefore ITU Option-1 is well suited to meeting this goal of any operator by enabling them technology neutrality and competitive 4G wireless equipment choices for both FDD and TDD for both LTE and WiMAX.

Global 2.6 GHz licensing experience

Between 2005 to 2009 Sweden, Norway, Finland, USA and Hong Kong have successfully auctioned frequencies in 2.6 GHz band. During this year a number of European countries are planning to auction the paired and unpaired frequencies in this band. It is worth noting that most of the countries, if not all, have opted for ITU Option-1, whereas auctioned bandwidths varied from country to country. Option-1 provides a harmonized band plan and has received global recognition among the service providers as well as the equipment/device vendors. Therefore choosing Option-1 is in favour of the regulators to yield more benefits through auctioning. Therefore, keeping “technology neutral” policy Nepal should also adopt ITU Option-1 for its future allocations in 2.6 GHz band.

5 Existing scenario in Nepal

5.1 Terrestrial TV broadcasting

Nepal Television (NTV) is only Government entity that provides terrestrial television broadcasting across the country. It was established by the Government under the Sixth National Five-year Development Plan in January 1985 (BS 2041) with a view to enhancing country’s socio economic development. NTV uses both VHF and UHF bands for terrestrial transmission and provides nation-wide terrestrial network. It claims to have been providing 42% coverage within Nepal. Besides NTV, UHF band is also being used for Terrestrial TV Transmission by private broadcasting companies, like, Kantipur Television, Image Channel and several other local TV Broadcasting stations outside the Kathmandu valley. All stations provide services in analog PAL-B/G mode. List of frequencies currently being utilized by various terrestrial television stations within Nepal are indicated below.

Table 5: List of Terrestrial TV Stations in Nepal

S.N.	Channel No	Channel Limit (MHz)	Vision Carrier (MHz)	Sound Carrier (MHz)	Organization, Place	Tx. Power
1.	5	174.00-181.00	175.25	180.75	NTV, Phulchowki, Kathmandu	5KW
2.					NTV Plus, Phulchowki, Kathmandu	5KW
3.	5	174.00-181.00	175.25	180.75	NTV Chamere Danda, Surkhet	1KW
4.	7	188.00-195.00	189.25	194.75	NTV Relay, Sarangkot, Pokhara	200W
5.	11	216.00-223.00	217.25	222.75	NTV Relay, Jaleshwar	2KW
6.	5	174.00-181.00	175.25	180.75	NTV Relay, Namje, Dhankutta	2KW
7.	12	223.00-230.00	224.25	229.75	NTV Relay, Ilam	5KW
8.	12	223.00-230.00	224.25	229.75	NTV Relay, Daunne	500W

S.N.	Channel No	Channel Limit (MHz)	Vision Carrier (MHz)	Sound Carrier (MHz)	Organization, Place	Tx. Power
9.	5	174.00-181.00	175.25	180.75	NTV Relay, Tansen, Palpa	200W
10.	4	61.00-68.00	62.25	67.75	NTV Relay, Hetauda	100W
11	7	188.00-195.00	189.25	194.75	NV Relay, Butwal	10W
12	21	470.00-478.00	471.25	476.75	NTV Plus, Kathmandu	1 KW
13	22	478.00-486.00	479.25	484.75	Lumbini community, Lumbini	500W
14	23	486.00-494.00	487.25	492.75	Kantipur Television, Lalitpur	5KW
15	23	486.00-494.00	487.25	492.75	Kantipur Television, Namje, Dhankutta	5KW
16	23	486.00-494.00	487.25	492.75	Himshikhar TV, Damak	500W
17	23	486.00-494.00	487.25	492.75	Golden Eye TV, Pokhara	500W
18	24	494.00-502.00	495.25	500.75	Shantika lagi sanchar, Rupandehi	500W
19	24	494.00-502.00	495.25	500.75	Team Television, Makwanpur	500W
20	25	502.00-510.00	503.25	508.75	Image Channel, Kathmandu	1 KW
21	25	502.00-510.00	503.25	508.75	Makalu Media, Sunsari	100W
22	26	510.00-518.00	511.25	516.75	Bikas ra Sanchar samaj, Birjung	500W
23	27	518.00-526.00	519.25	524.75	Paryawaran TV Nepal, Lalitpur	500W
24	27	518.00-526.00	519.25	524.75	Kalash Television, Chitwan	500W
25	28	526.00-534.00	527.25	532.75	A.R Television, Kathmandu	100W
26	29	534.00-542.00	535.25	540.75	Crystal Sanchar, Chitwan	500W
27	29	534.00-542.00	535.25	540.75	Voice of Youth, Kathmandu	500W

Source: MOIC and NTV

5.2 Current licensing regime and broadcasting regulations

Current Licensing Regime in broadcasting in Nepal is governed by "National Broadcasting Act, 2049" and the corresponding "National Broadcasting Regulations, 2052" and amendments, as may be published time-to-time. The latest amendment to these regulations was proposed as "National Broadcasting Regulations, 2067 (Fifth Amendment), which has made various provisions with regard to distribution of programs through cable and DTH networks. However, this Amendment is yet to be approved.

Due to current free licensing regime in Nepal, any organization or person willing to establish a terrestrial television channel may get the broadcasting license freely without having any obligatory restrictions on whether or not such a broadcast could be sent through cable networks or not. This has inspired many operators in the recent years to acquire low power TV licenses and get the programs sent through cable networks instead of improving terrestrial radio broadcasting capability. When such a license is granted MOIC has to allocate, as usual, 8 MHz of UHF spectrum for each channel at a very small fee. Consequently, this precious UHF band is getting exhausted rapidly. If not controlled in time, Nepal will have no spectrum left in this precious band for the forthcoming next generation technologies. It is believed that such a practice could be effectively eliminated if licenses are also granted for cable broadcasting. Since issue of spectrum is not involved, this would help saving of precious radio frequencies in long run.

Due to propagation quality, UHF band has always been considered as a very precious and most revenue generating frequency spectrum. 700 MHz band (698-806 MHz) falls within the terrestrial television band, which is harmonized worldwide for the future expansion of fourth generation wireless broadband technologies. This band is of interest to all leading manufacturers and operators for expansion of LTE and WiMAX technologies. Several countries have either auctioned or they are in the process of auctioning chunks of this band for millions of dollars. In such circumstances, a regulatory framework for controlling

this band for further distribution for analog television, point-to-point radio communication, radio links, etc. must be initiated as soon as possible.

6 Recommendations

⇒ RECOMMENDATION #1

Band Plan and allocation of UHF Frequencies

It is recommended to allocate the UHF frequency band 470 – 862 MHz as tabulated hereunder. This is in line with current MOIC planning.

Similarly, it is the duty of the Government to allocate some band exclusively for Public Protection and Disaster Relief activities (PPDR). In this regard, it should be noted that the frequency band 806 to 824 is harmonized worldwide for PPDR. It is therefore suggested to allocate frequencies for various users as follows:

Table 6: Current and Proposed Assignment

Channel No.	Channel Limit (MHz)	Vision Carrier (MHz)	Sound Carrier (MHz)	Allocations
21 -29	470.00-542.00			Assignments to terrestrial analog TV
30	542.00-550.00	543.25	548.75	Further assignments for terrestrial Television (DTT only)
31	550.00-558.001	551.25	556.75	
32	558.00-566.00	559.25	564.75	
33	566.00-574.00	567.25	572.75	
34	574.00-582.00	575.25	580.75	
35	582.00-590.00	583.25	588.75	
36	590.00-598.00	591.25	596.75	
37	598.00-606.00	599.25	604.75	
38	606.00-614.00			Radio Astronomy
39 - 48	614.00-698.00	615.25	620.75	Fixed/Mobile/Broadcasting (On Priority basis)
	698.00-806.00	700 MHz Band		For Future IMT use only (Technology Neutral Assignments)
	806.00-824.00			Public Protection & Disaster Relief (PPDR) as recommended by WRC-03
	824.00-862			Already assigned for CDMA Operations

Source: MOIC and WRC-03 Documents

⇒ RECOMMENDATION #2

Transition to Digital Television

Countries around world have been gradually transiting to DTT with a view to vacating some of the frequencies in the precious UHF band and to keep in pace with better technology in digital audio-visual transmission. DTT is not only very efficient but also superior in terms of efficient channel utilization and picture clarity compared to its current counterpart analog TV broadcasting. Several systems exist worldwide, out of which DVB-T is the most used technology covering entire Europe, Middle East, South

East Asian countries, Australia, New Zealand, almost all African countries and SAARC countries. Our current analog TV transmission is PAL-B/G, which is also adopted by the abovementioned countries. Therefore, in order to concur with and to remain within regional standardization, Nepal should officially make a declaration to adopt DVB-T as its officially approved standard in Nepal. This is the first generation technology in digital broadcasting. Recently the second generation digital transmission DVB-T2 also has been developed that is said to be 40% more efficient than its predecessor DVB-T and also backward compatible with DVB-T. STBs for DVB-T2 is also getting cheaper day-by-day. While the entire Western countries will make complete transition from analog to DTT by 2012/2013, it is envisaged that all other countries will also transit by 2017. Therefore, it is high time for Nepal to make a transition target. The committee recommends adopting DVB-T technology, which is in line with most of the countries in our region. Since DVB-T2, is also now available, there should not be any restrictions imposed on newer generation DVB technologies so long as they are backward compatible. The committee suggests adopting this target as follows:

Table 7: DTT Transition Plan

	Particulars	Target Date
1.	Declare DVB-T, or its successors as the national standard for DTT in Nepal	June 2011
2.	Prepare and implement Govt. Regulations for transition to DTT	December 2011
3.	Set target date for complete transition from Analog to DTT	December 2017

⇒ **RECOMMENDATION #3**

Licensing Framework on Terrestrial TV Broadcasting

Current National Broadcasting Regulation, 2052 is based on Section 29 of the National Broadcasting Act, 2049. The equipment procurement is governed by Radio Communication Licensing Regulations, 2049, formulated pursuant to Radio Act, 2014. The proposed Fifth Amendment to National Broadcasting Regulation, 2052, issued in 2067, specifies various definitions of the service providers and new fee structures for terrestrial television transmission. This Amendment is yet to be approved. It is worth noting that in the prevailing regulations no clear provisions are made for DTT broadcasting for distribution of their programs through cable networks. Due to the above fact and also due to the licensing regime being free in the country, the precious UHF frequency band is getting exhausted quickly in the recent years. Therefore, some of the regulations must be added and/or amended, as appropriate, to discourage unnecessary hoarding of the frequencies and unauthorized distribution through other networks. While amendments to these regulations should be made carefully and in more professional manner, the committee suggests the following for consideration.

- a) Terrestrial Television Stations should be classified as
- Institutional Station
 - Local Station, and
 - National Station

Institutional Stations shall be confined within a very small area (max within 1-2 Km diameter) and shall be licensed to prestigious institutions only; like University, Large Factories, etc. Such stations shall serve within the campus or factory areas only by providing information/entertainment within the premises. Institutional stations shall have no right to distribute through cable networks or DTH. Maximum power output recommended is 5 Watts.

Local Stations shall serve the areas not exceeding 100 Km diameter. Such stations shall be operated to serve the metropolitan areas or large rural community. License shall be granted to Government, private sector as well as community based organizations. All local stations shall be confined within their permitted areas of broadcast and shall not be allowed to distribute its signals through cable or DTH in

order to avoid reaching beyond its jurisdiction. Maximum power recommended is up to 10 KW, which must be justified through field strength calculations.

National Stations shall have right to expand its services throughout the country. Such licenses should be granted to Government/Public or Private/Commercial institutions. There should be no power output limitation so long as a particular station justifies the field strength calculations in the target areas. Since the license has been obtained for the entire country, national stations shall be allowed to distribute its signal through cable or DTH.

b) Frequency allocations

For analog transmission frequencies shall be confined within 472- 542 MHz. Frequencies shall be allocated and reused depending on geographical locations. There are all together 9 channels within this band. (In India as many as 330 TV stations are working within 14 channels (470-582 MHz) by reusing them).

During transition from analog to DTT parallel transmissions shall be allowed from 542 to 606 MHz. There are all together 8 channels available within this band. For Local and National Stations minimum infrastructure required for quality broadcasting must be adhered to which shall be defined by MOIC as obligatory. This will include, minimum required manpower, investments on technologies, studio, safety requirements and training, etc.

c) Broadcasting License through Cable

Apart from terrestrial radio transmission, provisions should also be made to provide separate licenses to broadcast through cable networks. Since there is no frequency spectrum involved, this would benefit through savings of precious spectrum for other uses. Broadcasting Licenses through cable in turn should be classified as:

- Local, and
- National

The licensee should be confined to broadcast within their areas of jurisdiction.

⇒ **RECOMMENDATION #4**

Allocation of Frequencies in 700 MHz Band

In most of the countries the 700 MHz band (698 -806 MHz) is still being occupied by various users for different purposes. Only in the United States this band has been completely freed-up through digital dividend. In the US channel planning has been made and some of the frequencies have already been auctioned for FDD and TDD operations. As most of the countries are still in the process of vacating and preparing channel utilization plan, the leading manufacturers as well as the service providers are in the wait and see mood prior to making any decision on deployment of mobile or broadband services. In Nepal, fortunately this band is still vacant. Therefore, it is highly recommended that no spectrum is issued for the time being for any traditional services until potential benefits of this band become clear. For future reference US band planning has been described below:

US 700 MHz Band Plan

The spectrum being vacated due to this digital TV transition has been allocated for deployment of IMT applications, Mobile TV and Public Safety services. Under this new band plan, the 700 MHz band is divided into two sub bands:

- Lower band – 698-746 MHz
- Upper band – 746 -793 MHz.

Duplex separation of FDD spectrum is kept at 30 MHz. To avoid frequency interference the BTS TX of both bands have been kept closer to each other.

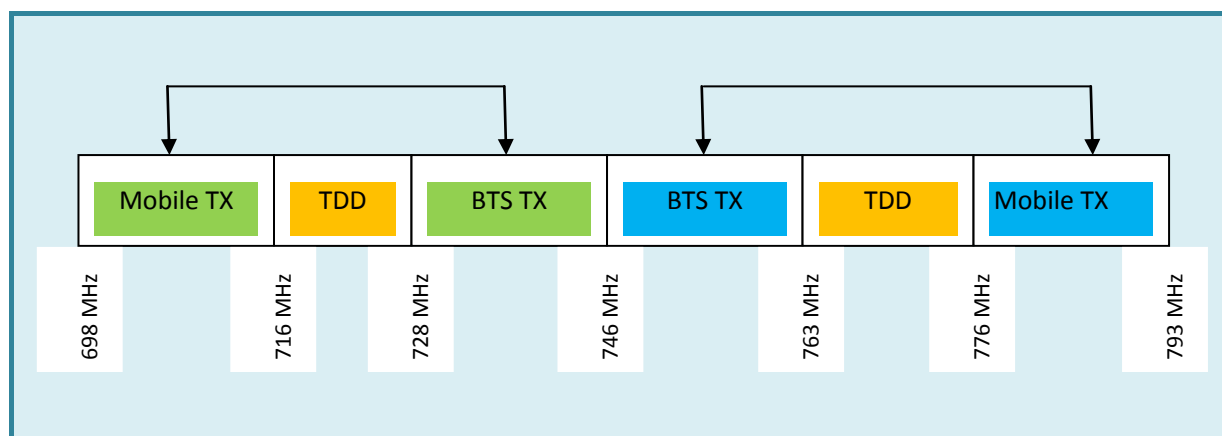

All together 95 MHz bandwidth has been utilized in the following manner:

Lower Band: 2x18 MHz for FDD and 1x12 MHz for TDD

Upper Band: 2x17 MHz for FDD and 1x13 MHz for TDD

Therefore bandwidth for FDD is 2x35 MHz and for TDD 1x25 MHz.

It is worth noting that no country in this region, including India, has made any 700 MHz band plan yet.

⇒ **RECOMMENDATION # 5**

Allocation of Frequencies in 2.6 GHz Band

Looking at the global importance of this band and the tremendous amount of royalty that it could generate for more promising 4G telecommunication and broadband services, this band should be vacated immediately and should be allocated to the IMT 2000 and beyond. A band plan has been proposed and presented in tabulated form below. It is a Swedish model and looks appropriate for Nepal too. Keeping in technology neutral policy, it is recommended that the Govt. should auction various slots in the following manner:

Table 8: Proposed Assignments in 2.6GHz Band

Frequencies (MHz)	System	Bandwidth (MHz)	Remarks
2500 – 2505	FDD-1/ UL	5	Auction 8 slots each 2x5 MHz in pair
2505 – 2510	FDD-2/UL	5	
2510 – 2515	FDD-3/UL	5	
2515 – 2520	FDD-4/UL	5	
2520 – 2525	FDD-5/UL	5	
2525 – 2530	FDD-6/UL	5	
2530 – 2535	FDD-7/UL	5	
2535 – 2540	FDD-8/UL	5	
2540 – 2545	FDD-9/UL	5	Reserve 6 slot, each 2x5 MHz in pair
2545 – 2550	FDD-10/UL	5	
2550 – 2555	FDD-11/UL	5	
2555 – 2560	FDD-12/UL	5	
2560 – 2565	FDD-13/UL	5	

Frequencies (MHz)	System	Bandwidth (MHz)	Remarks
2565 – 2570	FDD-14/UL	5	
2570 – 2595	TDD	25	Auction 2 slots each 25 MHz for TDD
2595 – 2620	TDD	25	
2620 – 2625	FDD-1/DL	5	Auction 8 slots each 2x5 MHz in pair
2625 – 2630	FDD-2/DL	5	
2630 – 2635	FDD-3/DL	5	
2635 – 2640	FDD-4/DL	5	
2640 – 2645	FDD-5/DL	5	
2645 – 2650	FDD-6/DL	5	
2650 – 2655	FDD-7/DL	5	
2655 – 2660	FDD-8/DL	5	
2660 – 2665	FDD-9/DL	5	Reserve 6 slot, each 2x5 MHz in pair
2665 – 2670	FDD-10/DL	5	
2670 – 2675	FDD-11/DL	5	
2675 – 2680	FDD-12/DL	5	
2680 – 2685	FDD-13/DL	5	
2685 – 2690	FDD-14/DL	5	

There are 14 paired slots for FDD operation, each 2x5 MHz. It is recommended to auction 2x5 slots at a time pending further auction depending upon deployment success. For TDD operation 50 MHz is available in the band 2570 – 2620 MHz. It is recommended to assign 2x25 MHz each for up to 2 operators maximum. Since some of the frequencies in this band are still being assigned to various organizations on temporary basis, it is suggested that MOIC takes appropriate action to vacate the band prior to implanting this band plan.

Annex IV

Details of channels: power of operation of TV channels in Nepal⁴

List of Terrestrial TV Stations in Nepal

S.N	Channel No	Channel Limit (Mhz)	Vision Carrier (MHz)	Sound Carrier (MHz)	Organization, Place	Tx. Power
1.	5	174.00-181.00	175.25	180.75	NTV, Phulchowki, Kathmandu	5KW
2.					NTV Plus, Phulchowki, Kathmandu	5KW
3.	5	174.00-181.00	175.25	180.75	NTV Chamere Danda, Surkhet	1KW
4.	7	188.00-195.00	189.25	194.75	NTV Relay, Sarangkot, Pokhara	200W
5.	11	216.00-223.00	217.25	222.75	NTV Relay, Jaleshwar	2KW
6.	5	174.00-181.00	175.25	180.75	NTV Relay, Namje, Dhankutta	2KW
7.	12	223.00-230.00	224.25	229.75	NTV Relay, Ilam	5KW
8.	12	223.00-230.00	224.25	229.75	NTV Relay, Daunne	500W
9.	5	174.00-181.00	175.25	180.75	NTV Relay, Tansen, Palpa	200W
10.	4	61.00-68.00	62.25	67.75	NTV Relay, Hetauda	100W
11.	7	188.00-195.00	189.25	194.75	NV Relay, Butwal	10W
12.	21	470.00-478.00	471.25	476.75	NTV Plus, Kathmandu	1 KW
13.	22	478.00-486.00	479.25	484.75	Lumbini community, Lumbini	500W
14.	23	486.00-494.00	487.25	492.75	Kantipur Television, Lalitpur	5KW
15.	23	486.00-494.00	487.25	492.75	Kantipur Television, Namje, Dhankutta	5KW
16.	23	486.00-494.00	487.25	492.75	Himshikhar TV, Damak	500W
17.	23	486.00-494.00	487.25	492.75	Golden Eye TV, Pokhara	500W
18.	24	494.00-502.00	495.25	500.75	Shantika lagi sanchar, Rupandehi	500W
19.	24	494.00-502.00	495.25	500.75	Team Television, Makwanpur	500W
20.	25	502.00-510.00	503.25	508.75	Image Channel, Kathmandu	1 KW
21.	25	502.00-510.00	503.25	508.75	Makalu Media, Sunsari	100W
22.	26	510.00-518.00	511.25	516.75	Bikas ra Sanchar samaj, Birjung	500W
23.	27	518.00-526.00	519.25	524.75	Paryawaran TV Nepal, Lalitpur	500W
24.	27	518.00-526.00	519.25	524.75	Kalash Television, Chitwan	500W
25.	28	526.00-534.00	527.25	532.75	A.R Television, Kathamandu	100W
26.	29	534.00-542.00	535.25	540.75	Crystal Sanchar, Chitwan	500W
27.	29	534.00-542.00	535.25	540.75	Voice of Youth, Kathmandu	500W

Source: MOIC and NTV

⁴ Some NTV stations are not listed here.



International Telecommunication Union
Telecommunication Development Bureau
Place des Nations
CH-1211 Geneva 20
Switzerland
www.itu.int