



NEPAL NATIONAL BUILDING CODE

NBC 203: 2015



GUIDELINES FOR EARTHQUAKE RESISTANT BUILDING CONSTRUCTION: LOW STRENGTH MASONRY

This publication represents a standard of good practice and therefore takes the form of recommendations. Compliance with it does not confer immunity from relevant legal requirements, including bylaws

नेपाल सरकार (मन्त्रिस्तरीय) को मिति २०७२/१६ को निर्णयानुसार स्वीकृत

Government of Nepal
Ministry of Urban Development
Department of Urban Development and Building Construction
Babar Mahal, Kathmandu, Nepal
2072

This page is intentionally left blank.

TABLE OF CONTENTS

Preface	i
0. Foreword	1
0.1 Introduction	1
0.2 Objective	1
0.3 Background	1
0.4 Applicability	1
0.5 Interpretation	1
0.6 Terminology	2
1 Scope	3
1.1 Type of Buildings Covered	3
1.2 Limitation	3
2 General Requirements for Earthquake Resistance Construction	4
2.1 Proper Site Selection	4
2.2 Appropriate Planning	4
2.3 Good Foundation Resting on a Firm Base	4
2.4 Creating a Box Effect	4
2.5 Better Bonding between Masonry Units	4
2.6 Controlled Size and Location of Openings	5
2.7 Light Construction	5
3 Materials	6
3.1 Boulder Stones	6
3.2 Quarry Stones	6
3.3 Dressed Stones	6
3.4 Stabilized Soil Block	6
3.5 Brick	6
3.6 Mud Mortar	6
3.7 Bamboo	6
3.8 Timber	7
3.9 Reinforced concrete	7
4 Site Consideration	8
4.1 General	8
4.2 Site Selection	8
4.2.1 Geological Fault or Ruptured Areas	8
4.2.2 Areas Susceptible to Landslide	8
4.2.3 Boulder Hazard	8
4.2.4 River Bank	8
4.2.5 Swamp/Marshy Area	8
4.2.6 Steep Slope	9
4.2.7 Water-Logged Area	8
4.2.8 Filled Area	9
4.3 Site Investigation	9
4.4 Classification of Soil Type	9

5	Planning	11
5.1	Shape	12
5.2	Proportion.....	12
5.3	Storey Height	12
5.4	Number of Storey.....	12
5.5	Plinth Level	12
6	Foundation	13
6.1	General	13
6.2	Strip Footing.....	13
6.3	Masonry for Foundation	15
6.4	Foundations on Sloping Site	15
7	Wall.....	17
7.1	General	17
7.2	Wall Thickness.....	18
7.3	Unsupported Wall Length.....	19
7.4	Height of Walls	19
8	Openings in Walls.....	20
8.1	Maximum Combined Width of Openings	21
8.2	Position of Openings.....	21
9	Floors and Roofs	22
9.1	Structure	22
9.1.1	Posts and Capitals	22
9.1.2	Beams and Bearings.....	26
9.1.3	Wall Plates	28
9.1.4	Joists and Rafters	30
9.2	Floor Finishing and Roof Covering	31
9.2.1	Bridging Materials	31
9.2.2	Floor Finishing.....	33
9.2.3	Roof Covering.....	33
9.2.3.1	Mud	33
9.2.3.2	Thatch.....	33
9.2.3.3	Stone Slabs	35
9.2.3.4	MCR Tiles.....	35
9.2.3.5	Clay Tiles	36
9.2.3.6	CGI Sheets	37
9.3	Bamboo for Flooring and Roofing	37
9.3.1	Bamboo Flooring	37
9.3.2	Bamboo Roofing.....	39
10	Seismic Resistant Components.....	42
10.1	Vertical Reinforcement.....	43
10.1.1	Bamboo	43
10.1.2	Timber.....	45
10.1.3	Steel.....	47
10.2	Horizontal Bands.....	51
10.2.1	Bamboo Band	52
10.2.2	Timber Band	54
10.2.3	Reinforced Concrete Band.....	56
10.3	Dowels at corners and junctions	59

10.4	Gable Band.....	61
10.5	Diagonal Bracing.....	62
10.6	Lateral Restrainers	63
11	Miscellaneous	64
11.1	Damp Proof Course.....	64
11.2	Drainage	65
11.3	Plastering.....	66
APPENDIX -1 HARVESTING AND PRESERVING BAMBOO FOR CONSTRUCTION.....67		

1	Harvesting and Preservative Treatment.....	67
1.1	Harvesting	67
1.1.1	Harvesting Guidelines.....	67
1.1.2	Clump Cure.....	67
1.2	Preservative Treatment	67
1.2.1	Water Leaching	68
1.2.2	White Wash and Other Coatings	68
1.2.3	Brushing, Swabbing, Spraying and Dipping	68
1.3	Fire Retardant Treatment	69
1.4	Storage.....	69

APPENDIX - 2 FIRE-RETARDANT TREATMENT FOR THATCH ROOF..... 71

1	General	71
1.1	Materials Required.....	71
1.2	Method of Preparation	71
1.2.1	Preparation of Stabilised Mud Mortar	71
1.2.2	Preparation of Bitumen cut back ₁ (for NEM).....	71
1.2.3	Preparation of NEM mortar	72
1.2.4	Preparation of Bitumen cut back ₂ for Stabilised Mud Slurry.....	72
1.2.5	Preparation of Stabilised Mud Slurry ₁ for NEM.....	72
1.2.6	Preparation of Stabilised Mud Slurry ₂ for Fire Retardant Plaster	72
1.3	Method of Application	73
1.3.1	Dressing of Roof Surface.....	73
1.3.2	Application of Stabilised Mud Plaster	73
1.3.3	Application of Stabilised Mud Slurry ₁	73
1.3.4	Application of NEM Plaster	73
1.3.5	Application of Stabilised Mud Slurry ₂	73

APPENDIX - 3 REFERENCE MATERIALS

APPENDIX - 4 GLOSSARY

LIST OF FIGURES

Figure 5.1 :	Recommended forms of buildings	11
Figure 6.1 :	Details of Strip Footing Masonry Foundation	13
Figure 6.2 :	Details of Strip Footing Masonry Foundation	14
Figure 6.3 :	Foundation on Sloping Land	16
Figure 7.1(A) :	Details of Wall Construction (Stone Masonry)	17
Figure 7.1(B) :	Details of Wall Construction (Brick Masonry)	18
Figure 7.2 :	Buttress on walls	19
Figure 8.1 :	Location of Openings	20
Figure 9.1 :	Details of Fixing Posts on Base Pad	23
Figure 9.2 :	Details of Fixing of a Series of Posts on Base Strip	24
Figure 9.3 :	Details of Fixing Capitals on the Posts	25
Figure 9.4 :	Alternative Details of Fixing Struts on Posts and Beams	25
Figure 9.5(A) :	Details of Fixing Keys on Beams	26
Figure 9.5(B) :	Details of Wire Binding of Beams to Bands	27
Figure 9.6(A) :	Details of Fixing Wall Plates	28
Figure 9.6(B) :	Details of Fixing Wall Plates	29
Figure 9.7(A) :	Details of Fixing Joists and Rafters	30
Figure 9.7(B) :	Details of Fixing Joists and Rafters	31
Figure 9.8 :	Details of Fixing Bridging Materials to Joists and Rafters	32
Figure 9.9 :	Details of Improved Mud Roofing	33
Figure 9.10 :	Details of Improved Thatch Roofing	34
Figure 9.11 :	Details of Anchoring Stone Slabs	35
Figure 9.12 :	Details of Fixing MCR Tiles	36
Figure 9.13 :	Details of Fixing Clay Tiles	37
Figure 9.14 :	Details of Fixing CGI Sheets	37
Figure 9.15 :	Details of Bamboo Flooring	38
Figure 9.16 :	Details of Simple Bamboo Roofing	39
Figure 9.17 :	Details of Trussed Bamboo Roofing	41
Figure 9.18 :	Details of Wooden Roof Trusses	42
Figure 10.1 :	An Overall View of a building with Seismic-Resistant Components	42
Figure 10.2 :	Bamboo as Vertical Reinforcement	45
Figure 10.3 :	Timber as Vertical Reinforcement	45
Figure 10.4(A) :	Steel for Vertical Reinforcement	48
Figure 10.4(B) :	Vertical Reinforcement in Rubble Stone masonry	49
Figure 10.4(C) :	'Through' Stone or Bond Elements in Stone Walls in Mud Mortar	50
Figure 10.5(A) :	Bamboo for Horizontal Band	52
Figure 10.5(B) :	Bamboo for Horizontal Band	53
Figure 10.6(A) :	Timber for Horizontal Band	54
Figure 10.6(B) :	Details of Timber Reinforcing at Corners and T-Junctions	55
Figure 10.7 (A) :	Details of reinforcement in R.C. band	58
Figure 10.7 (B) :	Details of reinforcement in R.C. band	59
Figure 10.8 :	Corner and Junction Strengthening by Placing Dowel Reinforcement	60
Figure 10.9 :	Details for Gable Band	61
Figure 10.10 :	Details for Diagonal Bracing	62
Figure 10.11 :	Lateral Restrainers	63
Figure 11.1(A) :	Damp-Proof Course	64
Figure 11.1(B) :	Damp-Proof Course	65
Figure 11.2 :	Surface Water Drainage around the building	65

0. Foreword

0.1 Introduction

A number of documents for better seismic-resistant constructions have been prepared under the National Building Code Development Project (NEP/88/054/21.03) in 1993. **Guidelines for Earthquake Resistant Building Construction: Low Strength Masonry (LSM)** is one of them. Originally prepared document has been revised by DUDBC in July 2014. This document provides basic guidelines for the earthquake resistance of low-strength masonry construction.

0.2 Objective

This guideline is prepared in order to raise the seismic safety of low-strength masonry buildings. This is intended to be implemented by the owner/builder with some assistance from the technicians. This could also act as a basic guideline for architectural design and construction detailing of Low Strength Masonry (LSM) buildings.

0.3 Background

The devastating earthquakes in the past have proved the vulnerability of most of the vernacular buildings of Nepal. Enormous life and property were lost due to the collapse of buildings which LSM as the main load-bearing element. Earthquakes can neither be prevented nor predicted precisely. But the large-scale destruction can be minimized by employing seismic-resistant measures in buildings. This can be achieved by the use of existing building materials in appropriate ways. This **Guideline for Earthquake-Resistant Building Construction: Low Strength Masonry** provides the improved techniques that can raise the level of seismic safety of low strength masonry buildings.

0.4 Applicability

The recommendations set forth in this standard shall be mandatory for all types of LSM residential buildings to be built throughout Nepal.

Other occupancy types of LSM buildings shall be designed by competent professional engineers.

0.5 Interpretation

0.5.1 In this standard the word "shall" indicates a requirement that must be adopted in order to comply with the Standard, while the "should" indicates recommended practice.

0.5.2 Words used in either singular or plural shall be treated as plural or singular as deemed necessary and vice-versa, wherever the context so requires it.

0.6 Terminology

In this standard, unless inconsistent with the context:

LSM means **Low strength masonry** load bearing masonry wall constructed with:

- Non-erodible walling units such as stones, burnt clay bricks, stabilized soil blocks etc.
- Mud Mortar as a binder.

1 Scope

1.1 Type of Buildings Covered

This standard shall be valid for the construction of LSM buildings as defined in clause 0.6. Naturally, there is nothing preventing designers/builders exceeding the standards set out in this standard.

1.2 Limitation

LSM buildings required to conform to this standard shall not exceed two stories in height with an additional attic floor.

2 General Requirements for Earthquake Resistance Construction

The principal seismic resistant factors have to be properly incorporated during the construction of a building. Some basic factors leading to enhanced seismic safety are:

2.1 Proper Site Selection

The construction site has to be stable and safe enough to withstand the total building load, including that of its occupants and their belongings. A proper site for the building shall be selected in accordance with section 4 of this guideline.

2.2 Appropriate Planning

The shape, size and proportion of a building is important for its seismic safety. Buildings with asymmetric plan and elevation are more vulnerable to earthquake than those having symmetrical ones. The recommended form and proportion of buildings shall be as stated in section 5.

2.3 Good Foundation Resting on a Firm Base

The quality of foundation and the base on which the foundation rests are equally important for the safety of a building. General site investigation shall be carried out as outlined in section 4. The dimensions and quality of masonry for the foundation shall be as stated in section 6.

2.4 Creating a Box Effect

The building has to act as a single unit for it to have good earthquake resistance. This can be achieved by incorporating certain elements in the construction. The following elements shall be introduced as recommended in section 10.

- Vertical reinforcement
- Horizontal bands well-connected to the vertical reinforcements and embedded in masonry
- Diagonal bracing (horizontal and vertical)
- Lateral restraints

2.5 Better Bonding between Masonry Units

The type and quality of the bond within the walling units is the main contributor to the integrity and strength of the walls. All the masonry units have to be properly laid to provide the integrity.

2.6 Controlled Size and Location of Openings

Large un-stiffened openings create soft-storey effect which leads to a greater deformation of building during an earthquake. To prevent such effects, the opening size and location have to be controlled. The recommended proportions and locations of openings are given in section 8.

2.7 Light Construction

As the damaging forces during earthquake shaking of the building are directly proportional to the mass of the building, lighter structures will attract less earthquake force, and hence less damage. Lighter materials like timber and bamboo are preferred provided they are available and suitable, considering all other constraints. The wall thickness shall be as low as possible, but in no case less than 230mm for brick masonry and 350mm for stone masonry in mud mortar.

3 Materials

3.1 Boulder Stones

Boulder stones shall never be used in its natural shape. These boulders shall be broken before they are laid. The broken boulders shall have flat bedding-surface on top and bottom. Such broken boulders shall not be less than 50 mm in thickness and 150 mm in width and length, except in case of fillers required for proper bonding.

3.2 Quarry Stones

Easily-breakable soft stones shall not be used. Only solid quarry stones with no obvious fractures shall be used. These stones shall not be smaller than 50 mm in thickness and 150 mm in length or breadth. However, the fillers required for proper bonding may be smaller.

3.3 Dressed Stones

In this form of masonry stones shall be chisel dressed on all faces to have perfectly square or rectangular faces so that accurate bedding and jointing is possible. This type of stone masonry is preferable for construction.

3.4 Stabilized Soil Block

Stabilized soil blocks to be used for the masonry shall be free from major deformation and visible cracks. The stabilized soil blocks can be prepared from soil mixed with stabilizers such as lime, cement, bitumen, and the alike. The size of stabilized soil blocks are generally 300mmx150mmx100mm. The crushing strength of stabilized soil blocks shall not be less than 3.5N/mm².

3.5 Brick

The bricks shall be of a standard rectangular shape, burnt red, hand-formed or machine-made and shall conform to the Nepal Standard NS: 1/2035. Bricks used as masonry units shall be of class A1 or class B1 as per NS: 1/2035 with compressive strength not less than 3.5 N/mm². Over-burnt, Under-burnt and deformed bricks shall not be used.

3.6 Mud Mortar

Mud for mortar shall be free from organic materials. It shall also be free from pebbles and other hard materials which could upset the mortar thickness. The sand content in the mud shall not be more than 30 % in order to achieve a proper cohesiveness. Dry mud shall be thoroughly kneaded with water in order to prepare the dense paste.

3.7 Bamboo

Only matured bamboo that is a minimum of three years old and free from damage shall be used. It is preferable that treated bamboo be used. The treatment may be carried out in a traditional manner. One of the simplest ways is to soak the bamboo in running water continuously for two to three weeks. (Details are presented in Appendix 1.)

3.8 Timber

Well-seasoned locally available timber can be used. Seasoning should be done in a traditional manner. Preferably Sal wood, or any other locally available hardwood timber, shall be used instead of softwood timber for the main structural elements such as beams, columns, bands, etc. (According to indigenous experience, deciduous trees are much less susceptible to bacterial and insect rot if felled during August to December). List of the hardwood and softwood timber available are as follows:

Table 3.1: List of hardwood and softwood

HARD WOOD	SOFT WOOD
Babul	Chir
Black Siris	Deodar
Dhaman	Jack
Indian Rose Wood(Shisam)	Mango
Jaman	Salla
Mesua	Simal
Oak	Uttis (Red)
Sain	Uttis (White)
Sal	
Sandan	
Sisso	
Teak	
Khair	

3.9 Reinforced Concrete

In areas where cement, sand, aggregate and reinforcing steel are available, reinforced concrete may serve as an additional building material. The steel used shall be free from heavy rust and scale. Cement shall be so stored that that is not affected by moisture. The mix ratio of shall not be leaner than 1:2:4 (cement: sand: aggregate) .The maximum free water cement ratio shall not exceed 0.6. The quantity of water added during the mixing shall be kept to a minimum. The addition of more water although increases the workability, but reduces its final strength. It should be mixed thoroughly to prepare a homogenous mix of sufficient workability. Proprietary admixtures can be added to increase workability, and waterproofing compounds can be added to achieve better water-proofing.

4 Site Consideration

4.1 General

The building site shall be the safest available with respect to natural hazards. Any existing buildings shall be studied for any evidence of inherent natural hazards in the locality. These hazards include susceptibility to landslides, erosion and land subsidence. The local practice used to manage such hazards, if any, shall be judged against the required level of acceptable risk. Areas with high potential of liquefaction during earthquake should also be avoided.

4.2 Site Selection

Site selection shall be done so as to minimize the risk against natural hazards. No buildings shall be constructed in the hazardous areas, including the areas stated here under.

4.2.1 Geological Fault or Ruptured Areas.

Geological fault lines or rupture lines that are usually visible to the naked eye and are permanent, deep and active should be avoided. Buildings should be constructed at least 500 m away from these lines. (Light and flexible structures may be built closer)

4.2.2 Areas Susceptible to Landslide.

Areas likely experience frequent landslides shall be avoided for construction of buildings. The simplest indication of sustained stability of a slope is the upright standing of the trees on it. They would be inclined downwards in the case of unstable slopes.

4.2.3 Boulder Hazard.

Nepal, being a mountainous country, has many places where boulders roll down the bare hill slopes. These boulders can hit and damage the building. Therefore, buildings shall be constructed in such areas only after the provision of proper prevention by retaining walls and green barriers of bamboo groves is assured.

4.2.4 River Bank

It is preferable that river banks and areas susceptible to frequent flooding should be avoided. Constructions on such areas can be undertaken only after carrying out protection works as suggested by specialists.

4.2.5 Swamp/Marshy Area

Constructions on swamps or marshy areas should only be undertaken on specialist advice.

4.2.6 Steep Slope

Generally, soil slopes up to 20° are stable and good for construction. However, constructions on steeper slopes is not restricted if there are proper retaining walls for the development

4.2.7 Water-Logged Area

Sites with permanent water-logged areas should be avoided. However, construction is allowable if the site is appropriately treated.

4.2.8 Filled Area

No building foundations shall rest on uncompact filled ground. If a building is to be constructed in a filled-ground, the foundation shall be deep enough so as to rest on the firm ground surface beneath the fill. Such depth should be minimum 600mm below from the firm ground.

4.3 Site Investigation

A site investigation to determine soil type should be carried out. A minimum of two test pits for each building should be made. The minimum depth of such test pits should be 2.00 m. unless a sound bedding surface like hard rock, conglomerate, etc., is found at a lesser depth.

4.4 Classification of Soil Type

The soil taken from the test pit should be classified as per **Table 4.1**.

SOIL CLASSIFICATION	DESCRIPTION OF SOIL TYPE	REMARKS
Hard	<ul style="list-style-type: none"> a. Rocks in different state of weathering. b. Boulder bed and gravel. c. Sandy gravel. d. Dense or loose, coarse to medium, sand offering high resistance to penetration by tools. e. Stiff to medium clay which are readily indented by a thumb nail. 	
Medium	<ul style="list-style-type: none"> a. Fine sand and silt (dry lumps easily pulverized by the finger). b. Moist clay and sandy clay that can be that can be indented with thumb pressure 	
Soft	<ul style="list-style-type: none"> a. Fine sand loose and dry. b. Soft clay indented with moderate thumb pressure. 	
Weak	<ul style="list-style-type: none"> a. Soft clay which can be penetrated several centimeters with thumb. b. Wet clays 	Buildings shall not be constructed in weak soil.

Table 4.1: Classification of Soil Type

5 Planning

5.1 Shape

Buildings which are symmetrical in plan and regular in elevation are safer than the asymmetrical ones. Thus, it is preferable that buildings be symmetrical and regular. The different forms of recommended geometrical configurations are illustrated in Figure 5.1.

NO		YES	
PLAN	ELEVATION	PLAN	ELEVATION
 <p>$a \geq 3b$</p>		 <p>$a \leq 3b$</p>	
 <p>$a = b$ $a' = b'$</p>			
		 <p>min 2W</p>	
	MORE THAN 3 STOREYS		MAXIMUM STOREYS 2 + ATTIC

Figure 5.1 : Recommended Forms of Buildings

5.2 Proportion.

The length to breadth ratio of a building shall not exceed 3:1. The length to breadth ratio for any room or area enclosed by load-bearing walls inside the building shall also not exceed 3:1. The building height shall not be more than three times the width of the building.

5.3 Storey Height

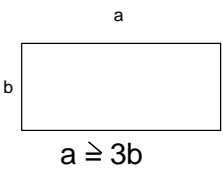
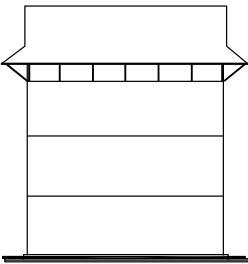
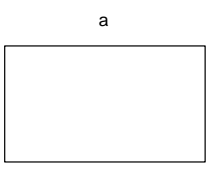
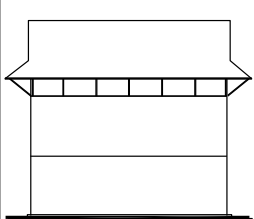
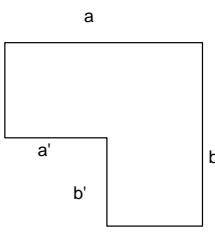
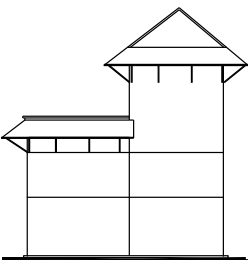
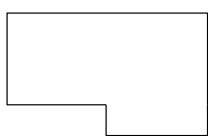
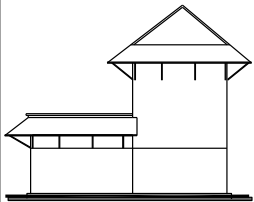
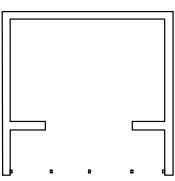
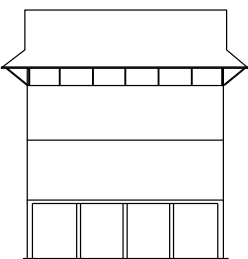
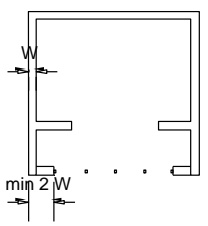
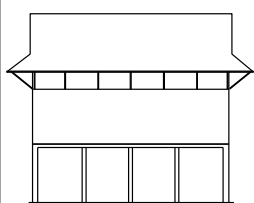
The floor to floor height of LSM building shall not be less than 2 m and not greater than 3 m. In case of the attic floor, maximum height from floor level to ridge level shall be 1.8m and maximum height from floor level to eave level shall be 1m.

5.4 Number of Storey

The buildings may have up to two stories and an additional attic floor. The maximum height (floor to floor) of a building shall not exceed 12 times the wall thickness at the superstructure.

5.5 Plinth Level

The height of plinth level shall be at least 300mm from existing ground level. The height of plinth level can be changed as per site condition such as surrounding road level, rainfall intensity of area, drainage condition etc.

6 Foundation

6.1 General

The foundation trench shall be of uniform width. The foundation bed shall be on the same level throughout the foundation in flat area.

6.2 Strip Footing

The minimum size of the footing for each classification of soil type shall be as stated in Table 6.1. The construction details and dimensions of the strip footings shall not be less than those illustrated in Figure 6.1. The depth of such footing shall be at least 750mm.

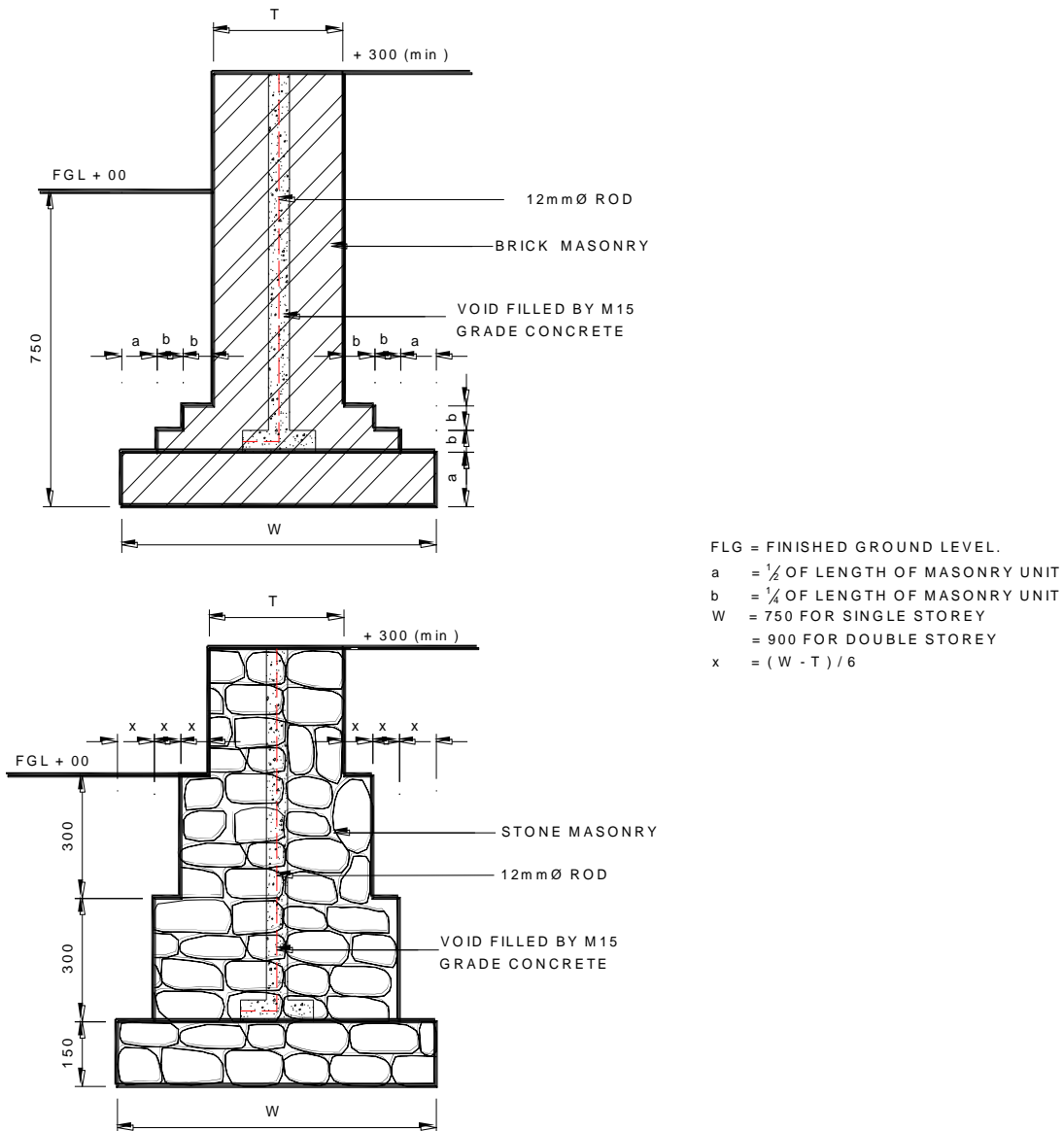

**Figure 6.1: Details of Strip Footing Masonry Foundation
 (Where cement and concrete available)**

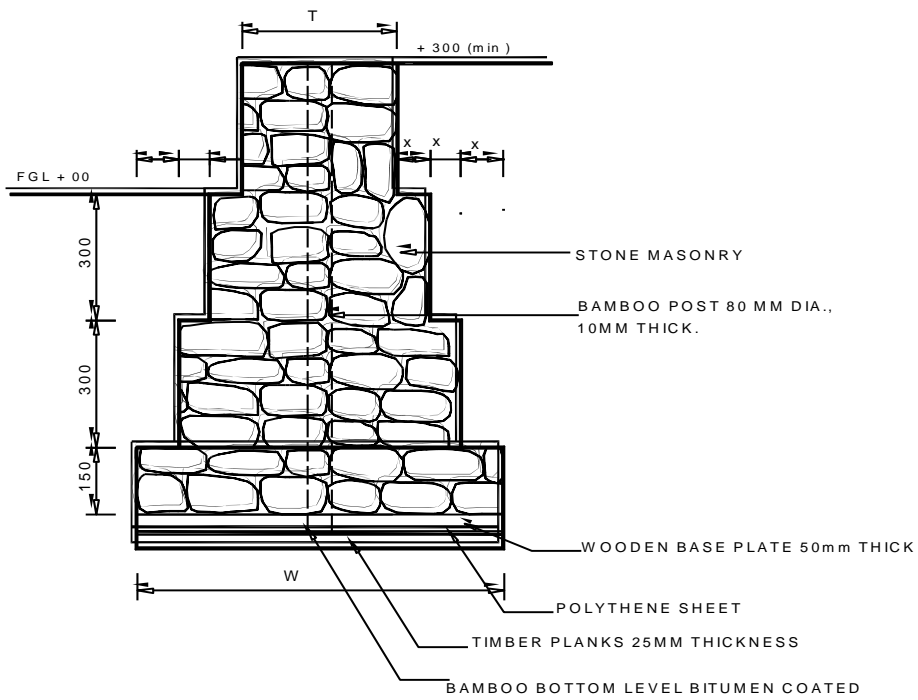
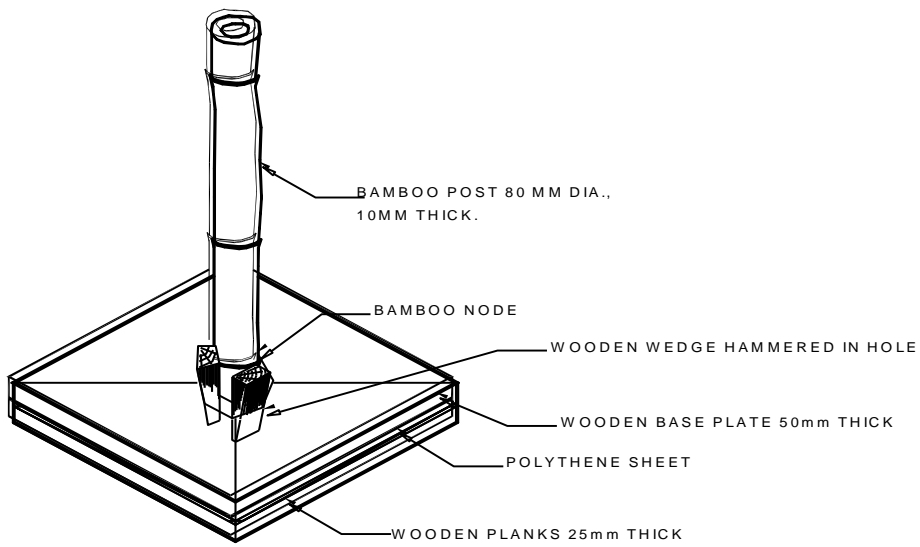

**Figure 6.2: Details of Strip Footing Masonry Foundation
(Where cement and concrete not available)**

TYPE OF CONSTRUCTION	SOIL TYPE	NO OF STOREY	
		One	Two
BRICK	Hard	550	650
	Medium	650	750
	Soft	750	900
STONE	Hard	750	750
	Medium	750	800
	Soft	800	*

Table 6.1: Size of Strip Footing for Different Soil Types

Note:

1. Soil type assumed to be same throughout the site.
2. Foundations not required for hard rock bed.
3. LSM building shall not be constructed in weak soil.
4. (*) Two storey LSM building with stone as building block shall not be constructed in soft soil.

6.3 Masonry for Foundation

Masonry units shall be large flat-bedded stones or regular-sized well-burnt brick. Mortar joints shall not exceed 20 mm in any case. All the vertical joints shall be kept staggered in alternate layers. Mud packing in the core of foundation shall not be permitted. The gaps in the core shall be well-packed with the masonry units.

6.4 Foundations on Sloping Site

No building shall be built on land steeper than 20° (1:3, Vertical: Horizontal). Stepped strip footing shall be made for foundations on sloping land. The minimum depth of a foundation shall be measured from the existing ground level on the filled part and from the finished ground level on the cut part, and this shall not be less than 750 mm. Each step shall not be narrower than two times the wall thickness at the base of the superstructure, as shown in Figure 6.3.

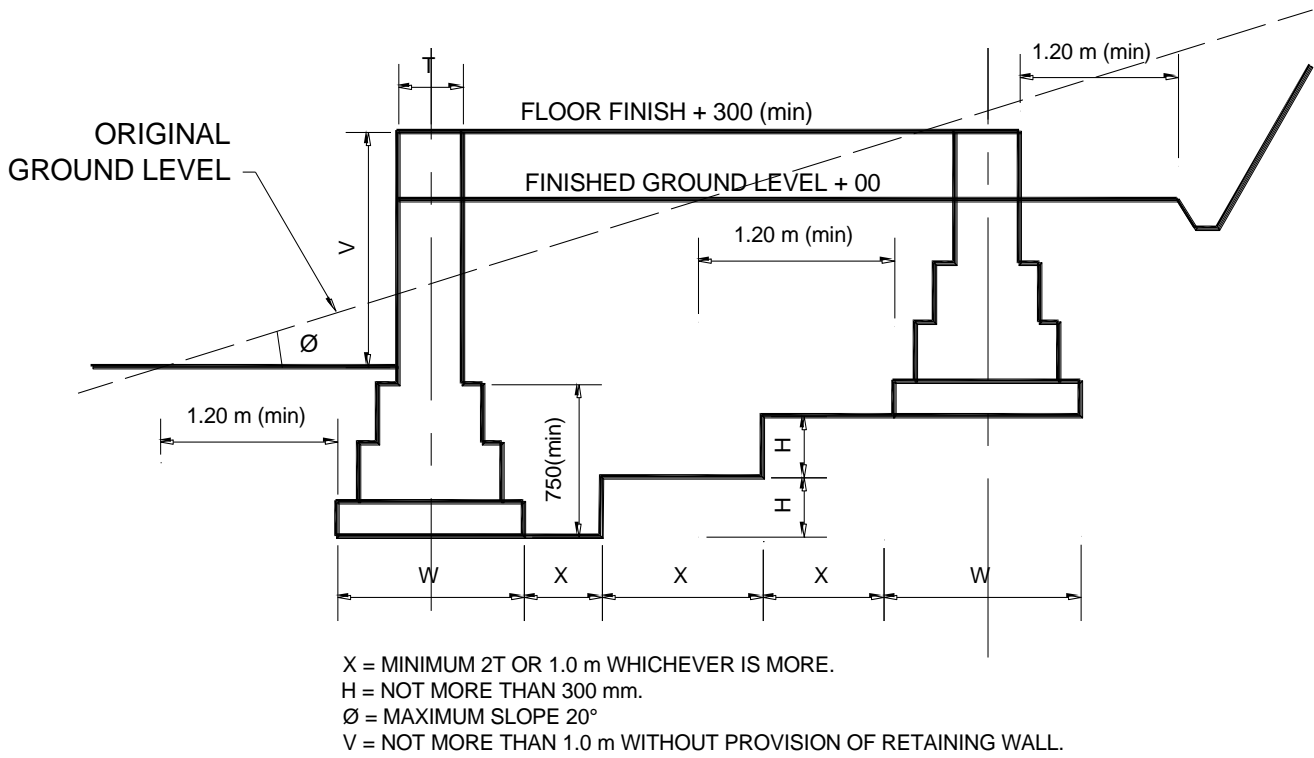

Figure 6.3: Foundation on Sloping Land

7 Wall

7.1 General

Walls in the foundation and superstructure shall be true to plumb line (i.e. vertical). Mortar packing in the core shall not be permitted. The core shall be well-laid with the walling units. Mortar joints shall not be more than 20 mm and less than 10 mm in thickness. Vertical joints in alternate layers shall be staggered. The width of the wall shall be uniform. The wall shall have plenty of through-stones extending the whole width of the walls. The maximum spacing of such through-stones shall be 1200 mm in the horizontal direction and 600 mm vertically. Alternatively, seasoned wooden dowel or precast concrete or in situ concrete may be used instead of through-stones as shown in fig 7.1(a). Only large, flat stones shall be used to make corners and junctions. Instead of leaving toothed end up a vertical line, stepped construction that allows interlocking between walls at staggered vertical sections should be provided. When irregular walling units such as undressed stones are used, layered construction that is continuous about the perimeter of the walls shall be carried out. The detailing and size of through-stones could be as illustrated in Figure 7.1

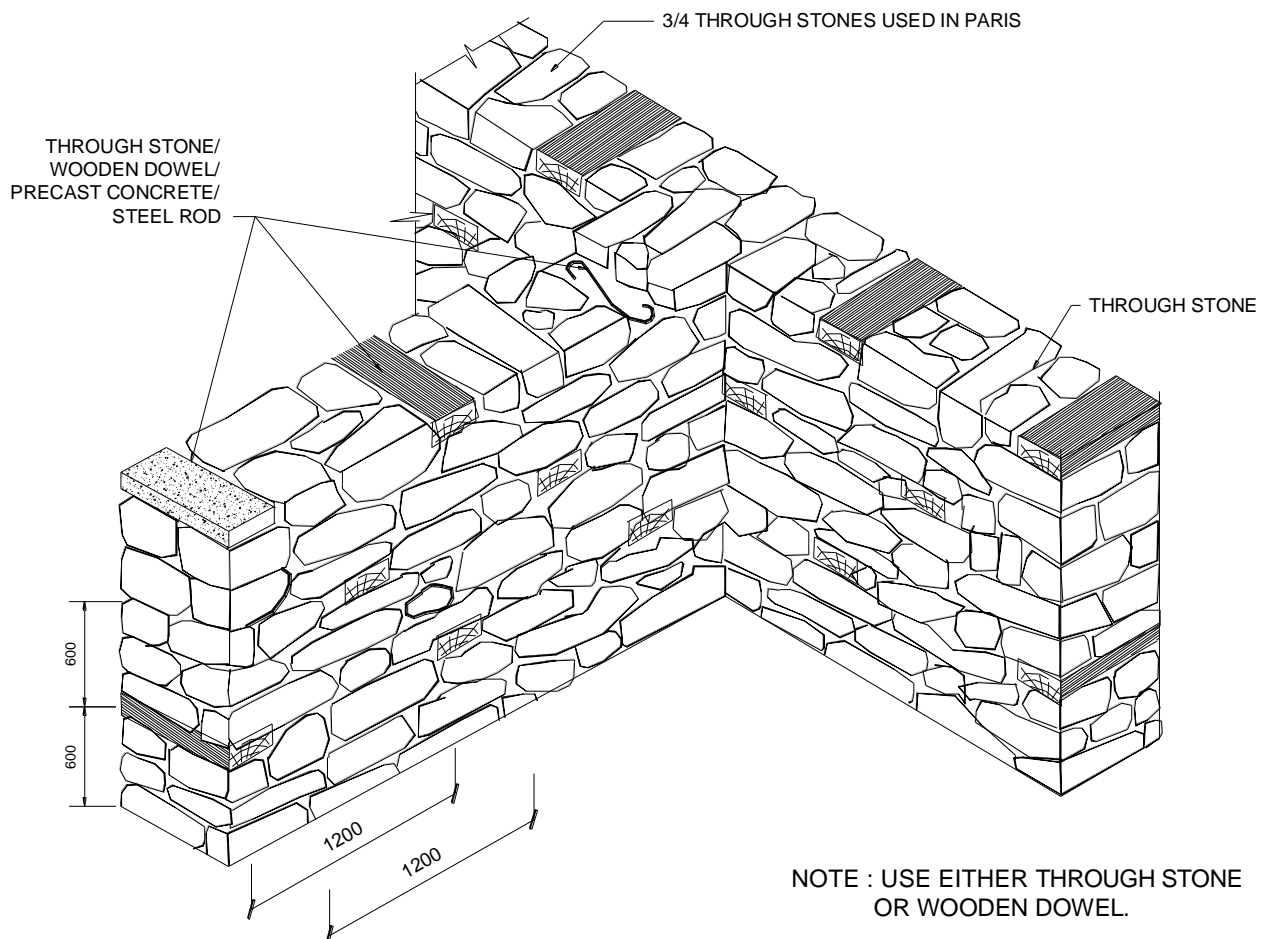
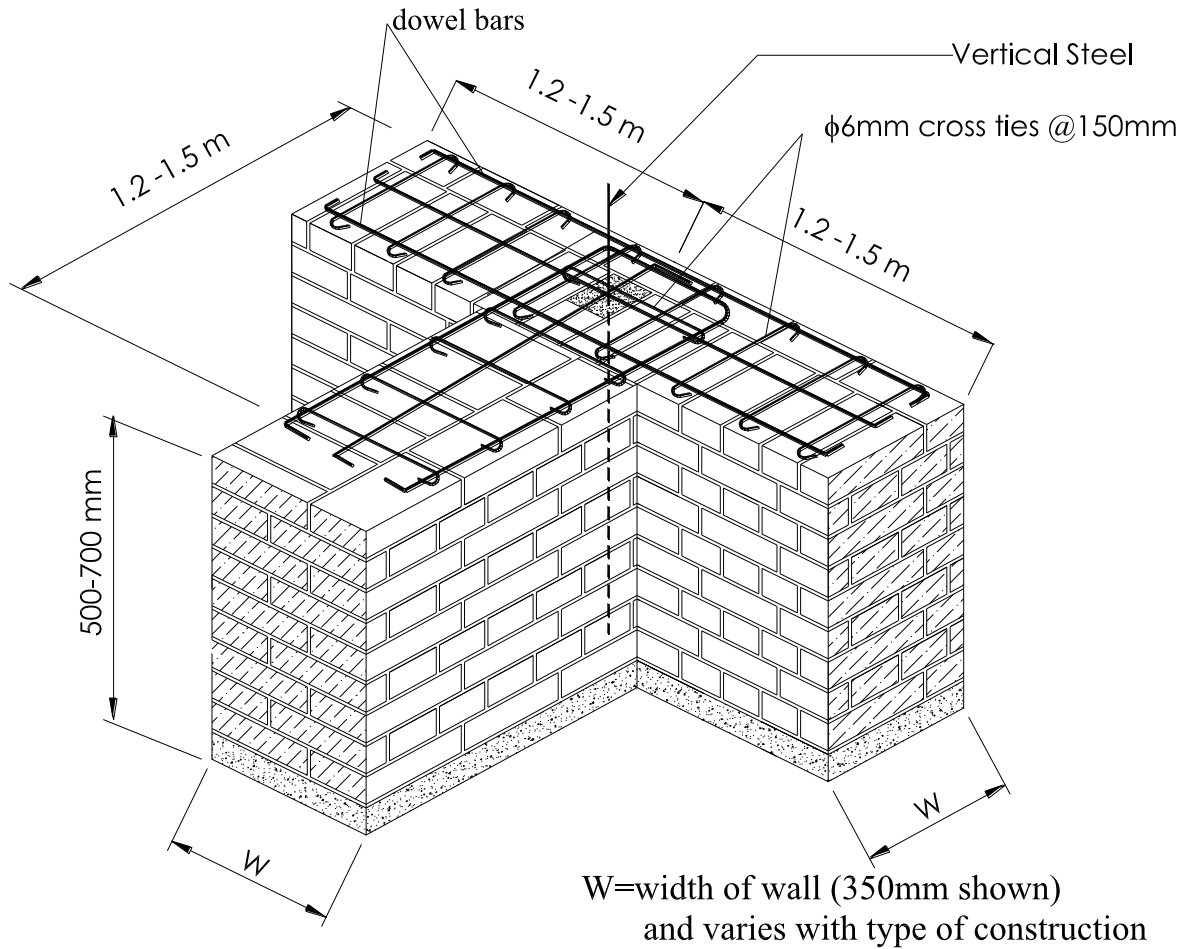

Figure 7.1(a) : Details of Wall Construction (Stone Masonry)



[The dowel bars shall be provided with at least 3-nos of 10mm dia mild steel bars or equivalent HYSD bars]

Figure 7.1(b) : Details of Wall Construction(Brick Masonry)

7.2 Wall Thickness

The minimum thickness of walls for different storey heights shall not be less than those stated in **Table 7.1**.

MASONRY TYPE	NO OF STOREY		
	One	Two	Two Plus Attic
Stone	350-450	450	450
Brick	230	350	350
Stone /Cement Solid Block	300	300	300
Stabilized Soil Block	300	300	300

Table 7.1(b) : Minimum Wall Thickness (mm) for Different Storey Heights

7.3 Unsupported Wall Length

The maximum length of unsupported wall shall not exceed 12 times its thickness. If it is necessary for a wall to be longer than 12 times its thickness, it shall be provided with a buttress at intervals not exceeding 12 times the wall thickness. Thickness of such buttress wall shall be equal to the thickness of wall and width of the buttress shall be equal to thickness of wall from the external face of wall at the top and shall extend upto $h/6$ at the bottom from the external face of the wall, h being the height of buttress. The details as illustrated in **Figure 7.2** could be used for such buttresses.

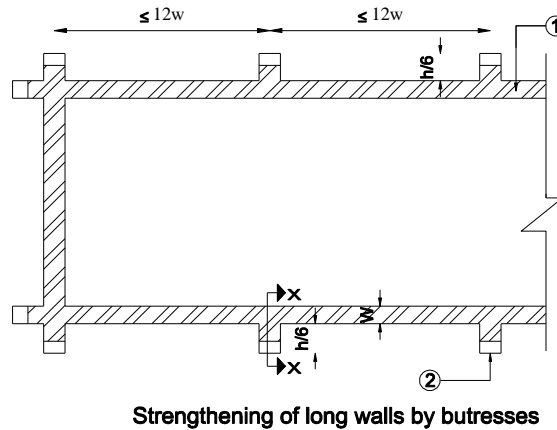

Figure 7.2 : Buttress on Walls

7.4 Height of Walls

The thickness to height ratio of a wall shall not be more than that stated in **Table 7.2**. However storey height shall also be as per clause 5.3.

MASONRY TYPE	RATIO
Stone	1:8
Brick	1:12
Stone/Cement Solid Block	1:12
Stabilized Soil Block	1:12

Table 7.2 Maximum Thickness to Height Ratio of Walls

8 Openings in Walls

Openings in a wall generally describe those for doors and windows. However, the partial puncture of a wall such as that for a wardrobe, for a built-in closet, or for a *Dalan* covered verandah with walls on three sides, shall also be considered as openings in this guideline.

Unbalanced openings contribute to the increased vulnerability of buildings during an earthquake. For buildings to be safer, the size and location of the openings shall be controlled as illustrated in **Figure 8.1**.

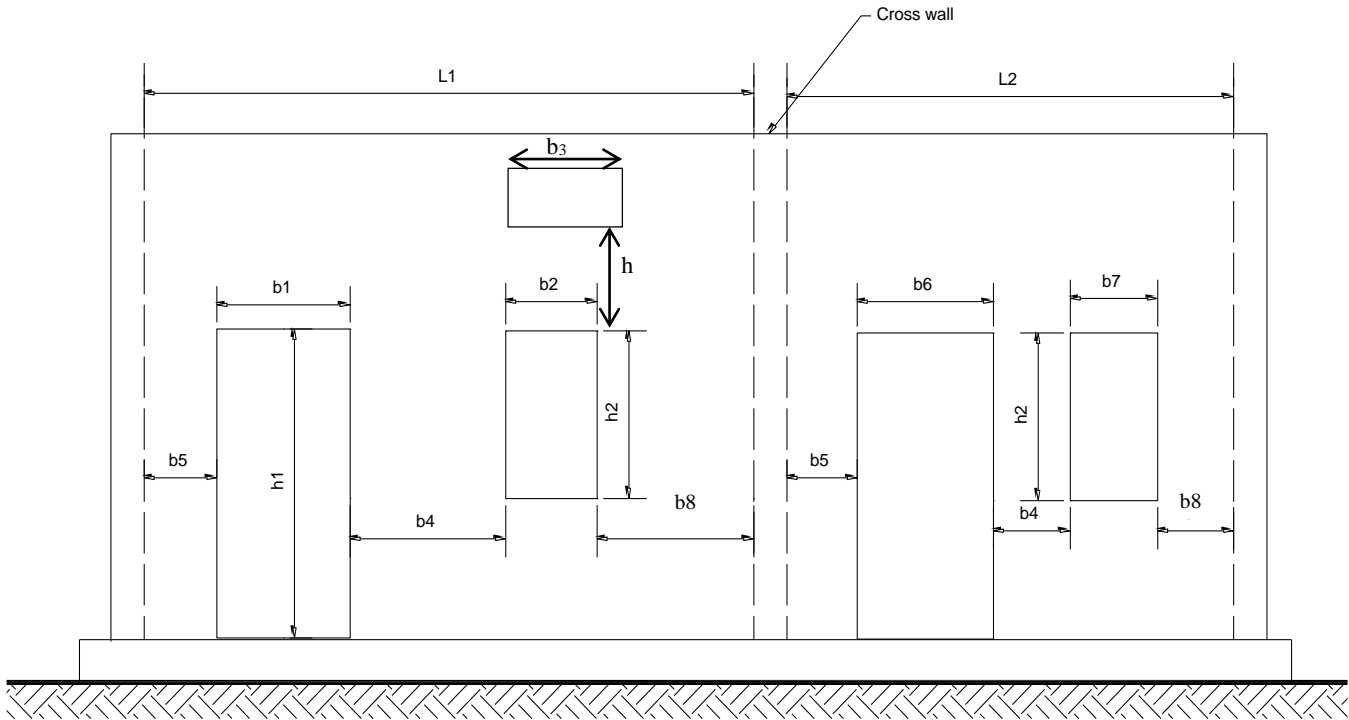

RECOMMENDATION REGARDING OPENINGS IN LOAD BEARING WALLS

NOTE:

$b_1 + b_2 < 0.3 L_1$ for one storey, $0.25 L_1$ for two storey

$b_6 + b_7 < 0.3 L_2$ for one storey, $0.25 L_2$ for two storey

$b_4 \geq 0.5 h_2$ but not less than 600 mm.

$b_5 \geq 0.25 h_1$ but not less than 600 mm.

$b_8 \geq 0.25 h_2$ but not less than 600 mm

$h \geq (\text{greater of } 0.5b_2, 0.5b_3)$ but not less than 600 mm

Figure 8.1: Location of Openings

8.1 Maximum Combined Width of Openings

The maximum combined width of the openings on a wall between two consecutive cross-walls shall be restricted as following.

For one-storey buildings, the openings shall not exceed 30 % of the total wall length.

For two-storey buildings, the openings shall not exceed 25 % of the total wall length.

8.2 Position of Openings

Openings are to be located away from inside corners by a clear distance equal to at least $1/4^{\text{th}}$ of the height of the opening, but not less than 600mm.

The horizontal distance (pier width) between two openings is to be not less than one half of the height of the shorter opening but not less than 600mm.

The vertical distance between two openings shall not be less than 600 mm or half the width of the smaller opening, whichever is the greater.

No *Dalan* shall have a wall-to-wall opening. The corners shall be extended a distance at least equal to the wall thickness along the *Dalan* for such openings.

9 Floors and Roofs

Buildings should be as light as possible in order to make them more seismic-resistant. The practice of laying thick layer of mud to achieve a firm floor/flat roof is common. This increases the overall building weight. The thickness of the mud layer used for flooring/roofing shall be kept as small as possible. The roof covering shall project minimum of 450mm around all the exterior walls.

9.1 Structure

The following points shall be duly considered when selecting the materials for flooring structures :

- Locally available hardwood species shall be preferred to softwood species for the structural elements of flooring.
- Using a whole tree trunk as a structural element not only increase the weight, but also makes the wood more susceptible to termites attack. This results in a shorter life for such elements. Hence, only sawn timbers should be used.
- Seasoned and treated timber or bamboo shall be used. Simple methods of treating and seasoning timber and bamboos are given in appendix 1. These should be carried out prior to the placement of these structural elements.

9.1.1 Posts and Capitals

Circular posts shall be preferred for posts, the whole tree trunk being used only after removal the bark and the sapwood.

Whenever sawn timber is used for posts, it should be square in section. The minimum size for various column spacing shall be as tabulated in **Table 9.1**.

SPECIES	Size of Column for Post spacing of			
	2 m	2.5 m	3 m	3.5 m
Hardwoods	110x110	110x110	120x120	130x130
Softwoods	120x120	120x120	130x130	140x140

Table 9.1: Size of Posts (mm)

(Note: For circular section, radius(r) is taken such that total area is unaltered.)

Each post shall rest on a firm base pad of stone or timber base. The base pad should have a groove in to which the post shall be housed. The details could be as shown in **Figure 9.1**.

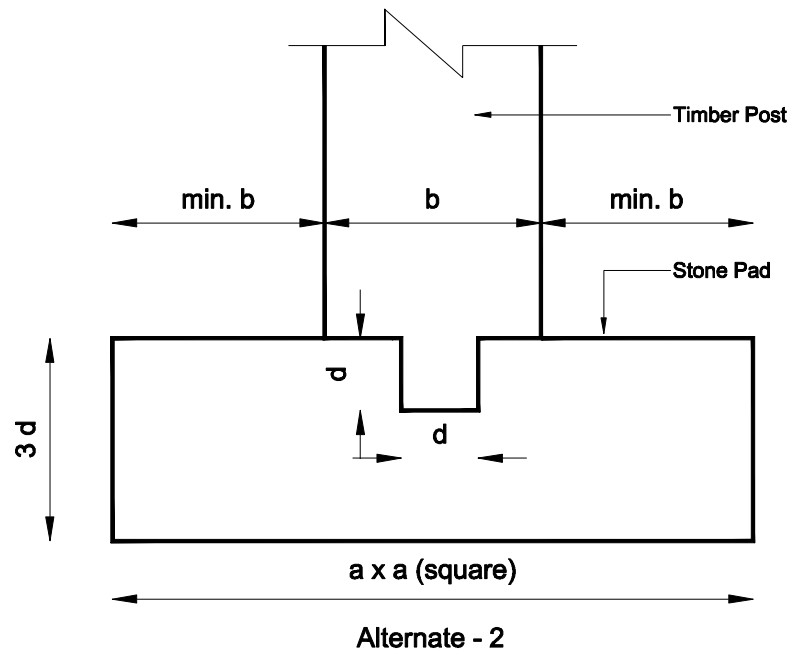
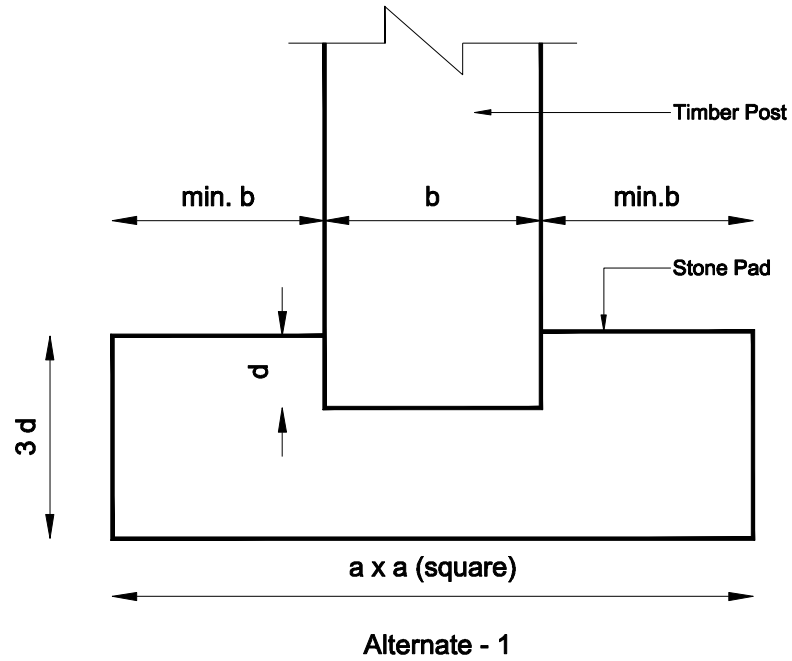

$a = 3b$ or greater
 $d = b/3$ OR 50mm, whichever is maximum
 $b =$ size of post

Figure 9.1: Details of Fixing Posts on Base Pad

Whenever a series of posts are erected on the same horizontal line, they should be founded on a horizontal timber member as shown in **Figure 9.2**. The minimum

depth of such a horizontal timber shall be 75 mm for hardwood and 100 mm for softwood species. The breadth of these horizontal elements shall not be less than the size of the posts they support.

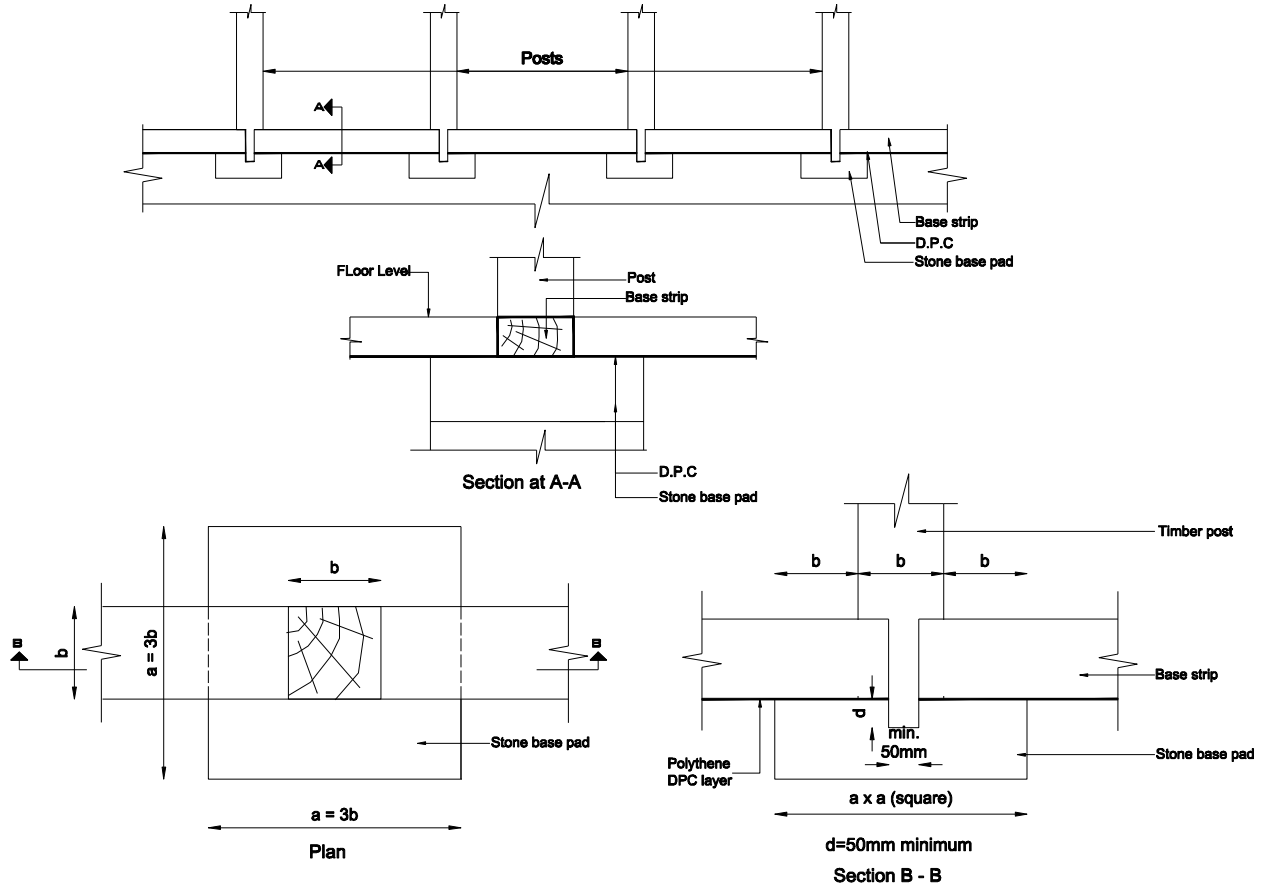

Figure 9.2: Details of Fixing of a Series of Posts on Base Strip

Each posts shall have a properly connected *Meth* (capital) on its top end. The minimum dimensions of such capitals shall be as given in **Figure 9.3**. Alternatively, the capitals may be replaced by struts well-connected to the posts and beams, as shown in **Figure 9.4**.

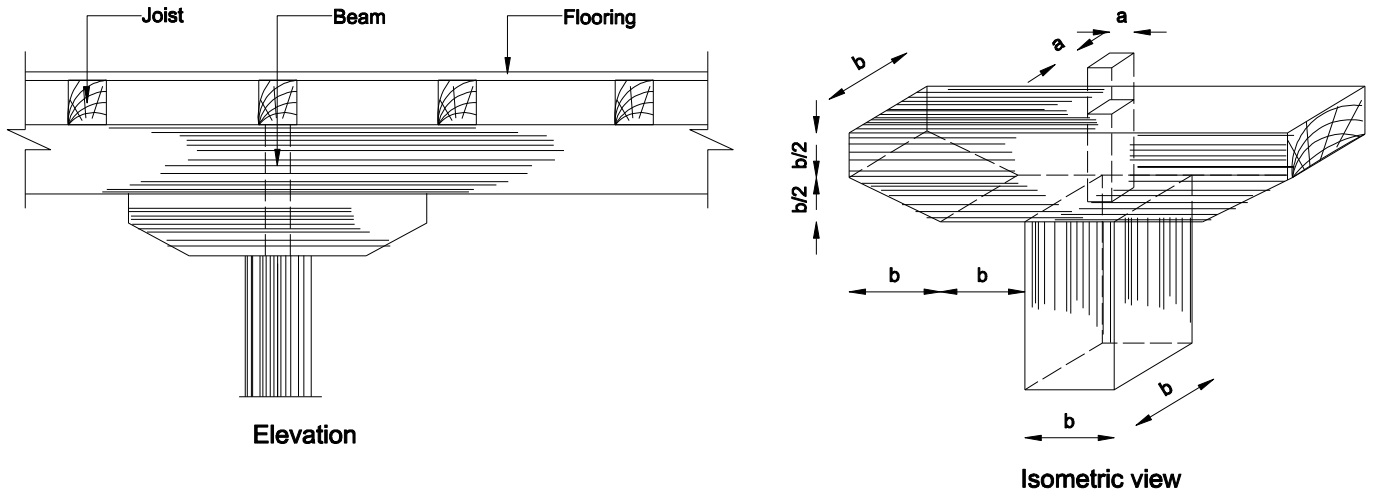

Figure 9.3: Details of Fixing Capitals on the Posts

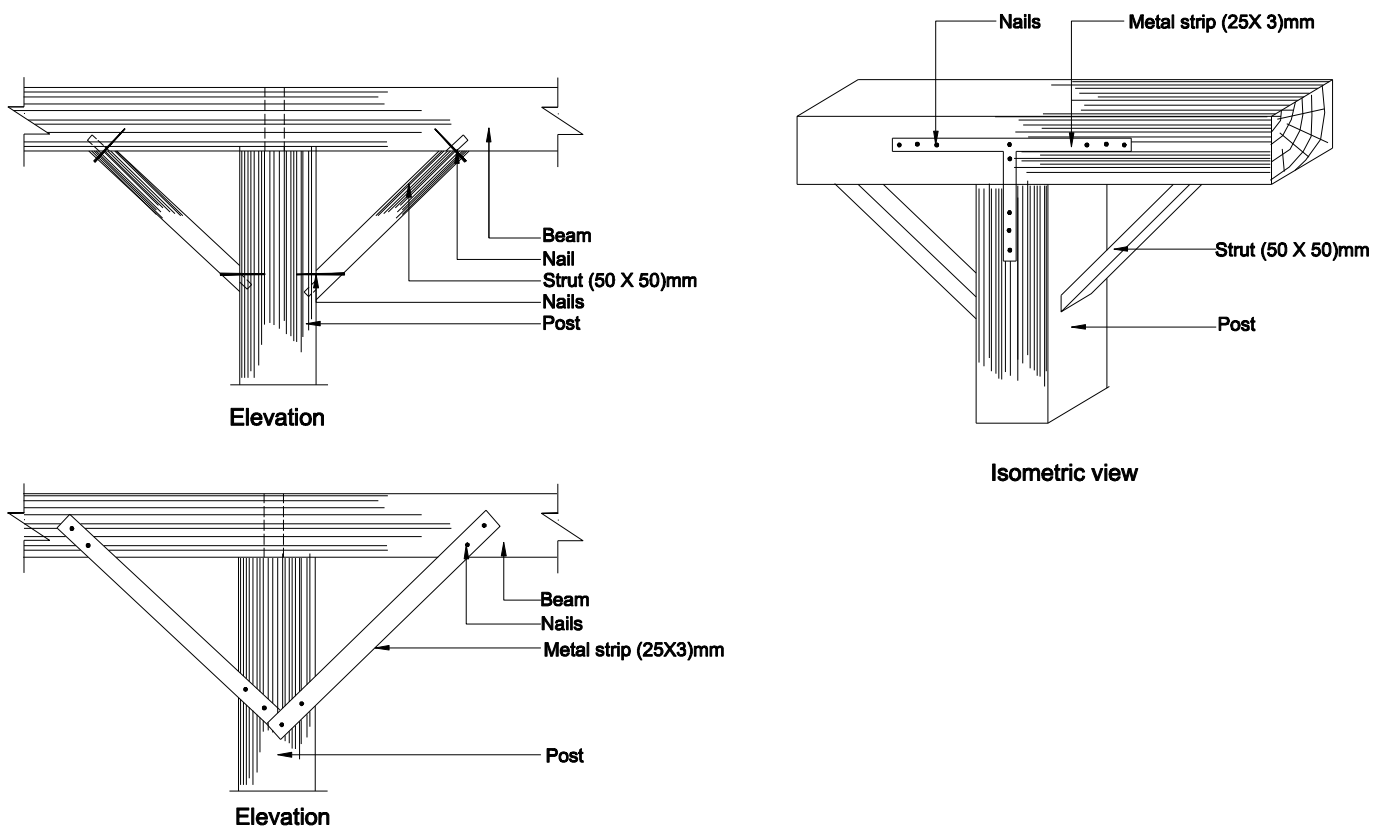
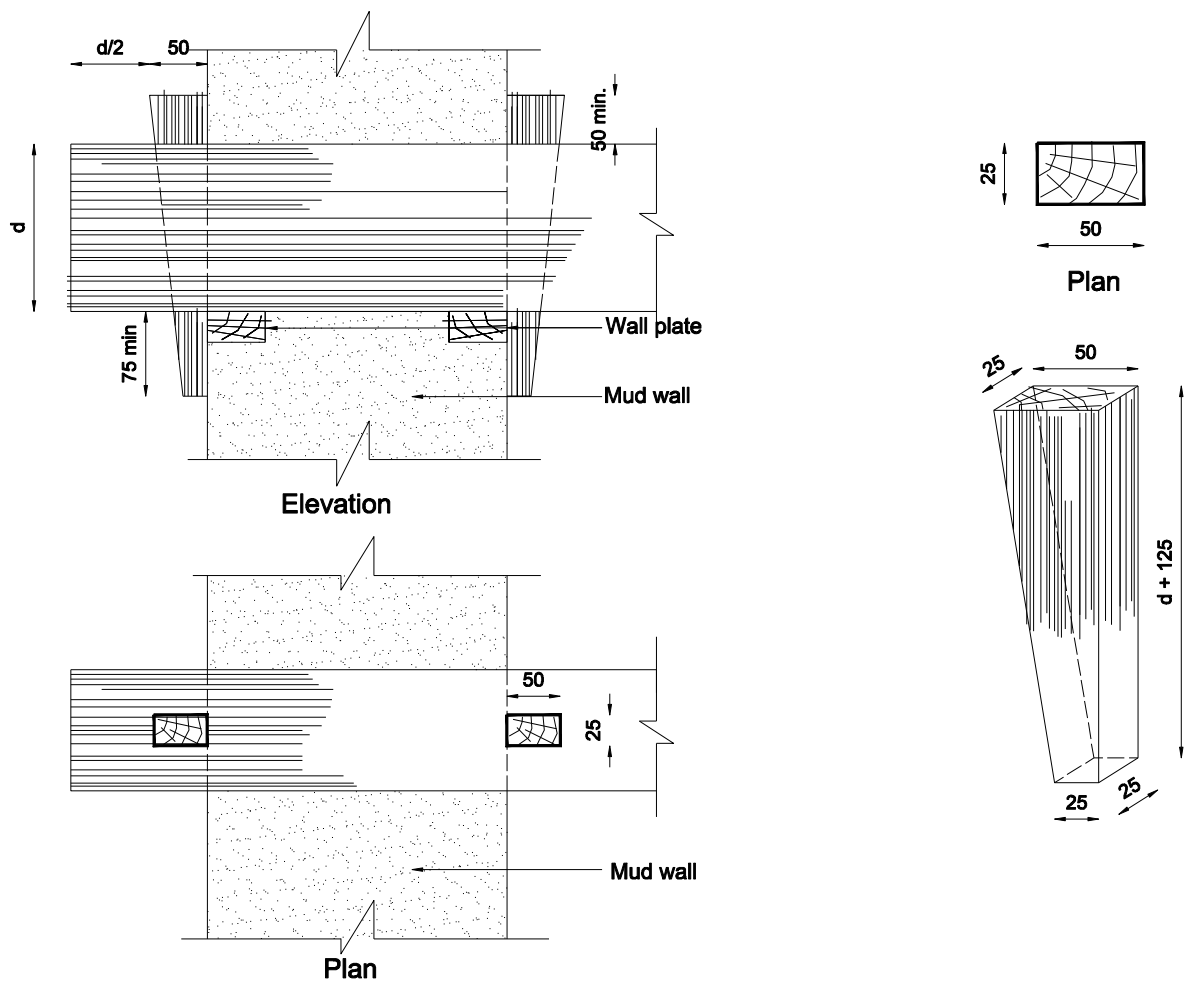

Figure 9.4: Alternative Details of Fixing Struts on Posts and Beams

9.1.2 Beams and Bearings

Beams shall never rest directly on a wall. A base pad for the beam shall be provided. This pad should be either of timber or a large flat stone covering the whole width of the wall. The minimum thickness of such a pad shall be 75 mm.

The beam shall be long enough to extend beyond both the supporting walls. Timber keys shall be provided on both the external and internal walls as shown in **Figure 9.5**.



**Figure 9.5(a): Details of Fixing Keys on Beams
(In areas where steel and concrete are not available)**

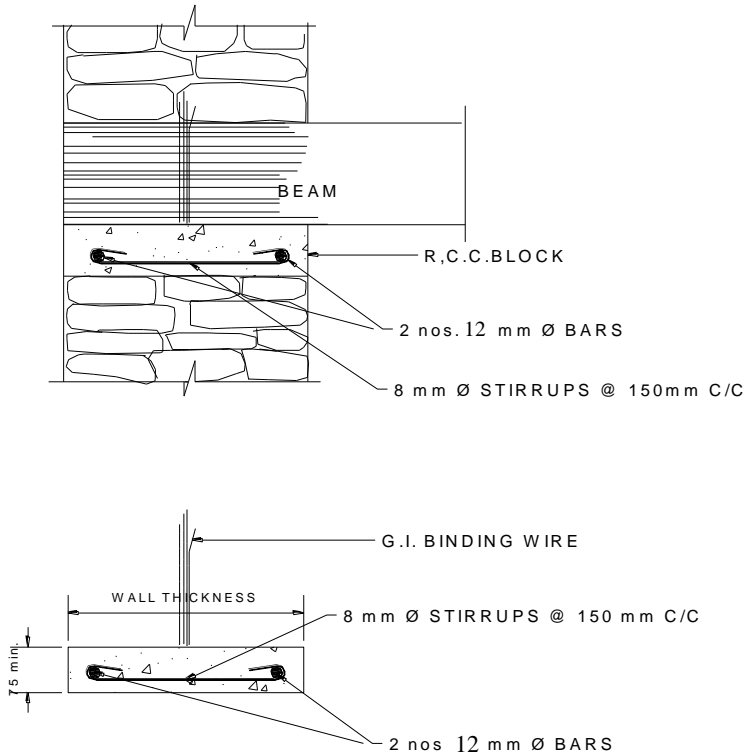

**Figure 9.5(b): Details of Wire Binding of Beams to Bands
(In areas where steel and cement are available)**

The beams shall be rectangular in section and shall never be laid wider surface horizontal. The minimum dimensions of the beams for different spans shall be as tabulated in **Table 9.2**.

SPECIES	Size (DxB) of Beam for SPAN of				
	2 m	2 to 2.5 m	2.5 to 3 m	3 to 3.5 m	3.5 to 4m
Hardwood	190x100	220x100	240x120	270x140	300x150
Softwood	230x120	270x140	310x150	340x160	370x170

Table 9.2: Size of Beams (mm) for Various Spans

9.1.3 Wall Plates

Wall plates or horizontal bands shall extend all around the walls. They shall be placed on the wall so that the joists rest on them. The fixing details and minimum dimensions of such wall plates and or bands shall be as given in **Figure 9.6**.

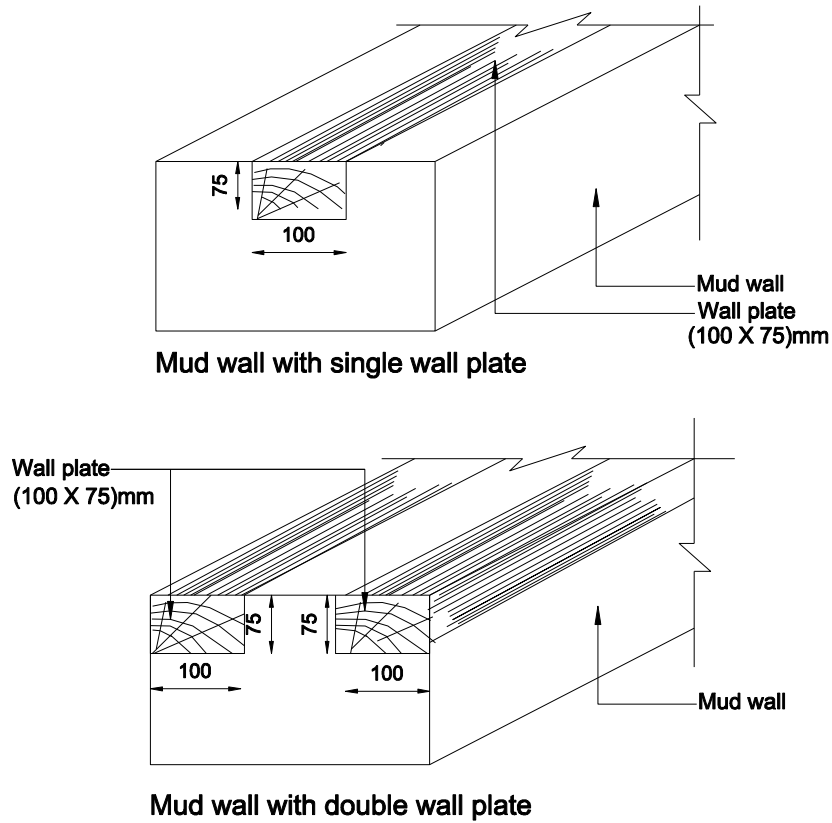

**Figure 9.6(a): Details of Fixing Wall Plates
(In areas where steel and concrete are not available)**

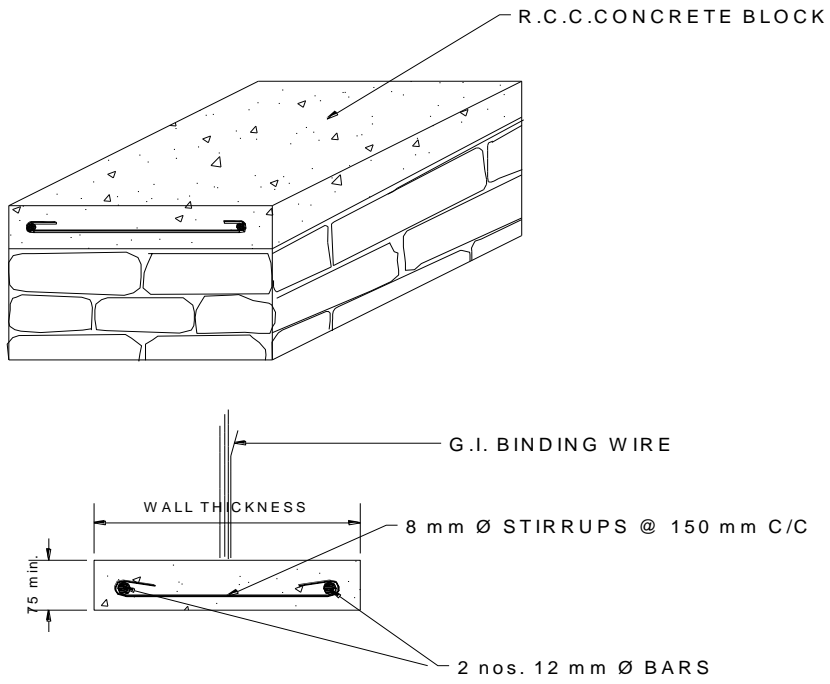

**Figure 9.6(b): Details of Fixing Wall Plates
(In areas where steel and concrete are available)**

9.1.4 Joists and Rafters

The joists/rafters shall be long enough to extend beyond supporting members such as walls and/or beams. The extended joists/rafters should have timber keys on both external and internal sides of both the supporting elements as shown in **Figure 9.7**.

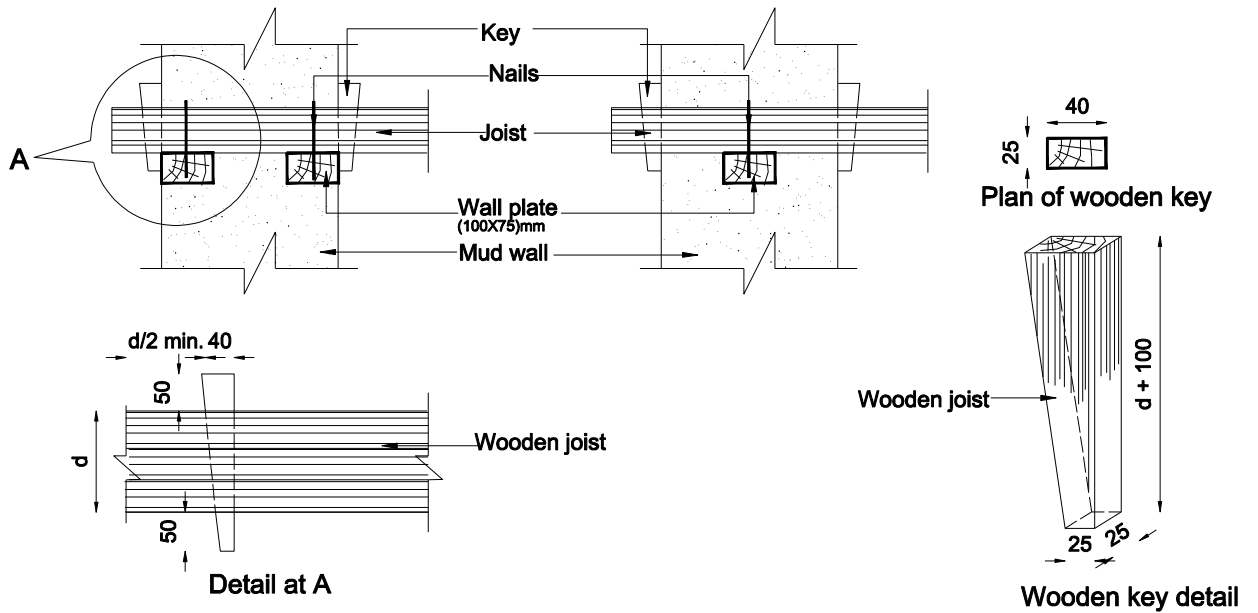

Fixing of joists

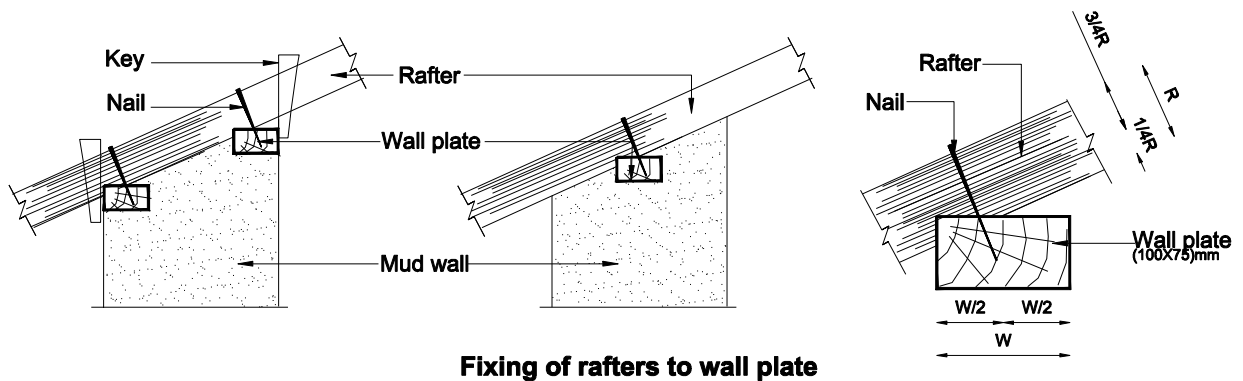

Fixing of rafters to wall plate

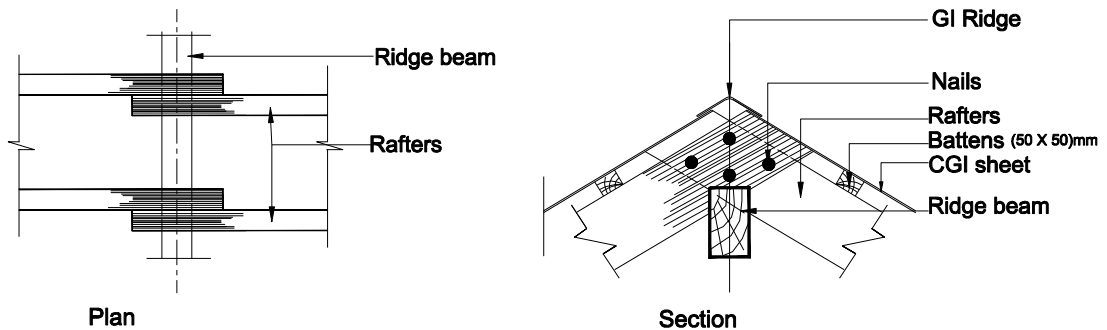

Fixing of rafters to ridge

**Figure 9.7(a):Details of Fixing Joists and Rafters
(In areas where steel and cement are not available)**

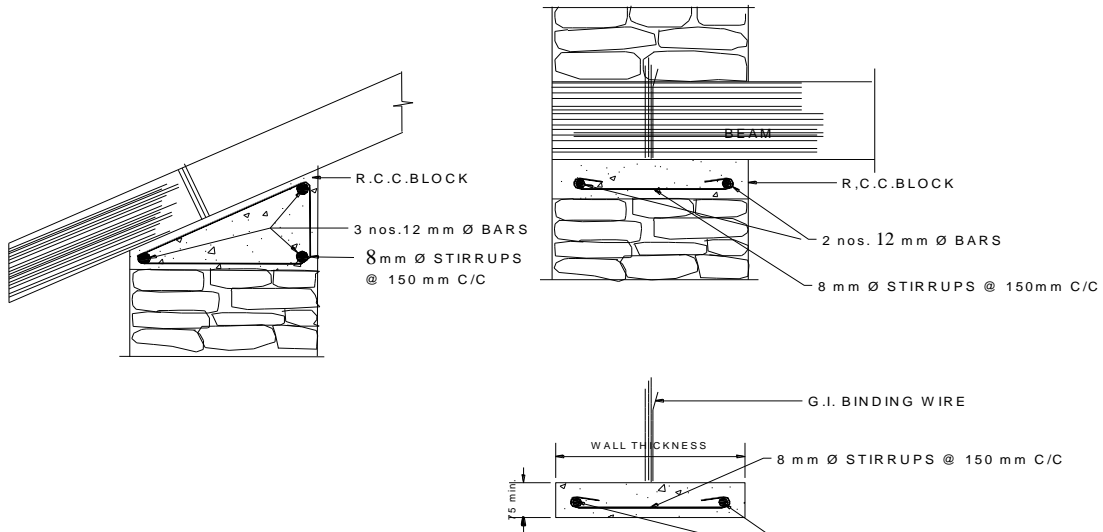

**Figure 9.7(b): Details of Fixing Joists and Rafters
(In areas where steel and cement are available)**

The joists/rafters should be rectangular in section and should never be laid with their wider surface horizontal. The minimum sizes of rafters for various spans shall be as tabulated in **Table 9.3**.

SPECIES	Dimension (DxB) FOR SPAN UPTO					
	1 m	1.5 m	2 m	2.5 m	3 m	3.5m
Hardwood	100*65	100*65	100*65	120*65	130*75	140*80
Softwood	140*75	140*75	140*75	170*90	180*90	200*100
Spacing (c/c)	≤0.5m	≤0.5m	≤0.5m	≤0.5m	≤0.5m	≤0.5m

Table 9.3: Minimum Depth (mm) of Joists and Rafters

9.2 Floor Finishing and Roof Covering

9.2.1 Bridging Materials

Using better bridging materials allows joists to be spaced wider apart which will not only reduce the construction cost, but also makes the building lighter. If chopped (split) wood or planks are used as bridging materials, they shall be nailed to each joist supporting them. If bamboo, reed, or any other material is used, it also shall be tied to the joists. Some of the simple connecting details of such materials are illustrated in **Figure 9.8**.

Half-cut bamboo placed as an inverted "U" over the joists makes the best low-cost bridging material.

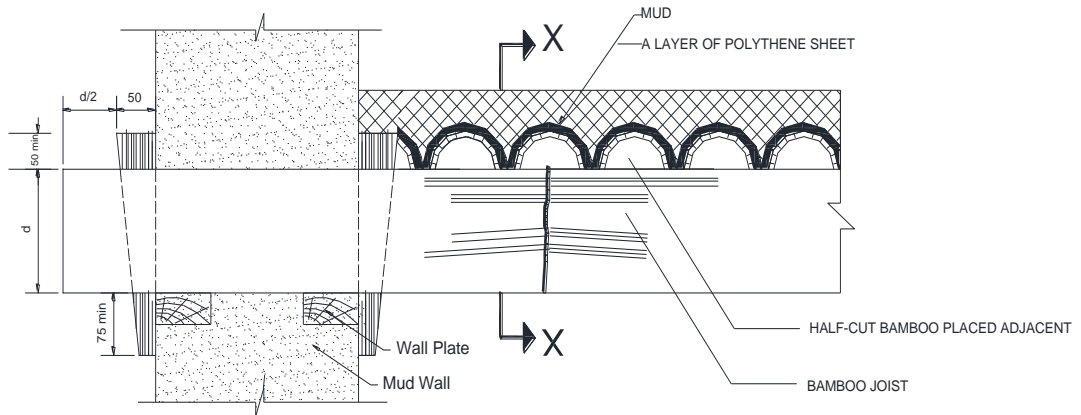

ELEVATION

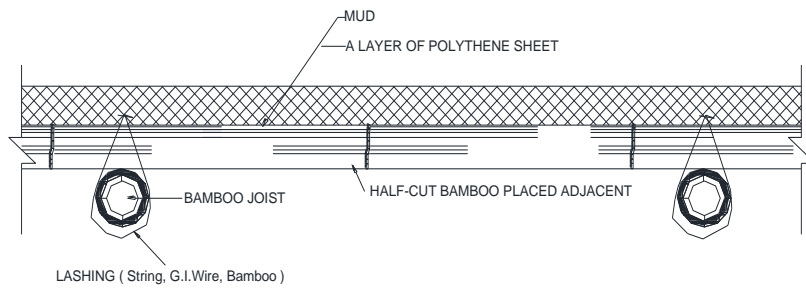

SECTION AT X-X

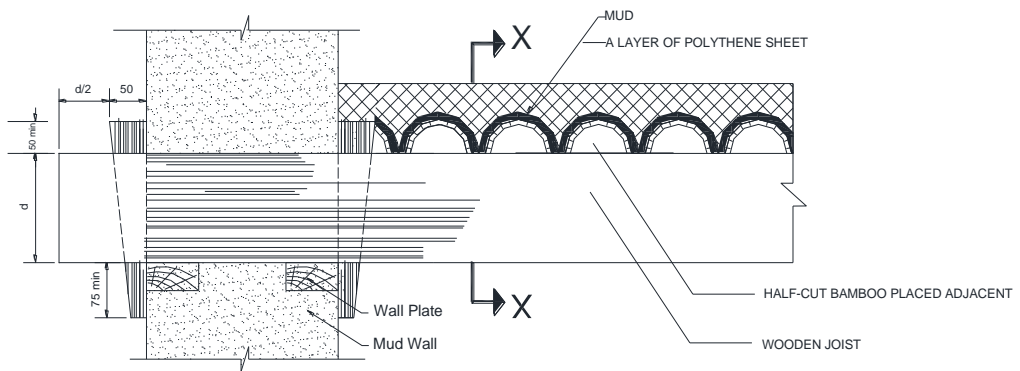

ELEVATION

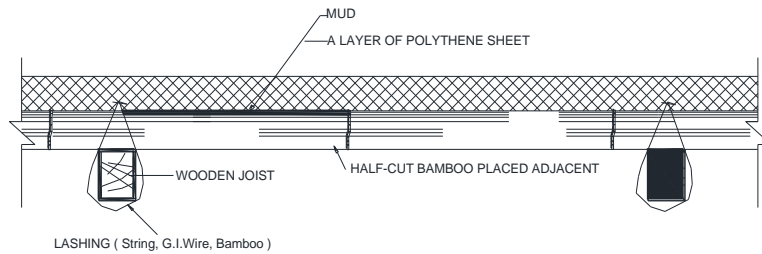

SECTION AT X-X

Figure 9.8: Details of Fixing Bridging Materials to Joists and Rafters

9.2.2 Floor Finishing

It is preferable to use better bridging materials between the joists to achieve a stiffer flooring. Timber planks and half-cut bamboos are examples of these. The fixing could be carried out as illustrated in **Figure 9.8**.

The mud layers used for the floor base and finish shall not be more than 75 mm thick in total.

9.2.3 Roof Covering

Stone slabs, slates and mud roofing make the building heavy. These elements should be avoided as far as practicable. Tiles or *jhingati* laid over a mud layer are another load-increasing factor and should be avoided. However, it may not be possible to avoid completely these elements owing to various constraints. Lighter options such as thin stone slabs and a thinner layer of mud are preferable.

9.2.3.1 Mud

Mud is widely used in the northwestern parts of Nepal. The general techniques practiced for making mud roofs consume high quantities of mud, resulting in heavy building. Mud roofs could be constructed as illustrated in **Figure 9.9**.

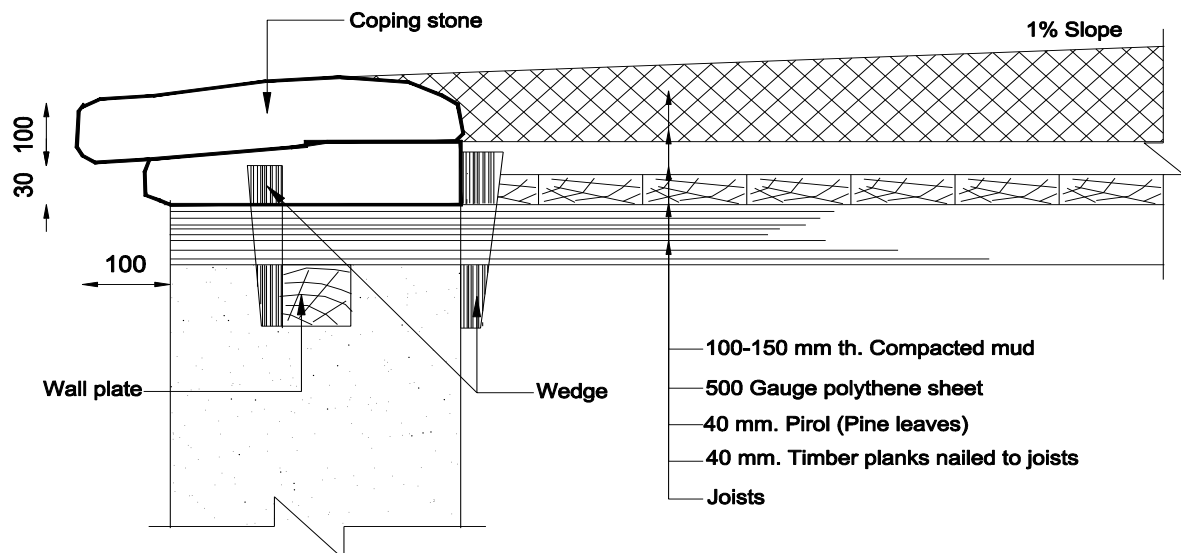

Figure 9.9: Details of Improved Mud Roofing

9.2.3.2 Thatch

Thatch is the lightest of all materials used for roof covering. A shorter life-span, leaking and vulnerable to fire are the main deficiencies of thatch which lead builders to opt for a better material. There are techniques available for making thatch durable and fire-retarding. Hence, improved thatch roofing shall be preferred to heavier materials such as stone slabs or slates. Thatch roofs could be constructed as illustrated in **Figure 9.10**. Thatch roofs shall be made fire-retarding and water-repelling by method given in **Appendix 2**.

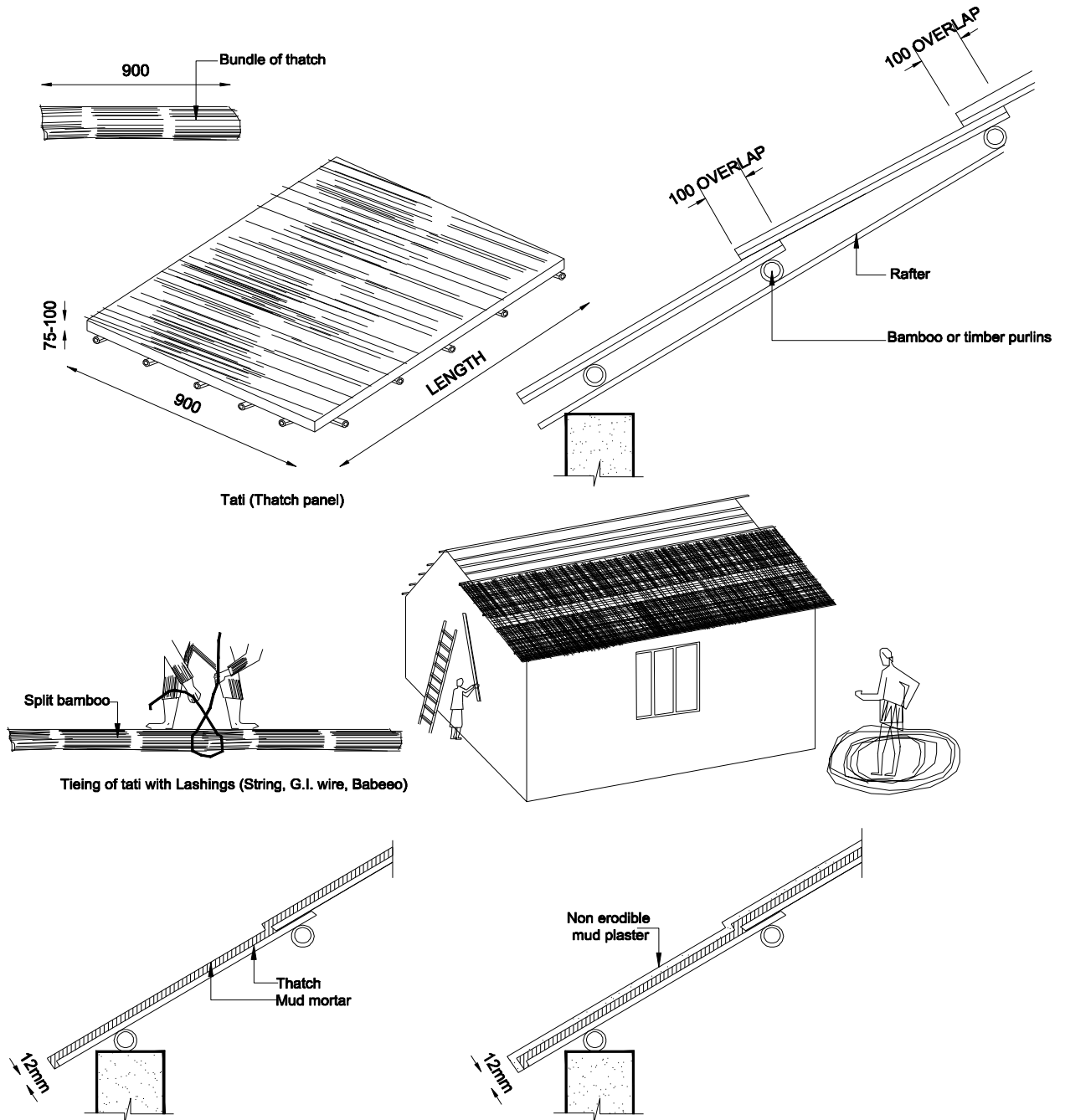

Figure 9.10 : Details of Improved Thatch Roofing

9.2.3.3 Stone Slabs

Only thinner slabs shall be used for roofing. A minimum overlap of 75 mm shall be provided on all sides. They should be properly tied to the purlins and rafters as illustrated in **Figure 9.11**

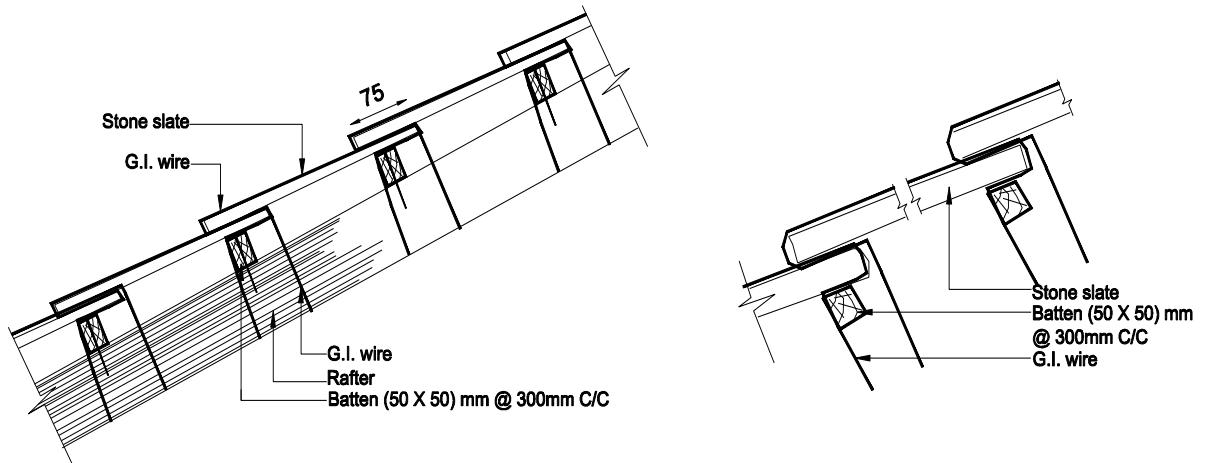

Figure 9.11: Details for Anchoring Stone Slabs

9.2.3.4 MCR Tiles

Micro roofing (MCR) tiles are becoming popular in many parts of the country. These tiles have projected binding wires embedded into the tiles for anchoring. All the tiles should be properly tied with these protruding wires to the battens and purlins, as shown in **Figure 9.12**.

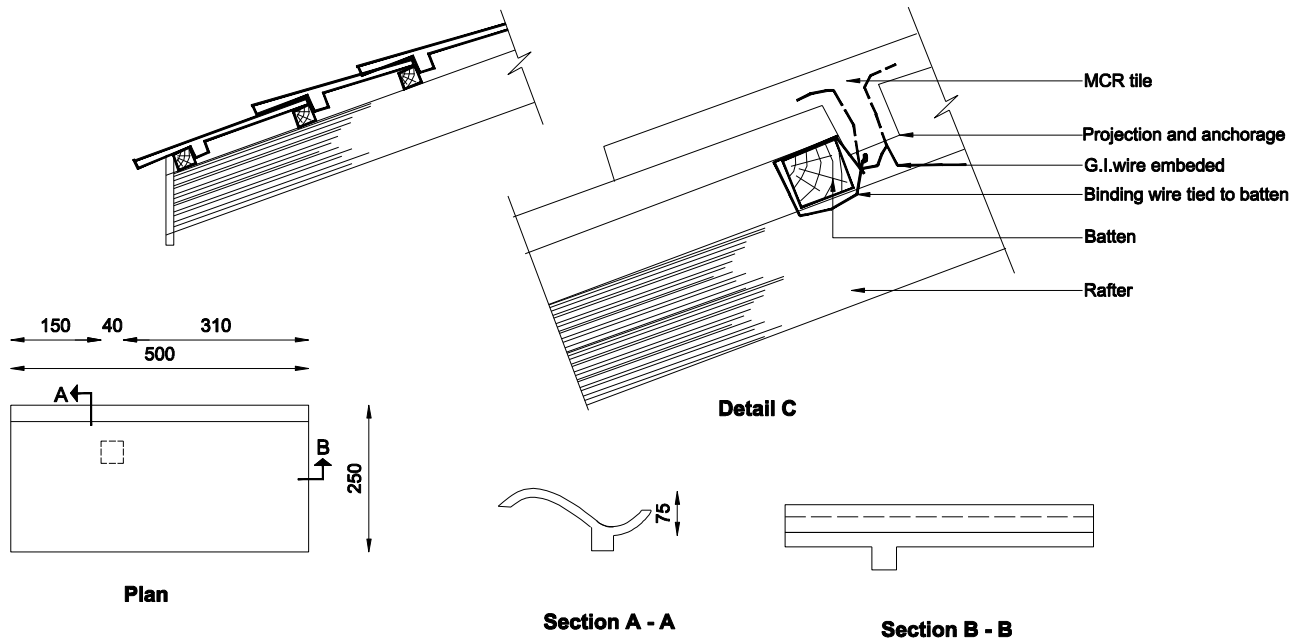

Figure 9.12: Details of Fixing MCR Tiles

9.2.3.5 Clay Tiles

Only well-burnt clay roofing tiles of good quality shall be used for roofing. All the tiles shall be well-anchored on the battens. The details given in **Figure 9.13** could be adopted for fixing clay tiles.

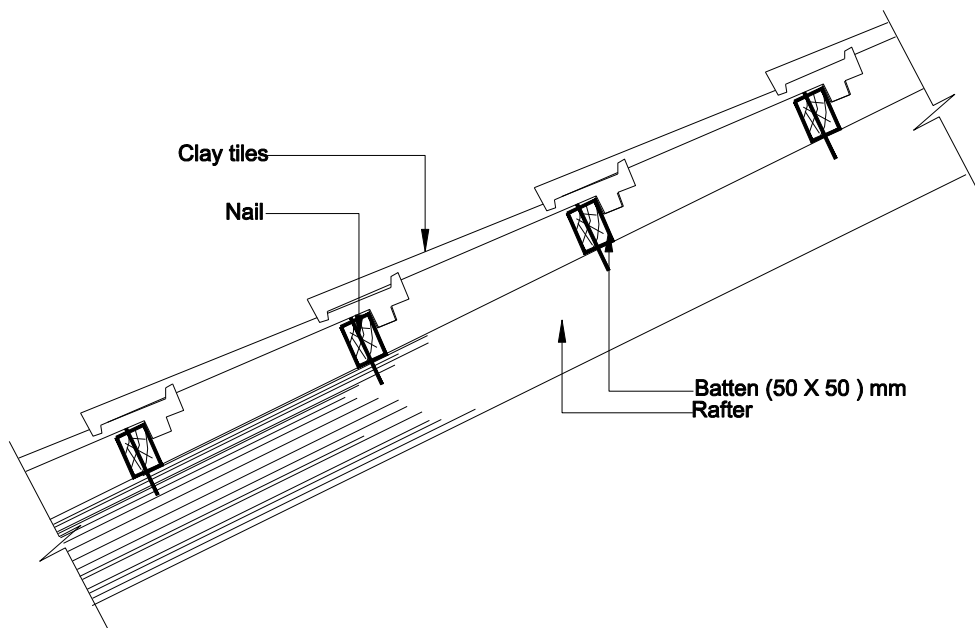
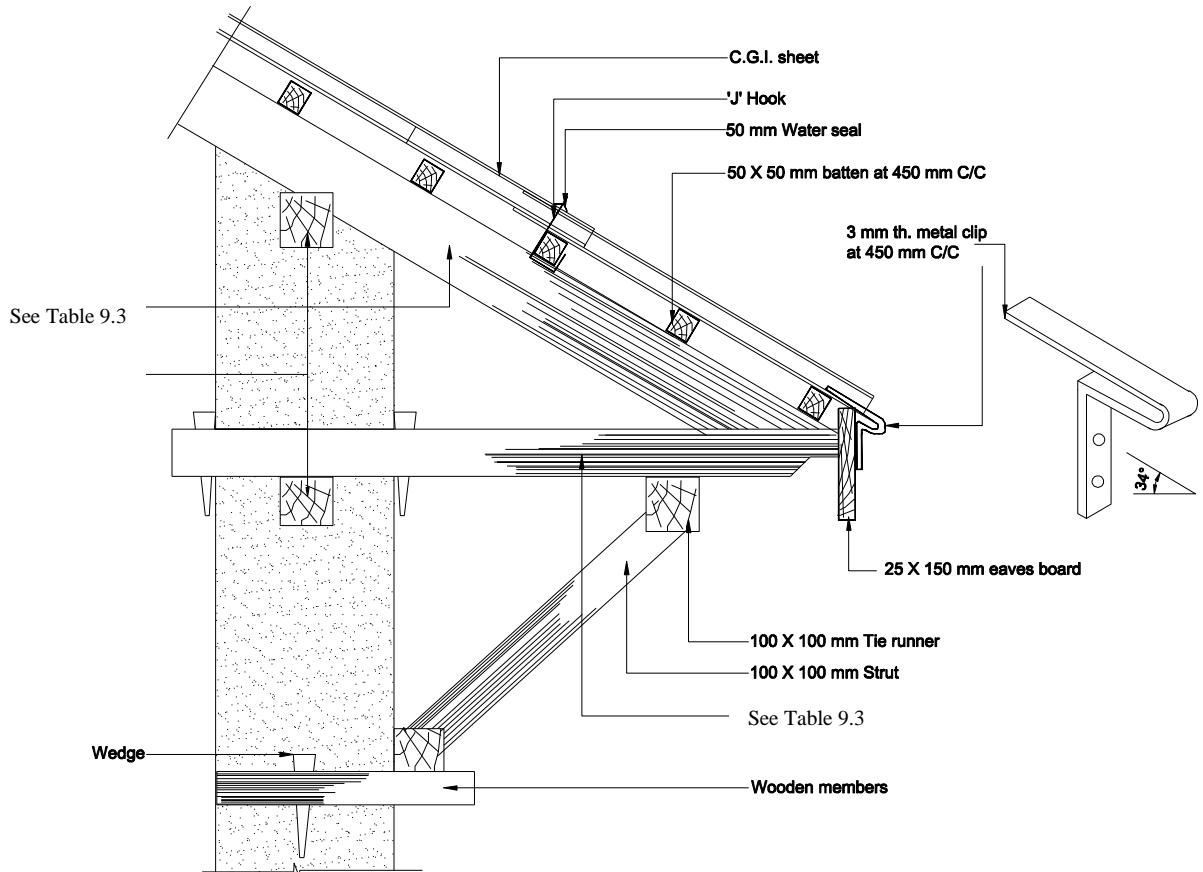

Figure 9.13: Details of Fixing Clay Tiles**9.2.3.6 CGI Sheets**

Corrugated galvanized iron (CGI) sheets are very popular in all parts of the country, except in the high mountains. These sheets shall be properly anchored to each purlins/battens that support them. The details could be as illustrated in **Figure 9.14**.

**Figure 9.14: Details for Fixing CGI Sheets****9.3 Bamboo for Flooring and Roofing**

Only treated bamboo shall be used for structural elements. The bamboos shall be straight and uniform without any defects.

9.3.1 Bamboo Flooring

Bamboo flooring could be made as illustrated in **Figure 9.15**.

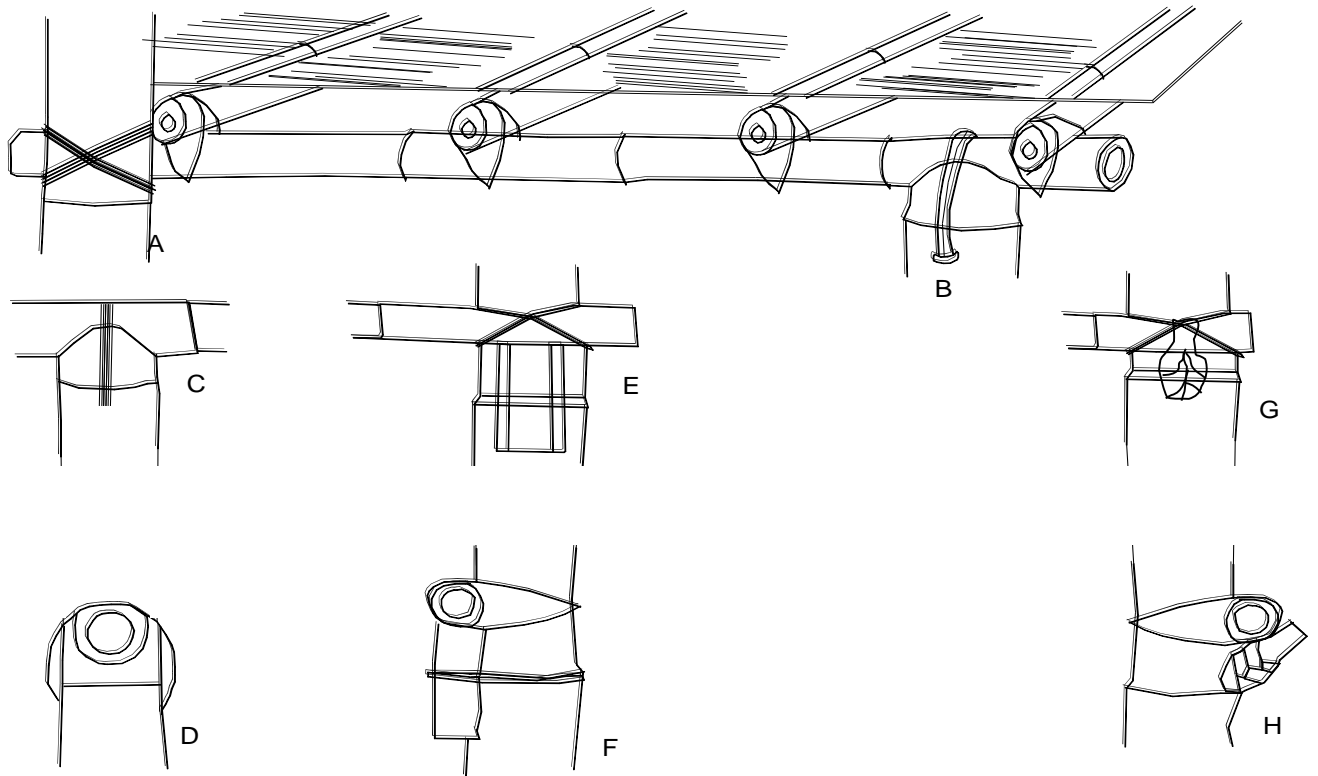

- A, FITTING AND BINDING CULMS AT JOINTS IN ROOF AND FRAME
 B, FITTING AND SECURING BAMBOO BOARDS OF FLOOR
 C, D, SADDLE JOINT
 E, F, USE OF INSET BLOCK TO SUPPORT HORIZONTAL LOAD SHARING ELEMENTS
 G, H, USE OF STUMP OF BRANCH AT NODE OF POST TO SUPPORT HORIZONTAL LOAD BEARING ELEMENTS

Figure 9.15: Details of Bamboo Flooring

9.3.2 Bamboo Roofing

Bamboo roofing can be made in two ways. The first method is for a simple roof, the details of which could be made as illustrated in **Figure 9.16**.

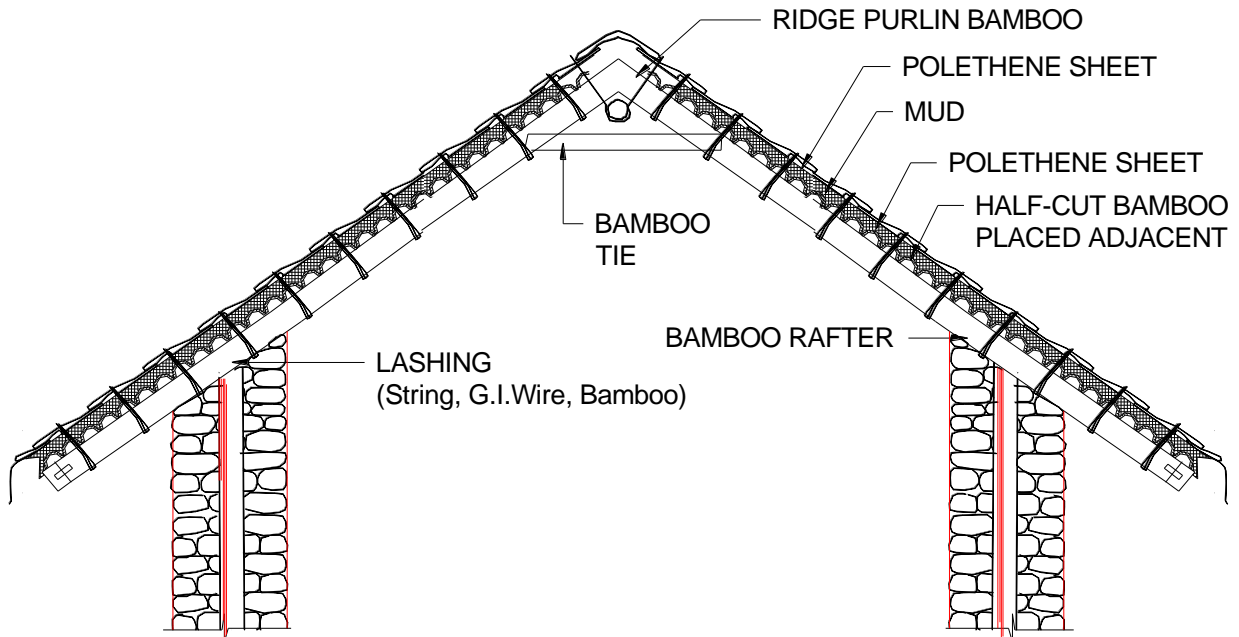

Figure 9.16: Details of Simple Bamboo Roofing

The second method involves making a simple truss out of bamboo. The construction of bamboo trusses shall be done as illustrated in **Figure 9.17**.

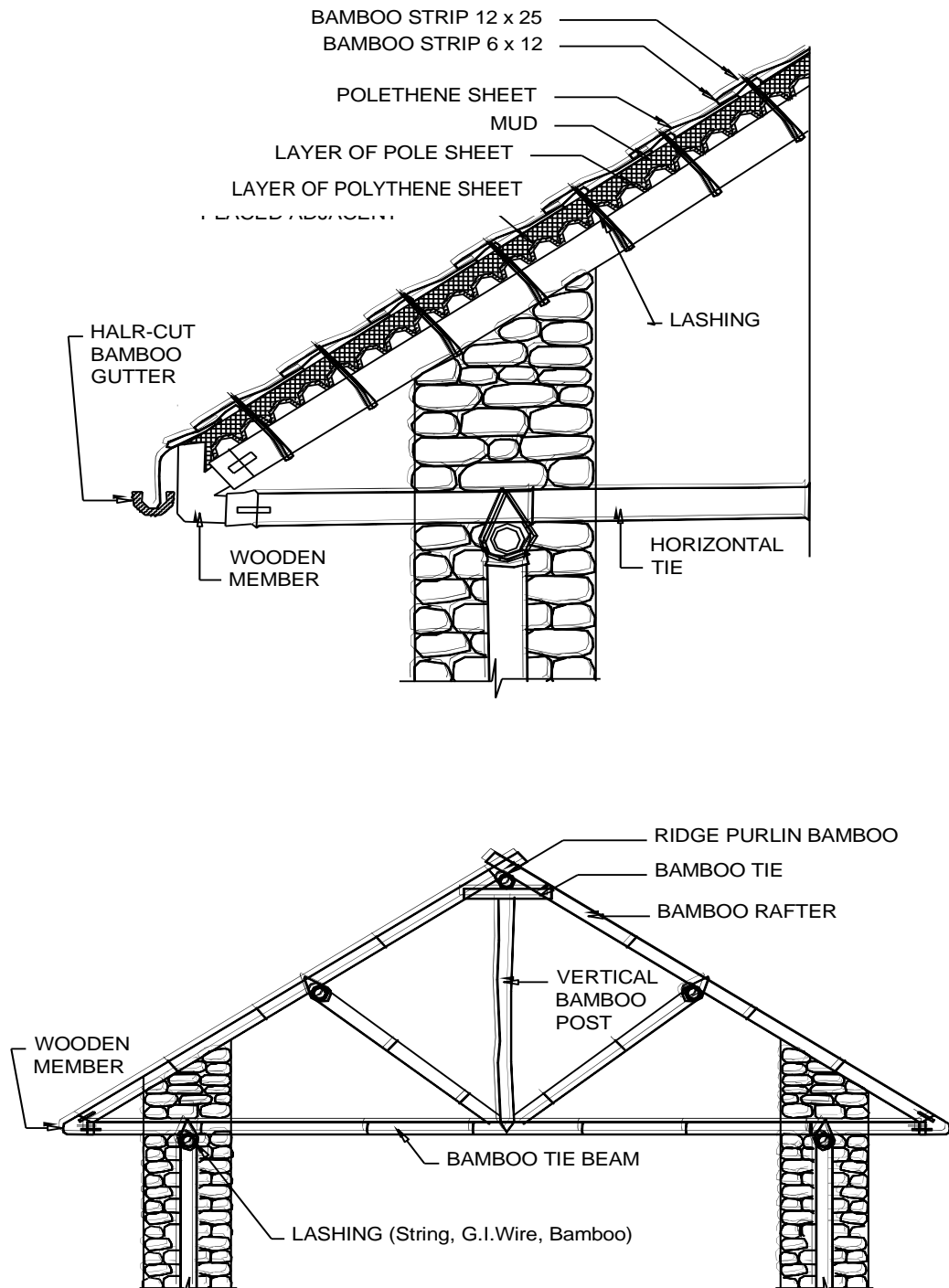

Figure 9.17: Details of Trussed Bamboo Roofing

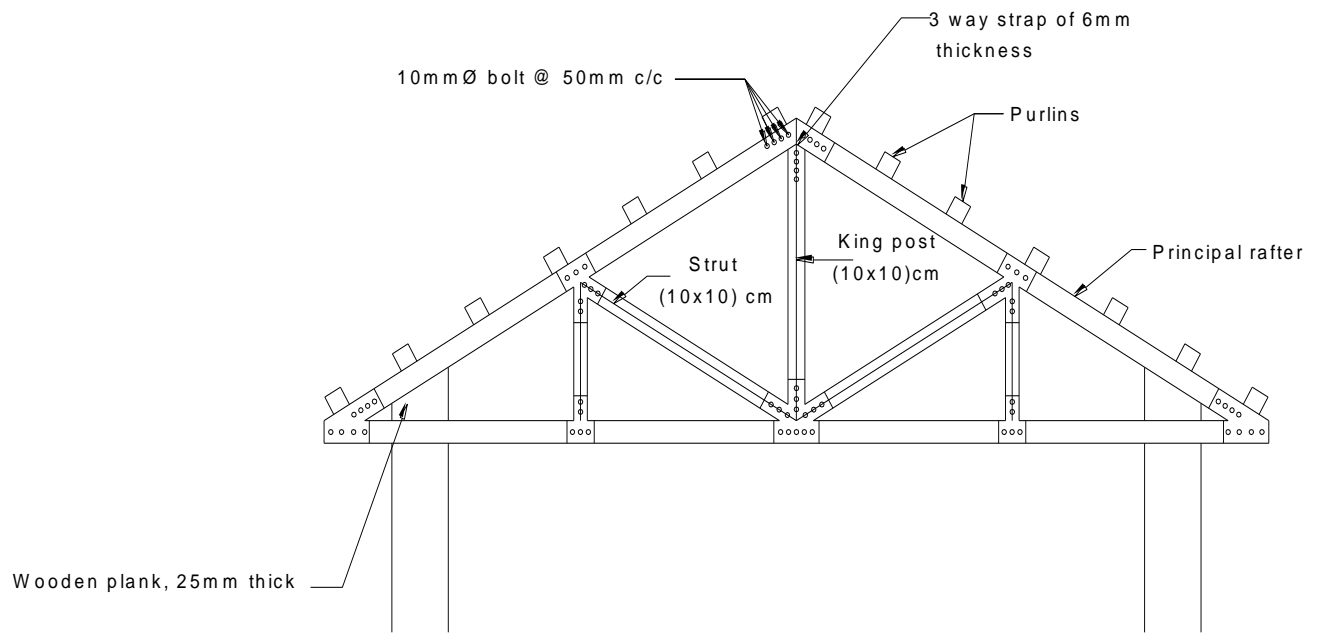
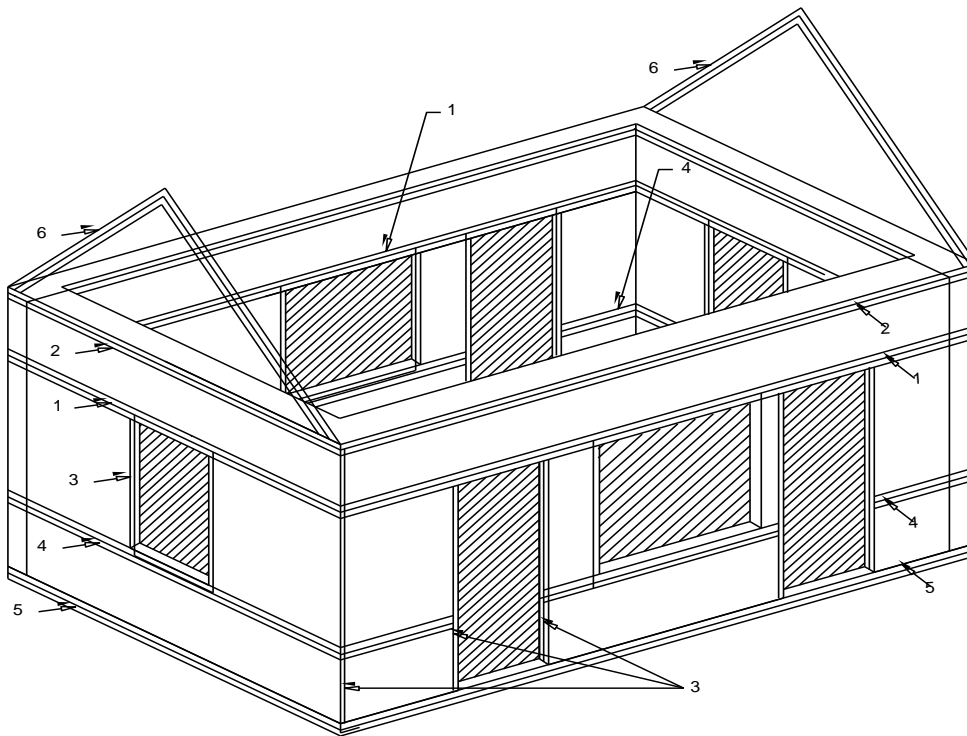

Figure 9.18: Details of Wooden Roof Trusses

10 Seismic-Resistant Components

There are number of components which contribute to the enhanced safety against earthquake forces. These elements shall be incorporated in all buildings. The details are given hereunder.

An overall view of seismic-resistant components in a building is shown in **Figure 10.1**.



- 1 - Lintel Band
- 2 - Roof Band (only for pitched roofs and under roofs and floor)
- 3 - Vertical steel.
- 4 - Sill Band.
- 5 - Plinth Band.
- 6 - Gable Band.

Figure 10.1 An Overall View of a Building with Seismic-Resistant Components

10.1 Vertical Reinforcement

No masonry wall shall be constructed without vertical reinforcement. The materials used for vertical reinforcement shall depend upon the availability of suitable materials in the locality. Steel bar, which is the best, is not available in most of the rural Nepal. Bamboo is another potential material for vertical reinforcement. The size of vertical bamboo reinforcement shall be more than 80mm in diameter having thickness of at least 10mm. Timber can also be used. In order to enhance the bonding between vertical bamboo post and wall, lime, as a better bonder than mud, shall be applied at every corner and junction of wall. Long dressed stones (say 450mm) shall be laid at every corner and junction of wall where stone masonry is provided. The details for using each of these materials as vertical reinforcement should be as presented hereunder.

Vertical reinforcements shall be located at all corners and junctions of a wall. It shall start from the foundation and continued to the roof band.

10.1.1 Bamboo

The details for using bamboo as vertical reinforcing could be as illustrated in **Figure 10.2**.

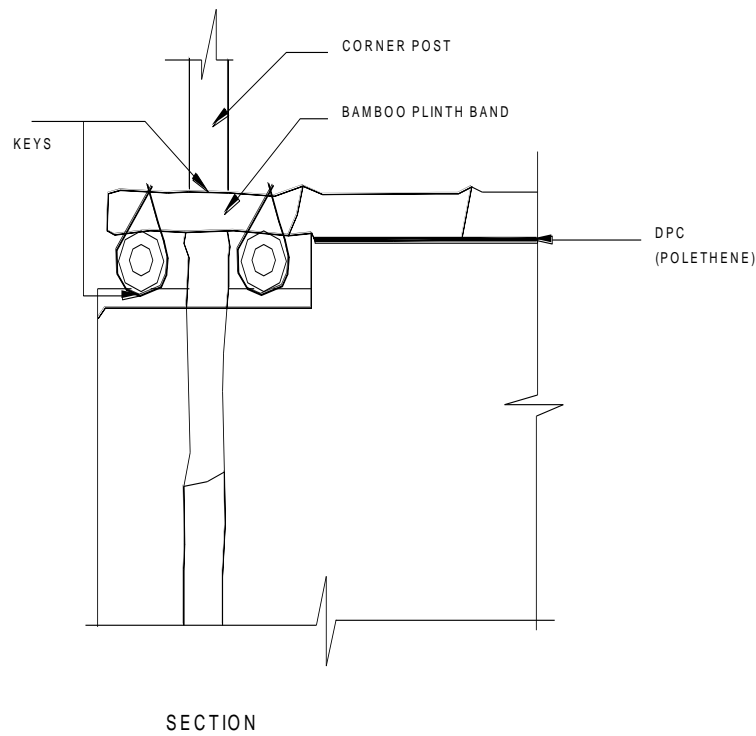

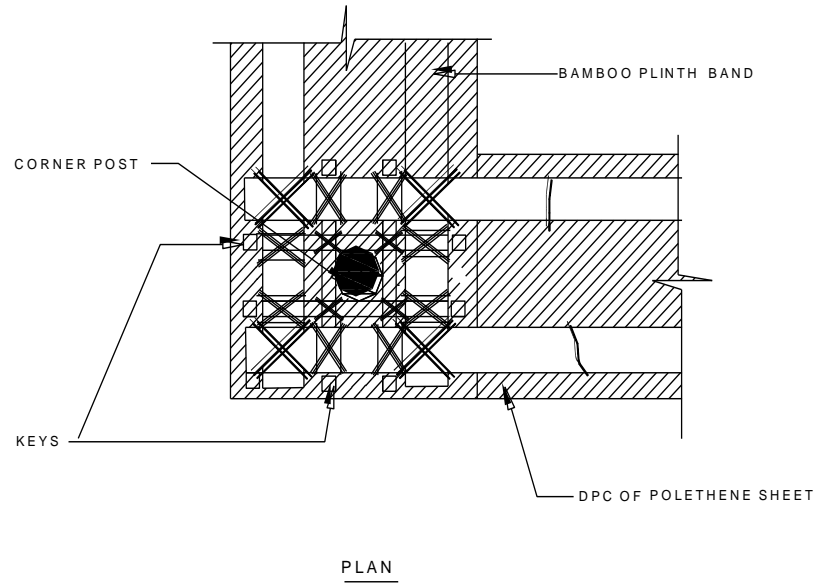

Figure 10.2 Bamboo as Vertical Reinforcement

10.1.2 Timber

It is difficult to find a single timber long enough to span between the foundation and the roof. Dovetail joints shall be used to connect the different timbers to form a single unit. The details of providing such vertical reinforcement could be as illustrated in **Figure 10.3**.

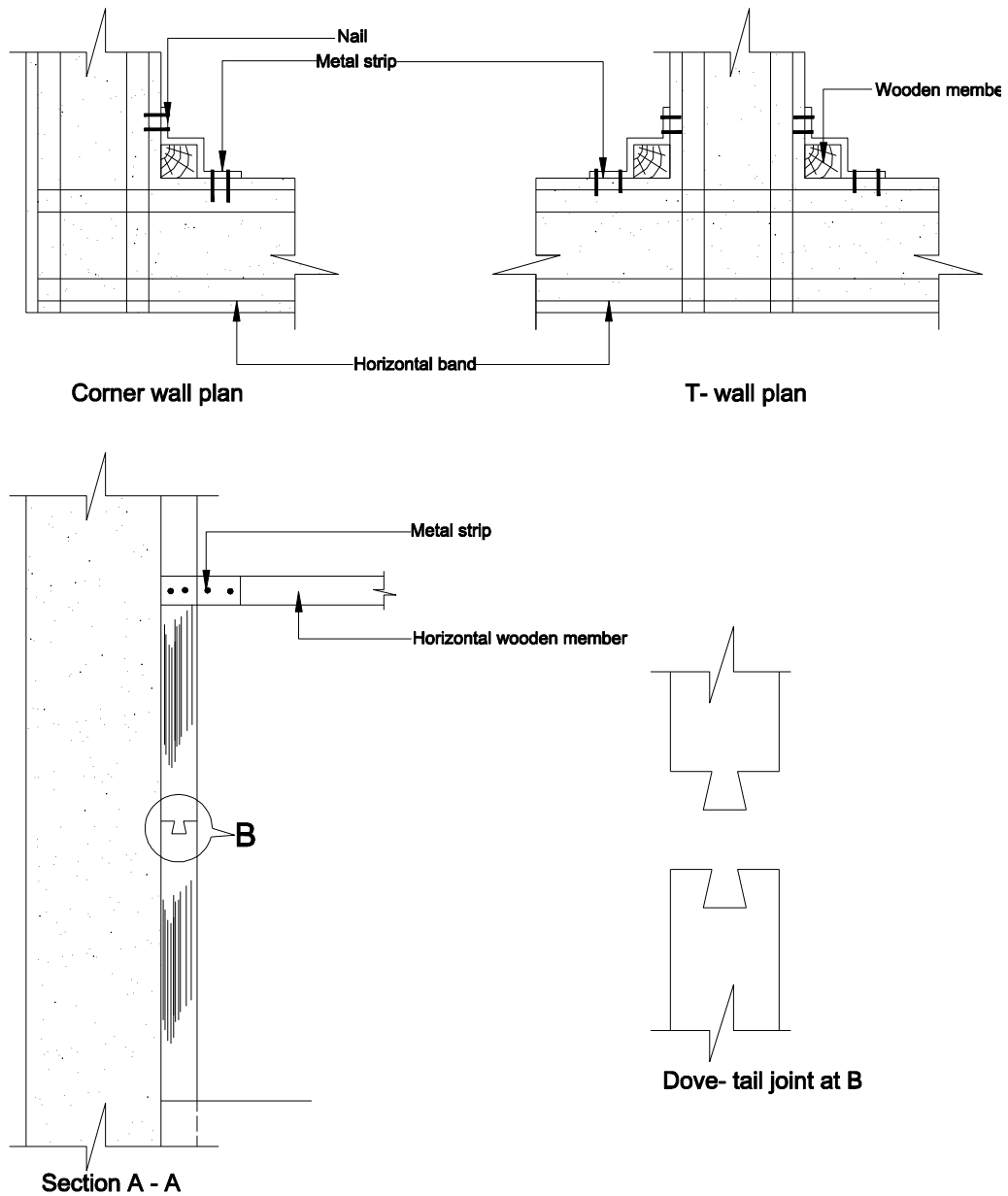
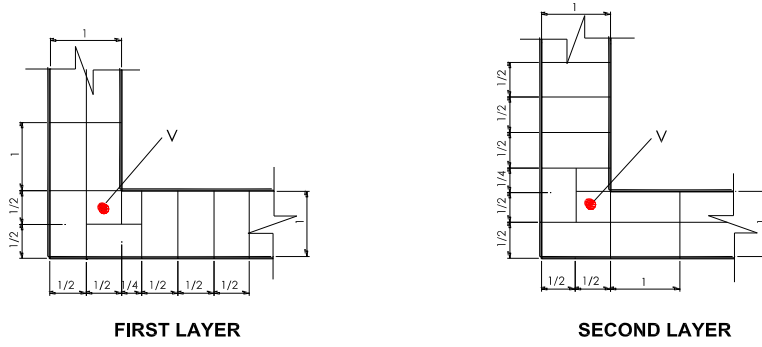

Figure 10.3: Timber as Vertical Reinforcement

10.1.3 Steel

In areas where steel and concrete are available, steel can be used to provided vertical reinforcement and it is usually the most effective. The steel bars shall be placed at all corners and junctions and if the vertical opening of the wall is more than 50 % of the wall height, vertical reinforcements shall also be provided in the jambs of the openings. The use of steel as vertical reinforcement shall be as shown in the **Figure 10.4**.The numbers of bars to be provided shall be as given in **Table 10.1**.



CORNER JUNCTION DETAILS FOR ONE BRICK WALL FOR PROVIDING VERTICAL STEEL.

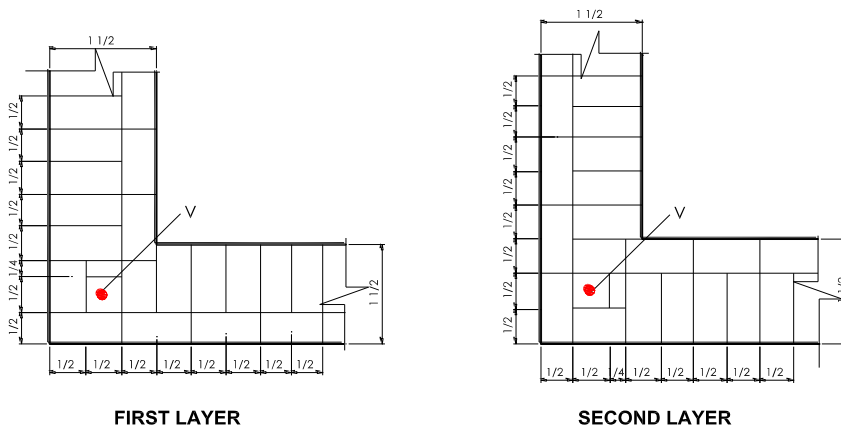

CORNER JUNCTION DETAILS FOR ONE AND HALF BRICK WALL FOR PROVIDING VERTICAL STEEL.

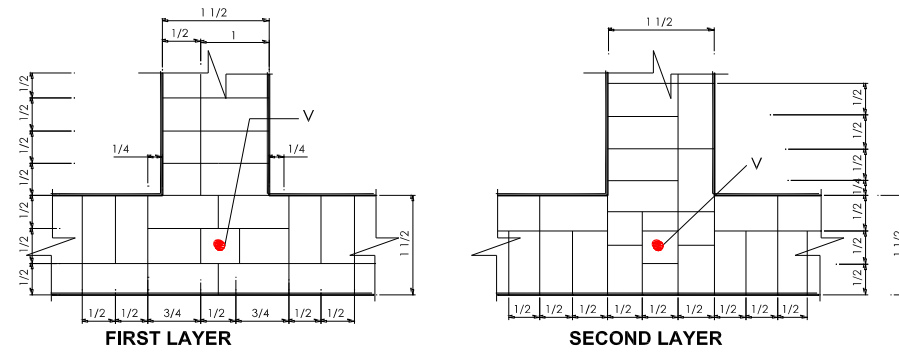

T- JUNCTION DETAILS FOR ONE AND HALF BRICK WALL FOR PROVIDING VERTICAL STEEL.

1/4, 1/2, 1 and 1 1/2 indicates: 1/4 Brick wide, 1/2 Brick wide, 1 Brick wide, 1.5 Brick wide etc.,
 V - Vertical Bar

Figure 10.4 (a): Steel for Vertical Reinforcement

The installation of a vertical bar in stone masonry can easily be effected by using about 750mm long and 75 mm diameter pipe casing around which the masonry is built to a height of 600 mm. The pipe is kept loose by rotating it during masonry construction. Then the casing is raised up and the cavity filled around the bar with concrete (1:2:4) as shown in **Figures 10.4 (a)** and **10.4 (b)**. The concrete will not only provide a bond between the steel and the masonry, but it will also protect the bar from corrosion.

The jamb steel shall be taken from the footing up to the lintel band and anchored into it.

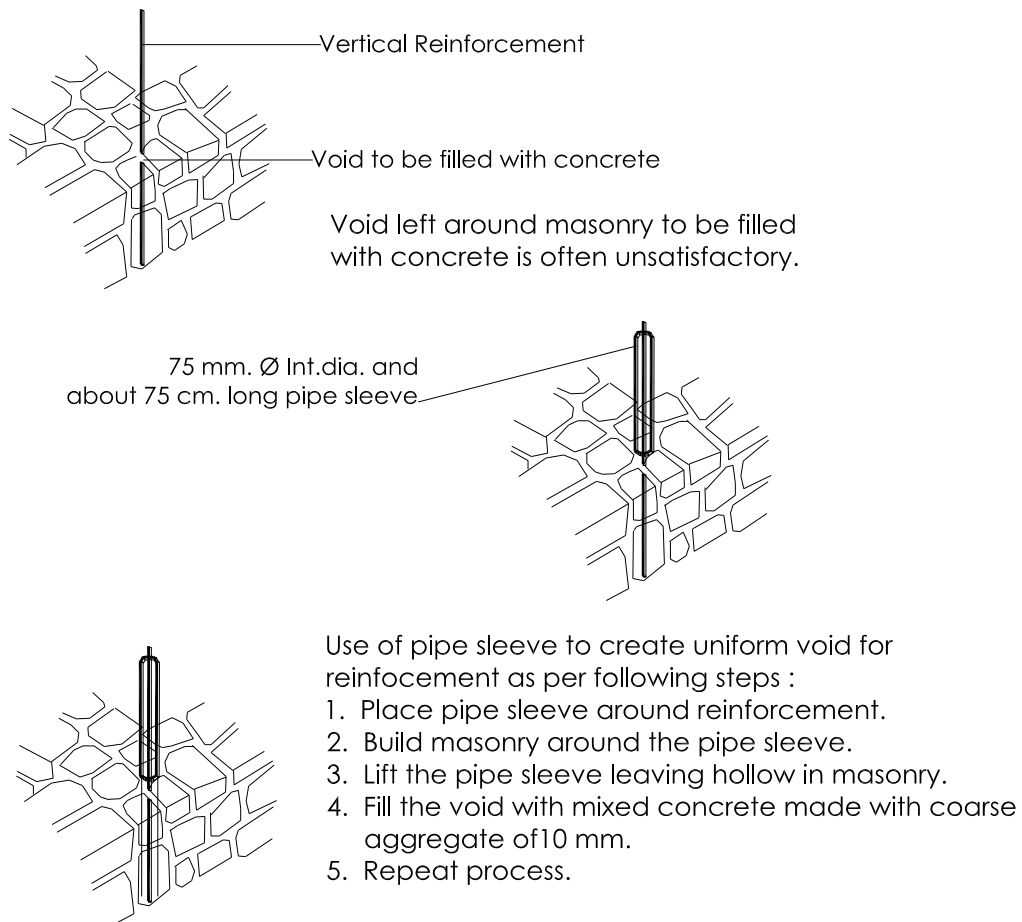
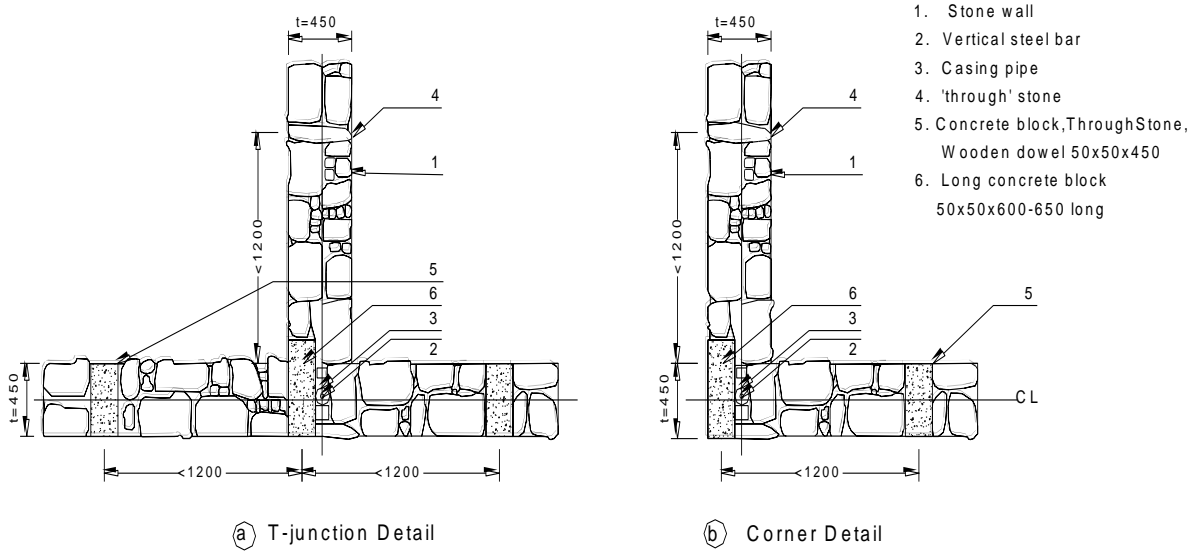

Figure 10.4 (b): Vertical Reinforcement in Rubble Stone Masonry



$t= 450$ for mud mortar

Figure 10.4(c): 'Through' Stone or Bond Elements in Stone Walls in Mud Mortar

No of Storey	Floor	Dia. of single Fe-415 bars at each:	
		Corners and Junctions	Jambs of opening#
One	Ground	12	12
One plus Attic	Attic	12	12
	Ground	12	
Two*	First	12	12
	Ground	16	12
Two* (plus Attic)	Attic	12	12
	First	12	12
	Ground	16	12

Notes :

**Two-storey buildings with load-bearing stone masonry of random rubble or half-dressed stone are not recommended in soft soil.*

** The vertical steel in the jamb shall be provided where the opening of the wall is more than 50 % of the wall height.*

Table 10.1: Recommended Vertical Steel at Critical Sections

10.2 Horizontal Bands

Horizontal bands are pre provided to create box effects and to impart horizontal bending strength in them. Reinforced concrete band is the best material for horizontal bands. However, this is not practical in many rural parts of Nepal owing to many supply constraints. Therefore, bamboo and timber should be used as alternatives. Such bands

shall be located at least at the plinth, sill, and lintel levels of the building. They shall be made continuous throughout wall with proper connections, and they shall be tied properly with the vertical reinforcement at different levels. Details of the use of various materials for these horizontal bands are given below

10.2.1 Bamboo Band

An assemblage of two parallel bamboo length connected by struts shall be made wide enough to cover the entire thickness of the wall to create a horizontal band. The details of constructing such a bands shall be as illustrated in **Figure 10.5(a) and 10.5(b)**.

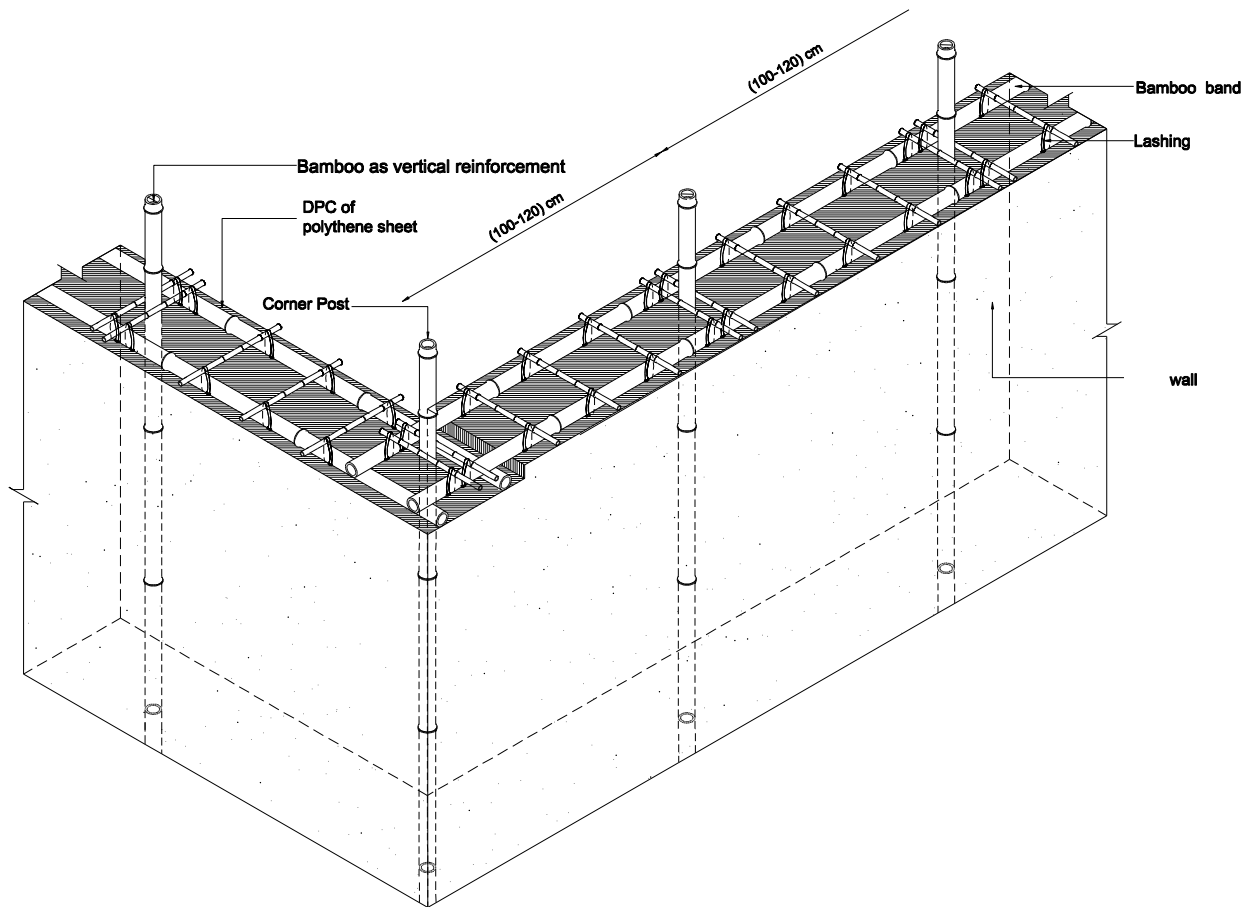
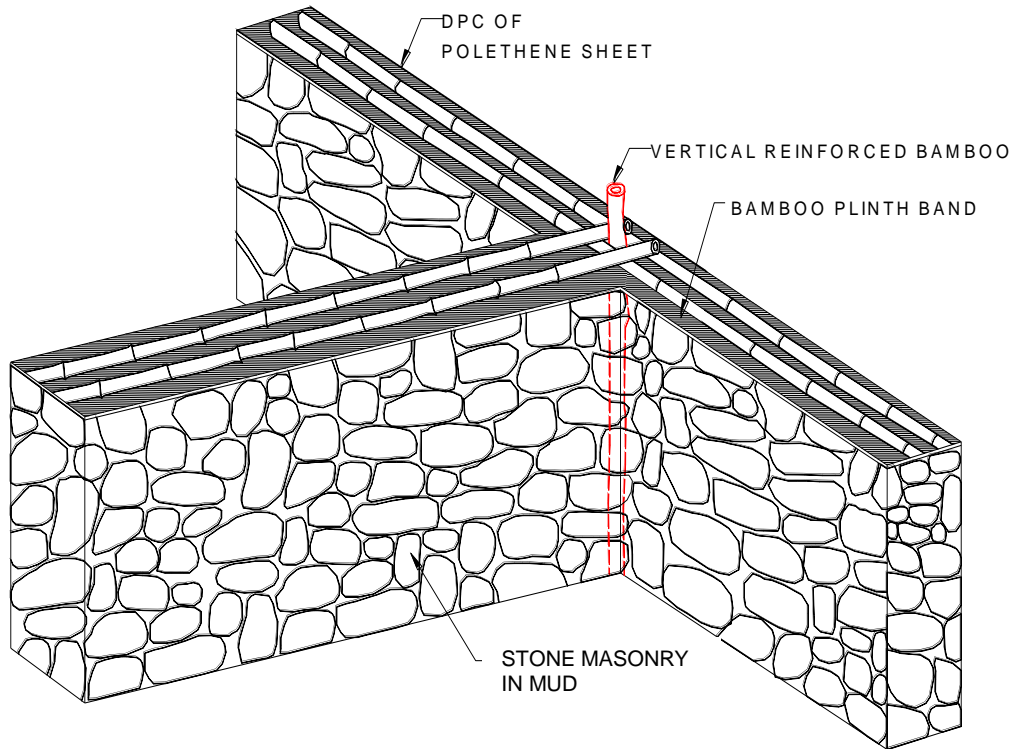

Figure 10.5(a): Bamboo for Horizontal Band



BAMBOO REINFORCED WALL

Figure 10.5(b): Bamboo for Horizontal Band

10.2.2 Timber Band

A timber band can be constructed in a similar manner to the bamboo band. The details could be as illustrated in **Figure 10.6(a) and 10.6 (b)**.

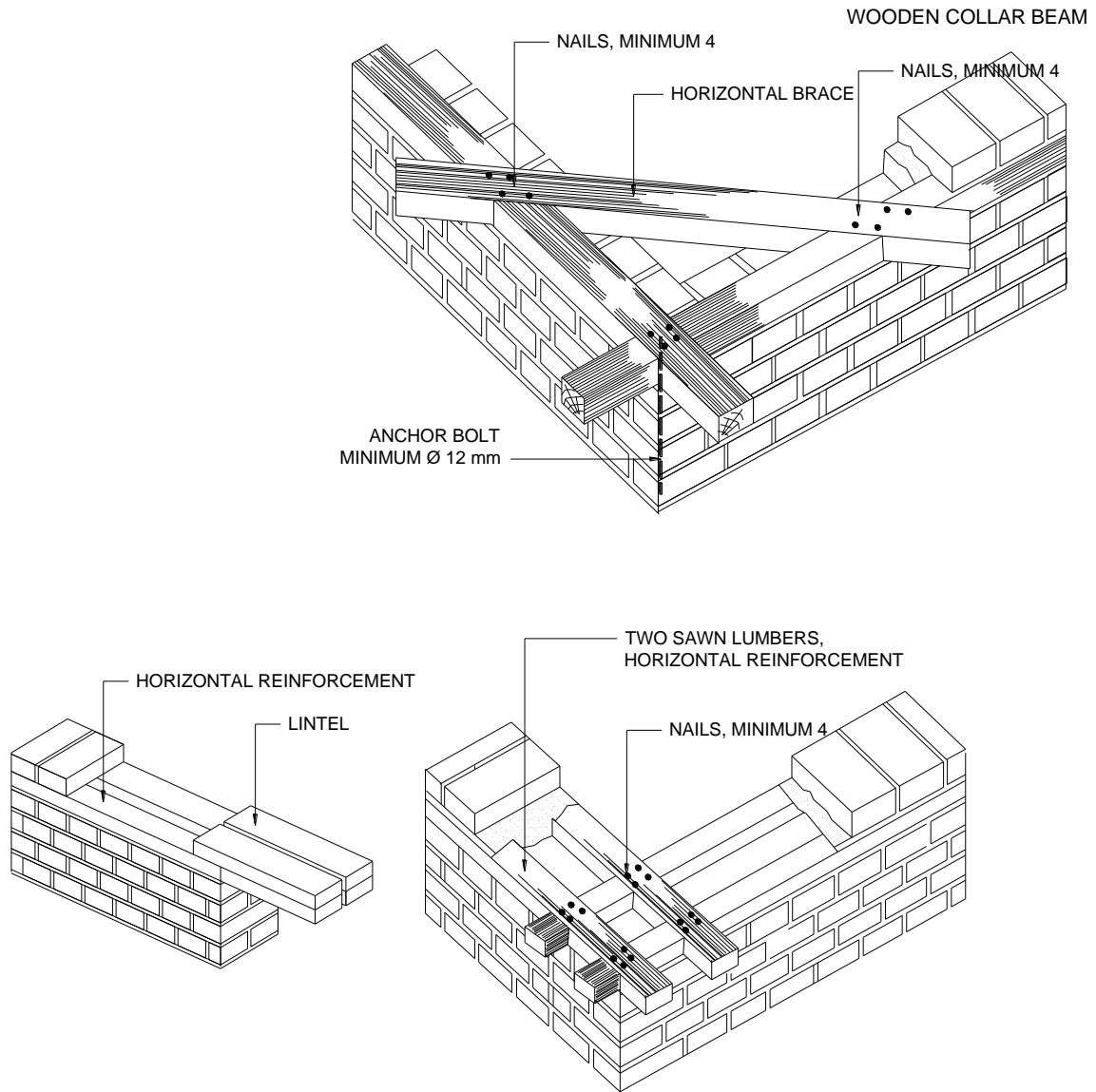
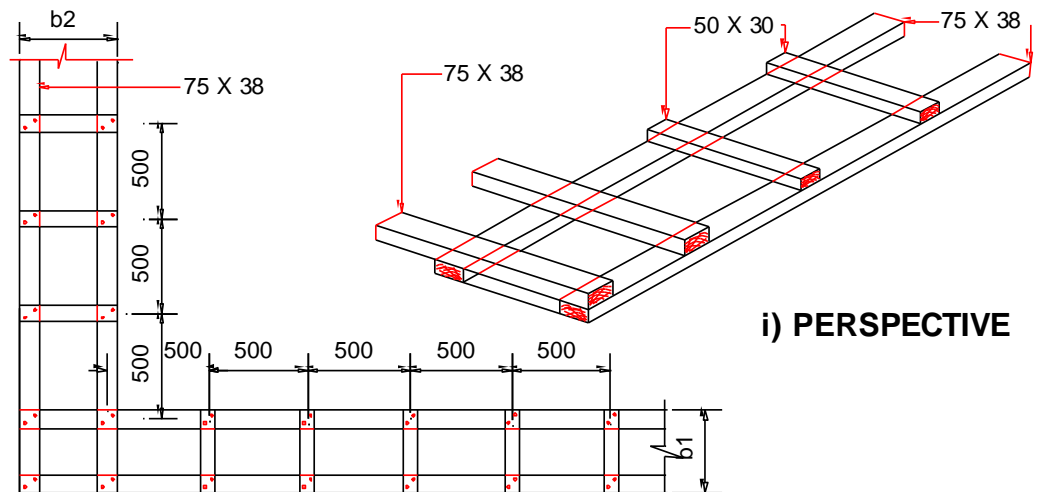
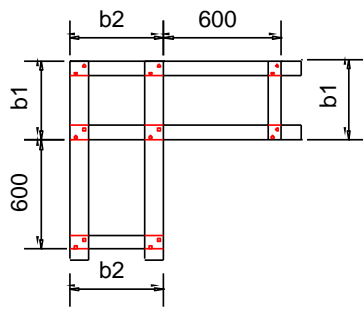

Figure 10.6 (a): Timber for Horizontal Band



Lintel-Level Wooden Band on all Load-Bearing Walls



i) WOOD DOWEL AT CORNER OF WALL

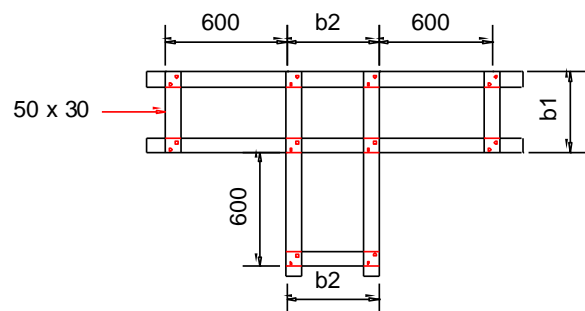

ii) WOOD DOWEL AT T-JUNCTION OF WALL AT ABOUT 900 ABOVE FLOOR LEVEL

Figure 10.6 (b): Details of Timber Reinforcing at Corners and T-Junctions

10.2.3 Reinforced Concrete Band

Horizontal bands of steel and concrete shall be provided. Such bands shall be provided at plinth, sill, lintel, floor and roof levels. The details of the reinforcement in these bands are as shown in **Figure 10.7**.

Band	RC band minimum thickness	Min. No. Of bars	Min. Diameter of Bars (mm)
Plinth	150mm ^{*1}	4	12
Sill	75mm	2	10
Lintel	75mm ^{*2}	2	12
	150mm ^{*2}	2 2	10(top) 12(bottom)
Roof	75mm	2	12
Dowel (Stitch)	75mm	2	8

Note:

- **1: Plinth band thickness can be reduced to 75mm in case of hard soil, reinforced with 2-12mm dia bars.*
- **2: Where opening width do not exceed 1m and masonry height above opening do not exceed 0.9m, 75mm lintel is sufficient. In such case, longitudinal reinforcement shall be placed at bottom face maintaining 25mm cover from bottom. For opening width upto 1.5m and masonry height above opening upto 1.2m, 150mm lintel band is necessary.*
- *The specified bar is for High Strength Deformed Bars-Fe415. Mild steel bar of equivalent area can also be used as steel-reinforcement.*
- *Additional longitudinal bars shall be provided at the middle of each layer if the width of the wall exceeds 250mm such that spacing of these bars do not exceed 250mm.*
- *Width of the RC band is assumed to be the same as the thickness of wall. A cover of 25 mm from face of wall shall be maintained.*
- *The vertical thickness of RC band may be kept minimum 75 mm where two longitudinal bars are specified and 150 mm where four longitudinal bars are specified.*

- *Concrete mix to be 1:2:4 by volume of having M15 grade cube crushing strength at 28 days.*
- *The longitudinal bars shall be held in position by steel stirrup of 8 mm diameter spaced at 150 mm apart.*

Table 10.2: Recommended Steel in Reinforced Concrete Band

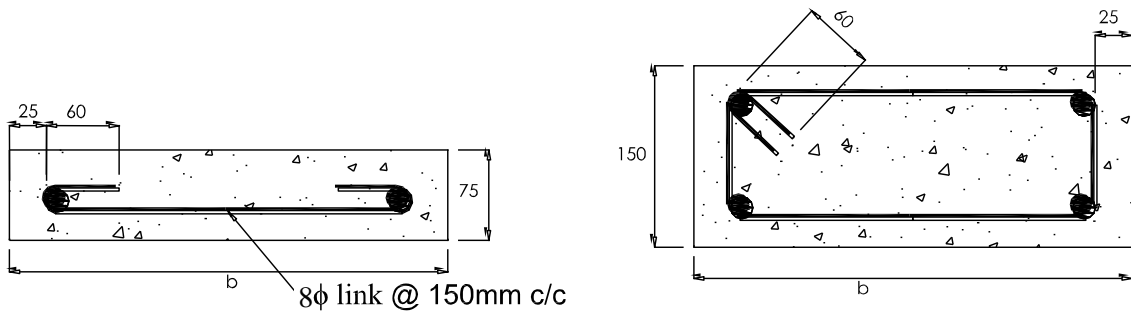

(a) Cross section of R.C.C band for two bars and four bars

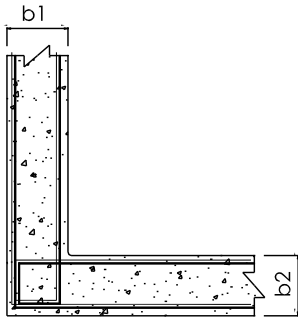

or

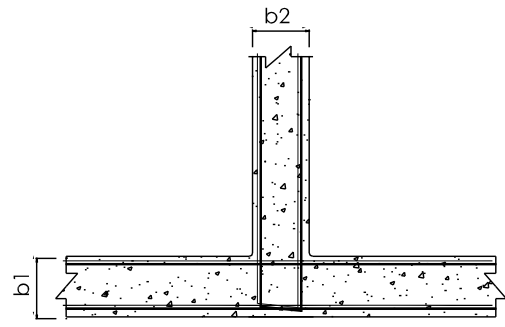
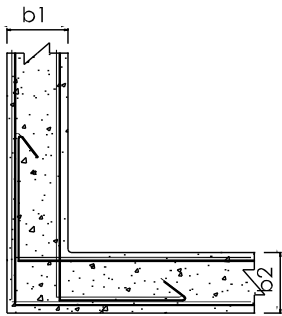

or

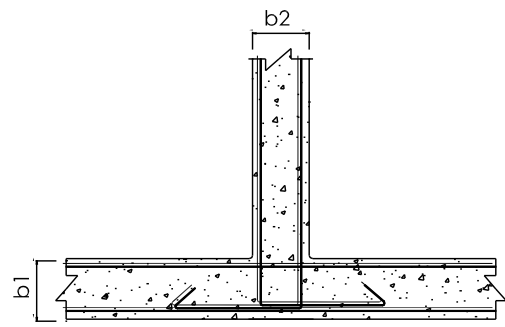

or

$b, b_1, b_2 =$ Wall thickness

Note:
Provide overlaps for splicing bars outside the corner, length of overlap to develop full bond say $50 d$.

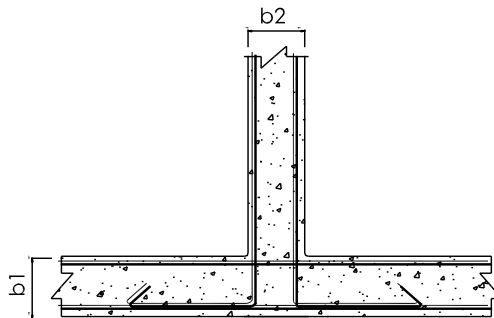

(b) R.C. band reinforcement details at corner and junction (links not shown)

Figure 10.7 (a): Details of Reinforcement in a Reinforced Concrete Band

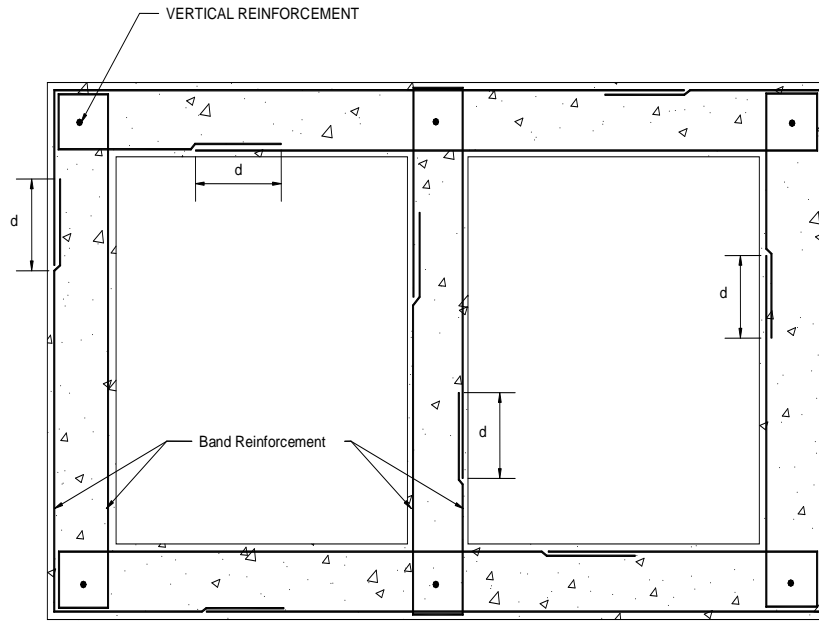

NOTE:

d - OVERLAPPING LENGTH min 700 mm.

Figure 10.7 (b): Details of Reinforcement in a Reinforced Concrete Band

10.3 Dowels at Corners and Junctions

In areas where steel and cement are available, steel dowel bars can be used at corners and T-junctions to assist the box action of walls. Dowels (**Figure 10.6**) shall be embedded in the walls to a sufficient length to develop their full bond strength. Details of this are shown in **Figure 10.8**.

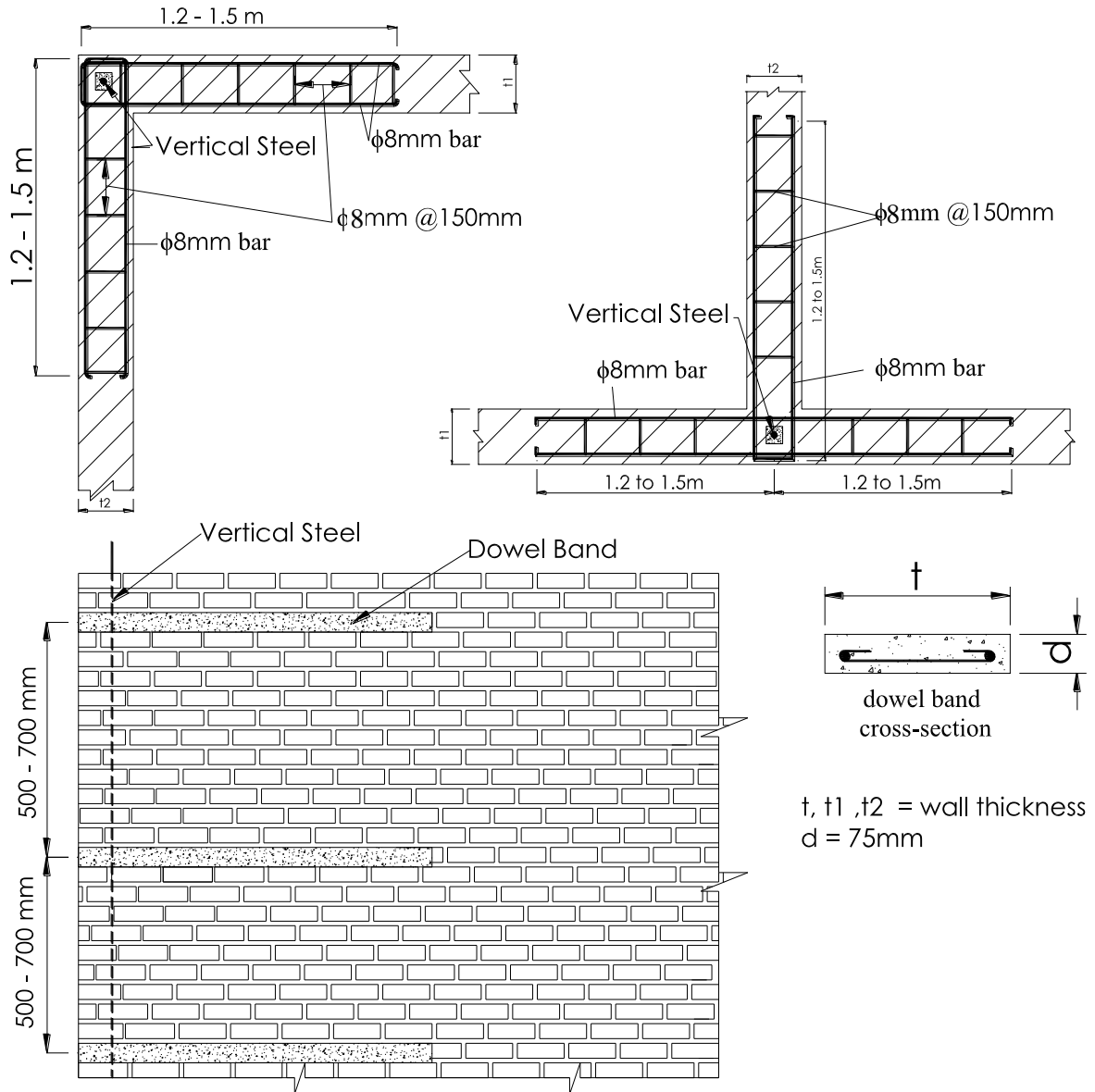
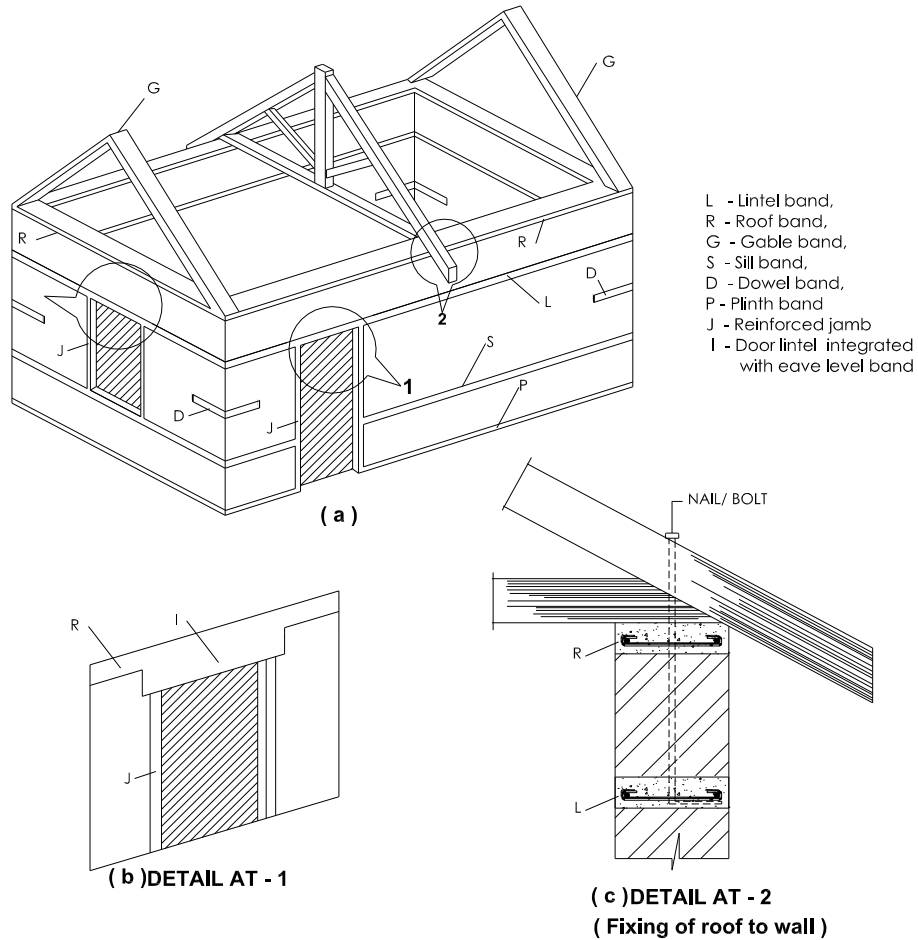

Figure 10.8: Corner and Junction Strengthening by Placing Dowel Reinforcement

10.4 Gable Band

Gable band must be used in all sloped-roof construction. They are constructed in a similar manner to horizontal bands. The difference is their position in the buildings. Gable bands are inclined members placed parallel to the inclination of the gable wall forming the roof slope. The details could be as illustrated in **Figure 10.9**.



Note:

i) As an alternative to the gable masonry, a truss or open gable may be used and the openings covered with a light material such as sheeting, matting etc.

ii) If the wall-height up to eave-level is less than or equal to 2.5 m, the lintel-level band may be omitted and the lintel integrated with the eave-level band (Roof-band) as shown in Detail 1.

Figure 10.9: Details for Gable Bands

10.5 Diagonal Bracing

All flexible structural elements such as joists and rafters shall be diagonally braced. Each crossings of joists/rafters and a braces shall be properly fixed. The bracing material could be timber strips, whole bamboo, or bamboo strips. The details could be as illustrated in **Figure 10.10**

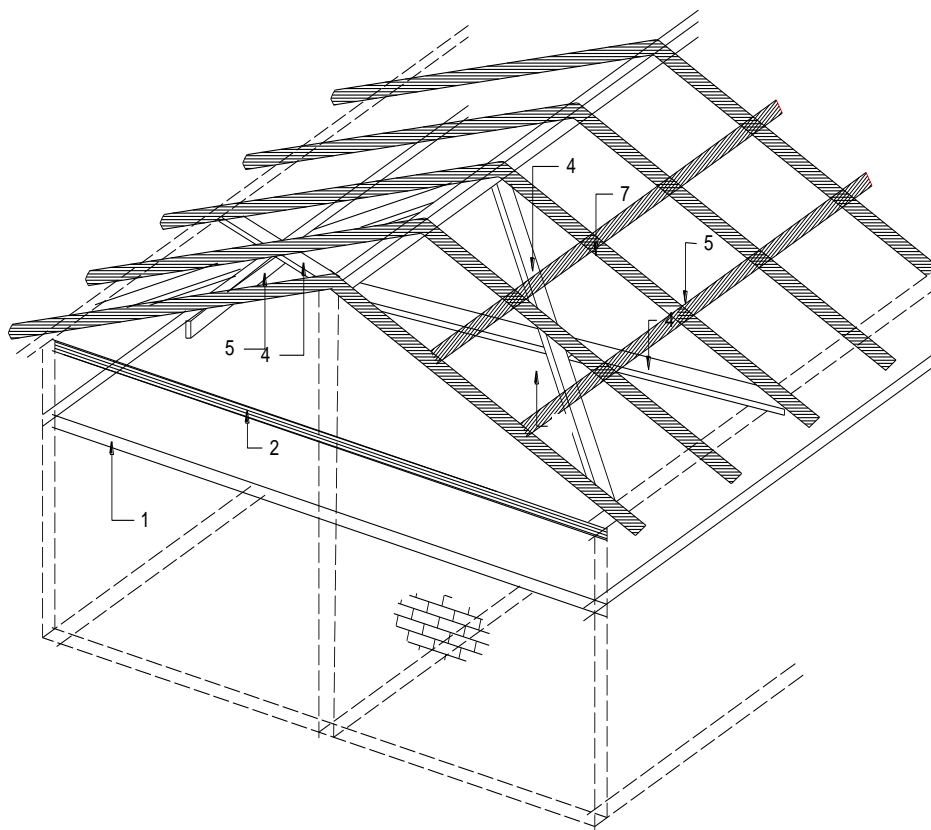

DETAILS OF NEW ROOF BRACING

1. FLOOR
2. GABLE WALL (TYMPANUM)
3. WOODEN NAIL NAILED TO NEW TIES 5 AND 2
4. NEW PLANKS, DIAGONAL BRACING
5. PURLINS
6. ROOF COVERING
7. ROOF RAFTERS
8. GABLE WALL TO BE FILLED WITH LIGHTER MATERIALS.

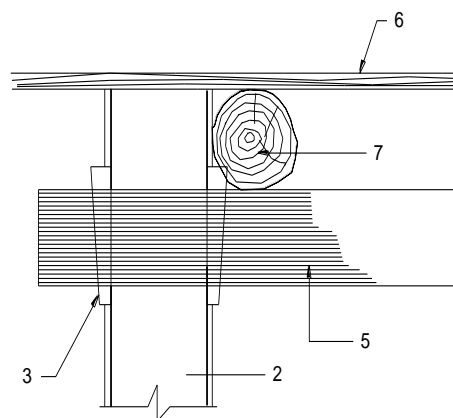

Figure 10.10: Details for Diagonal Bracing

10.6 Lateral Restrainers

When joists and beams are placed as detailed in section 9.1.2 and 9.1.4, the timber keys, along with the beams and rafters, work as lateral restrainers. Since they are effective in only one direction, only the walls normal to them are laterally restrained. For restraining the walls parallel to the joists, the wall plates or horizontal bands shall be extended beyond the exterior of walls to facilitate anchoring them by timber keys. This will partially restrain the walls parallel to the joists. Additional timber members should be provided above joists and normal to them. These elements shall be long enough to extend beyond the wall on the external side and at least cross two joists on the internal side. These elements shall be nailed to the joists and timber keys shall be provided on both the internal and internal faces of the wall. These timber elements shall have a maximum spacing of 450 mm. The details could be as given in **Figure 10.11**.

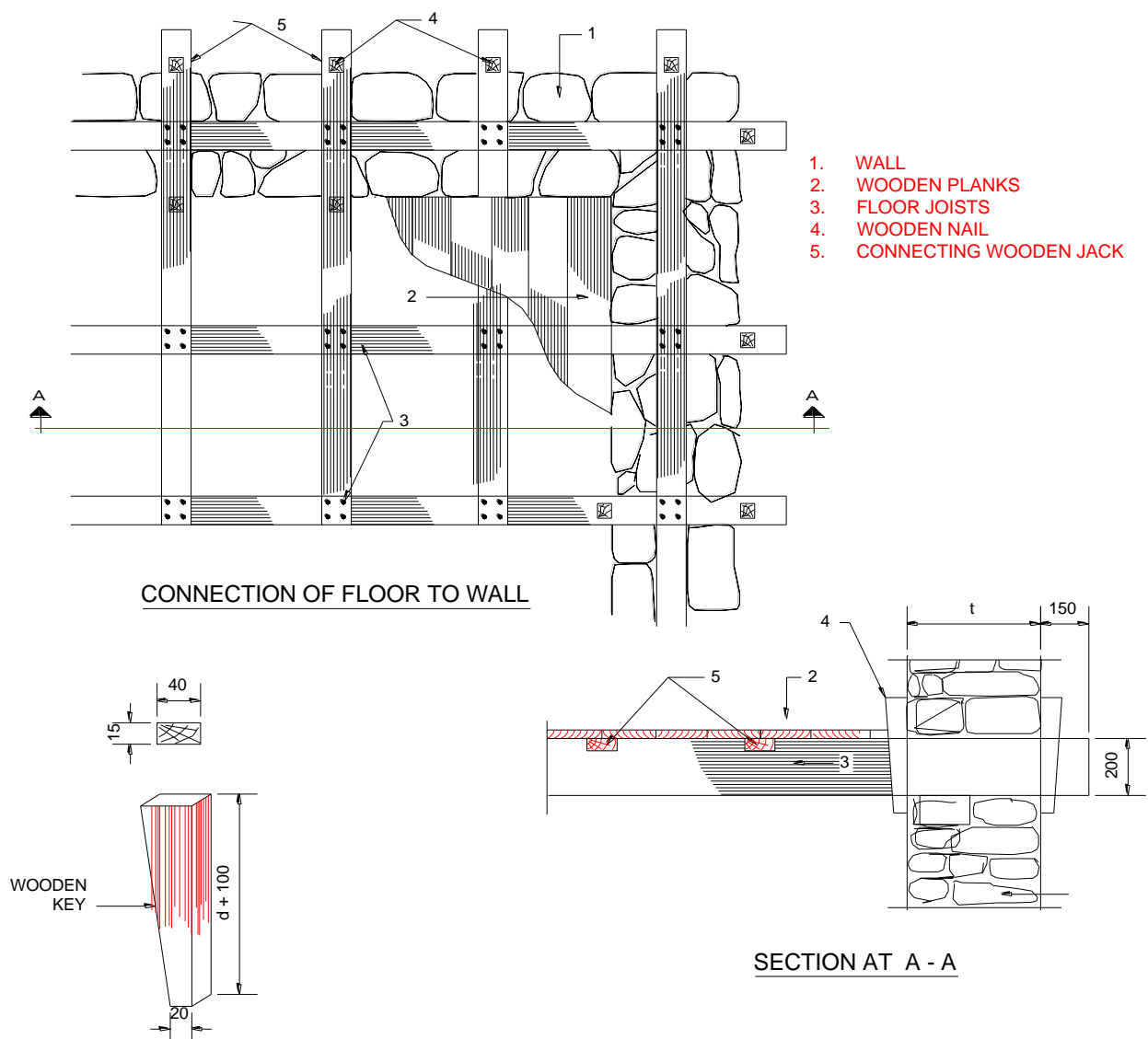

Figure 10.11: Lateral Restrainers

11 Miscellaneous

11.1 Damp Proof Course

Damp rising from the ground up into the superstructure not only damages the masonry units, but also accelerates the decaying of timber and bamboo elements. Damp rising through the floor makes it unhygienic. The rise of damp to the upper portion of the wall can be checked by inserting a damp-proof layer on the wall at the plinth level. In floors, a small quantity of clay is often used to reduce the rocking effect of stone slabs and to increase stability. The same layer, if continued beneath the entire flooring on the ground floor under the floor finish, makes the floor drier and thus more comfortable to live on. A damp-proof layer shall be placed at the plinth level as shown in **Figure 11.1**.

In areas where steel and concrete are available, reinforced concrete plinth beams with water-proofing compounds can be provided to achieve better damp-proofing.

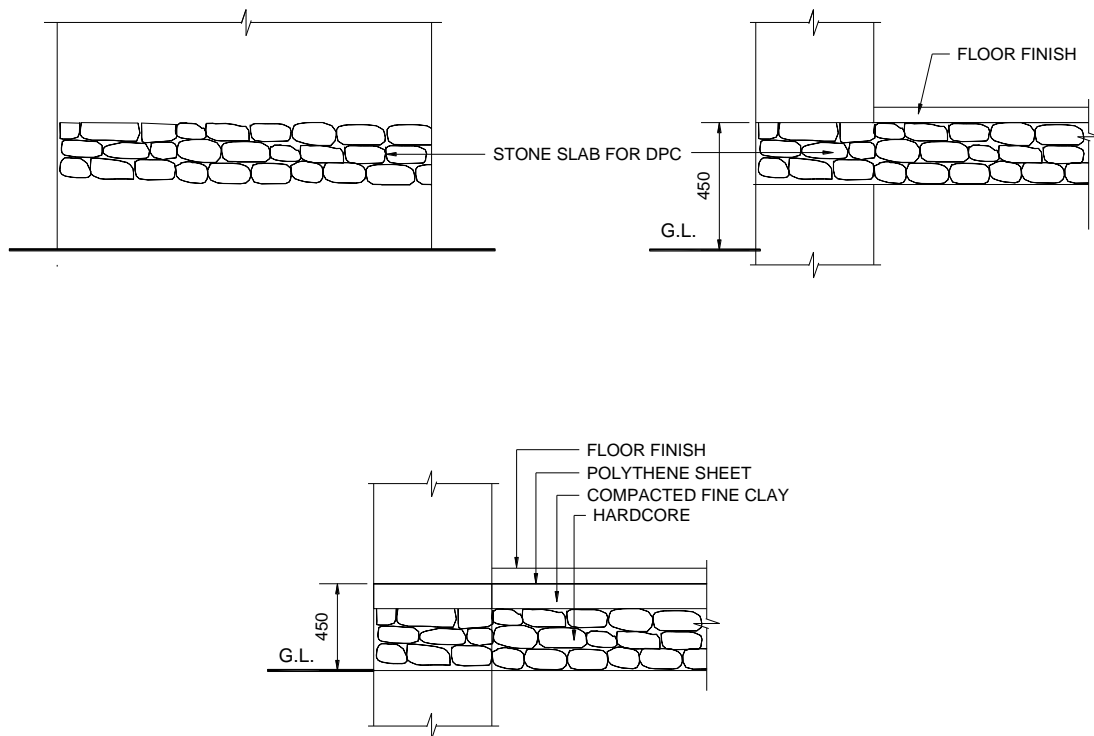

Figure 11.1(a): Damp-Proof Course (in areas where steel and concrete are not available)

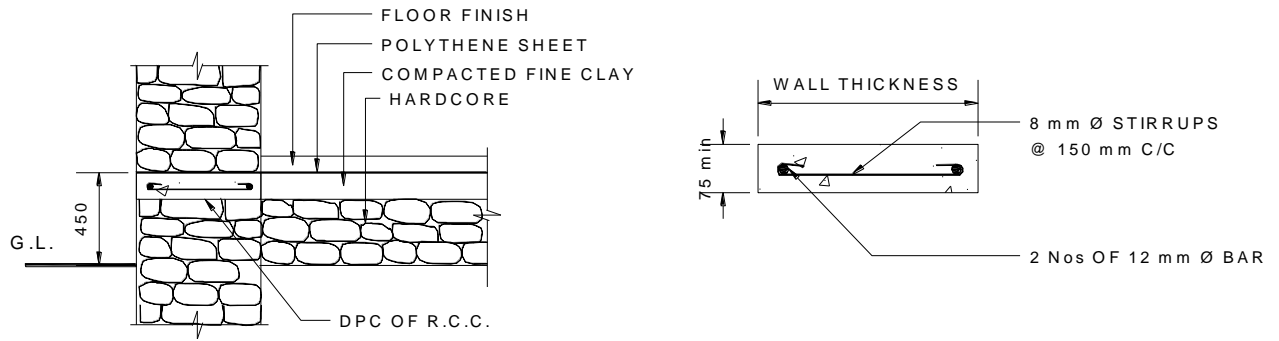

Figure 11.1(b): Damp-Proof Course (in areas where steel and concrete are available)

11.2 Drainage

Site drainage must be provided at the building site. If surface water is not properly drained away, it penetrates the foundation and upsets its stability. A proper drainage system shall be laid all around the building to prevent the penetration of surface water into the foundation. This shall be carried out as illustrated in **Figure 11.2**.

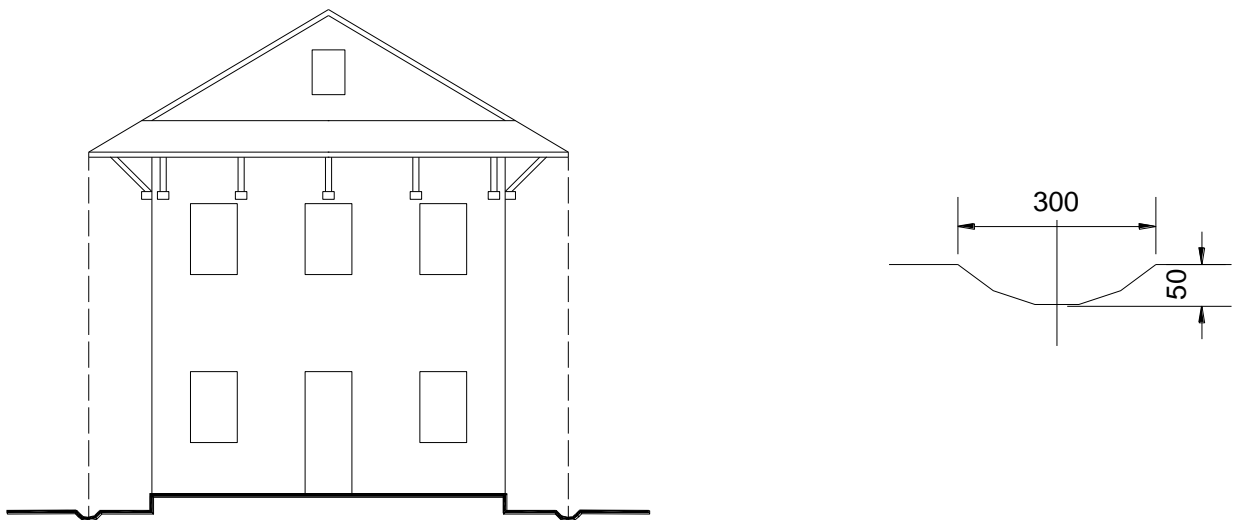

Figure 11.2: Surface Water Drainage around a Building

11.3 Plastering

Cement plaster can be applied to the walls after proper cleaning of the walls surface. The ratio of cement to sand shall not exceed 1:6.

APPENDIX - 1 HARVESTING AND PRESERVING BAMBOO FOR CONSTRUCTION

1 Harvesting and Preservative Treatment

1.1 Harvesting

Bamboo should be three-years old before harvesting. Cutting selectively at a rate determined by ecological conditions, and removing only mature culms three-years old, is the most natural procedure for maintaining a grove in a condition of sustained yield.

Harvesting guidelines prepared by Dehradun Forestry Institute (India) are applicable for Nepal as the climate, the location of Dehradun and other conditions are similar to those in Nepal.

Correct harvesting is very essential because proper and systematic harvesting gives a maximum life of cut bamboo for building component use. For some minor house component such as battens, the need for additional preservative treatment may be prevented if systematic harvesting was carried out.

1.1.1 Harvesting Guidelines

- Do not cut any clump younger than three years, or in the rainy season or from a flowering grove.
- No cuts shall be made lower than the second node or higher than 30 cm above ground.
- Remove branches, clump tips, and all harvest trash. Debris obstructs growth, encourages disease, and makes later harvesting more difficult.
- Leave leaves for mulch. Their 6 % silica helps harden later culms.
- A minimum of six mature culms should be left uncut in each clump of tropical species to sustain grove vitality and to insure a steady yield.

1.1.2 Clump Cure

Harvest bamboo at the beginning of the dry season; leave culms standing four to eight weeks in the groves, propped on stakes or rocks, with branches and leaves uncut so as to increase evaporation surface and diminish insect entry points offered by freshly cut skin. This clump cure not only reduces starch content, which the bamboo beetles seek, but it also greatly decreases the tendency to crack and produces a pleasing uniform colour on the culms. These points can be remembered by the saying "Battle beetles better with clump-cured culms".

1.2 Preservative Treatment

Deterioration by insects, rot, fungi and fire is the most serious drawback to bamboo as a building material. Traditional methods which are widely used to increase the durability of bamboo cost very little and can be carried out without any special equipment or technical knowledge. Harvesting and storing of bamboo in a proper way can increase the preservation of it considerably.

The following methods are most appropriate for use in Nepal. Natural preservation as when bamboo is used in smoky room is also suitable and cheap for some building components.

1.2.1 Water Leaching

The most common treatment for protecting bamboo from Bostrichidae and Letidae beetle attack is to leach out the starch, sugars and other water-soluble materials from the freshly-cut stem by submerging them in water. Removal of starch and sugar renders the bamboo unattractive to the beetles.

The bamboo must be completely under water, weighted down, if necessary, for periods ranging from three days to three months for freshly-cut bamboo and two weeks longer for partly-dry bamboo. Running water gives better results. Stagnant water sometimes leads to staining of the bamboo.

The susceptibility of bamboo to borer attacks depends on the species, its starch content, age of the column, felling season, and the physical properties of bamboo (Plank, 1950). But further studies indicate that starch content in bamboo is an important factor influencing the susceptibility to borer (Plank, 1950; 1951). The damage caused by borers has been found to be proportional to the starch content of the bamboo.

1.2.2 White Wash and Other Coatings

A variety of coatings appropriate for Nepal, such as tar, lime wash, tar and lime wash, and tar sprinkled with sand, may be used. However, these are effective only to the extent that they give a continuous coating at cut surfaces, exposed internodes, abrasion and slits.

1.2.3 Brushing, Swabbing, Spraying and Dipping

These surface treatments are adopted for bamboo in storage or before it is given impregnation treatments. Various chemicals are recommended for the protection of bamboo.

Dieldrin 0.05 percent, or aldrin 0.15 percent, in aqueous emulsion give almost complete protection against *Dinoderus* beetles for over a year. DDT, 7 to 10 % in kerosene oil and BHC, 0.2 percent, were even more effective. Spray application is recommended for stacks of bamboo.

Dipping green or partly dry bamboo for 10 minutes in a 5 % solution of DDT in fuel oil produced a highly-significant degree of control of the *Dinoderus* beetle for about 12 months. Soaking in the same solution for a longer period may result in protection for 24 to 30 months. For exposed bamboo where rainfall is likely, oil-borne insecticides should be prepared.

Except for treating large stocks, no expensive spraying equipment should be required for the prophylactic treatment of bamboo. Hand-operated sprayers should normally be suitable for protection against fungi and borers. A five-minute dip is recommended in a solution containing 2 % borax and 1 % pentachlorophenol in which 1 % is dispersed.

Other methods available, but these are more complex or costly and need careful processes. They include:

- Steeping, Boucherie process, stepping
- Capping Hot and cold bath process,
- Pressure treatment.

It should be noted that the water-leaching method seems to be the most relevant bamboo preservation technique for the Nepali situation. White wash and other coatings also suitable as Nepali people usually paint their houses annually during Dashain festival.

1.3 Fire Retardant Treatment

Although not much work has been done on the protection of bamboo against fire, it is possible to treat it with fire-retardant chemicals in the same way as wood. It is worthwhile to treat bamboo with the following fire-resistant cum antiseptic composition:

Ammonium Phosphate	-	3 parts
Boric Acid	-	3 parts
Copper Sulphate	-	1 parts
Zinc Chloride	-	5 parts
Sodium Dichromate	-	3 parts
Water	-	100 parts

A few drops of concentrated hydrochloric acid should be added to the solution to dissolve the precipitated salts.

1.4 Storage

Bamboo should be stacked horizontally on high, raised platforms, at least a foot above ground for the prevention of termite attack. Bamboo should be stored so that all sides can be readily and regularly inspected. Remove or treat attacked culms. At the storage yard, bamboo is air-seasoned under cover six to twelve weeks to increase strength and avoid cracking. Kiln seasoning can do the same job in two to three weeks, though at risk of splitting the outer membrane of several

species if the seasoning is too rapid.

To reduce fungal attack, guard bamboo against wetting by rain or contact with soil. Good ventilation and frequent inspection are important. The storage ground should be thoroughly inspected and cleaned before laying out the bamboo. All refuse and useless timber and bamboo should be removed.

Any termite-infested area of ground should be sprayed with 4 % emulsion of DDT or a 0.2 % emulsion of BHC or other suitable insecticide. Destroy termite colonies by breaking mounds open and pouring in insecticide. The ground should have good drainage facilities.

APPENDIX - 2 FIRE-RETARDANT TREATMENTS FOR THATCH ROOF

1 General

Obviously, an exposed thatch surface is vulnerable to fire hazards. If this surface is completely sealed with a thin incombustible layer, it becomes fire-retardant. Since the roof has to be exposed to atmosphere and subjected to rain, this thin layer has to be water-proof. Thus a layer of NEM plaster seems to be the simplest possible method.

1.1 Materials Required

- Mud
- Bhusa (chopped wheat or paddy straw)
- 80/100 grade bitumen
- Kerosene oil
- Cow-dung
- Firewood.
- Empty barrels for the melting and mixing of the bitumen.

1.2 Method of Preparation

The quantities of different materials given below will be sufficient for fire-retardant treatment for 100 m² of roof area.

1.2.1 Preparation of Stabilized Mud Mortar

- Collect three cubic meter of mud which contains 40 to 50 % sand and Clay 60 to 50 % of clay.
- Mix 180 kg chopped wheat or paddy straw with the mud. The wheat straw has to be chopped in 20 mm lengths, whereas rice straw may be up to 50 mm in length. Old straw is preferred to the fresh straw. Pour water over it and knead until the straw and mud becomes an uniform paste.
- Knead three to four times a day until the straw decomposes. The mix should not be allowed to dry during this process. It takes generally seven days in summer and 14 days in winter to decompose the straw.
- The stabilized mud mortar is then ready.

1.2.2 Preparation of Cut back₁ (for NEM)

- Collect 85 kg of bitumen and 17 liter of kerosene
- Heat bitumen till it melts.
- Pour the melted bitumen into Kerosene and keep stirring till it is thoroughly mixed. (Never pour Kerosene into bitumen.)

- The bitumen cut back₁ for NEM is ready.

1.2.3 Preparation of NEM mortar

- Mix 90 kg bitumen cut back₁ bitumen for NEM with the stabilized mud prepared as stated earlier. Knead thoroughly to a uniform homogeneous mortar.
- The NEM is ready for application

1.2.4 Preparation of Bitumen cut back₂ for Stabilized Mud Slurry

- Collect 20 kg of bitumen and 2 liter kerosene
- Heat bitumen till it melts.
- Pour the melted bitumen into kerosene and keep stirring until it is thoroughly mixed. (Never pour kerosene into bitumen)
- The cut-back₂ bitumen stabilized is ready.

1.2.5 Preparation of Stabilized Mud Slurry₁ for NEM

- Mix 0.1 cubic meters cow-dung and 0.1 cubic meters of mud. Knead thoroughly by adding water until the mixture becomes a thin paste.
- Add 12 kg of cut-back bitumen to this mixture and mix thoroughly.
- Make a uniform, homogeneous paste by constant stirring.
- Stabilized Mud Slurry₁ for NEM is now ready to use.

1.2.6 Preparation of Stabilized Mud Slurry₂ for Fire Retardant Plaster

- Mix 0.1 cubic meters cow-dung and 0.1 cubic meters of mud. Knead thoroughly by adding water until the mixture becomes a thin paste.
- Add 12 kg of bitumen cut back to this mixture and mix thoroughly.
- Make a uniform, homogeneous paste by constant stirring.
- Stabilized Mud Slurry₂ for Fire Retardant Plaster is now ready to use.

1.3 Method of Application

1.3.1 Dressing of Roof Surface

- Update all the connections by tying properly and add or replace thatch if necessary.
- When the roof surface has been made uniform, it is ready to receive fire- retarding plaster.

1.3.2 Application of Stabilized Mud plaster

- Start plastering with stabilized mud prepared as stated above. The plastering has to start from top and proceed towards the bottom.
- The thickness of this plaster should be enough to make the surface even and uniform such that it conceals all the bamboo strips and runners on top of the thatch covering.
- Allow this plaster to dry and crack for a day.
- Fill the cracks next day. When the plaster is dry, some more cracks may appear. Repeat the process until the whole wall surface becomes completely free of cracks.

1.3.3 Application of Stabilized Mud Slurry₁

- Make sure that the roof surface is free of cracks. Fill the cracks with NEM if existing and let it dry.
- Apply two coats of stabilized mud **Slurry₁** over the stabilized mud layer. The application can be either done by hand or with a brush.

1.3.4 Application of NEM plaster

- Start plastering with NEM, prepared as stated above, over the mud slurry₁. The plastering has to be started from top and continued towards the bottom.
- The average thickness of this plaster should be 12 mm. However, in the higher rain-fall areas, an additional 6 mm thickness NEM plaster has to be applied.
- Allow this plaster to dry and crack for a day.
- Fill the cracks next day. When the plaster is dry, some more cracks may appear. Repeat the process until the whole wall surface becomes completely free of cracks.

1.3.5 Application of Stabilized Mud Slurry₂

- Make sure that the roof surface is free of cracks. Fill the cracks with NEM if it already exist, and let it dry.
- Apply two coats of stabilized mud slurry₂ to the roof surface, over the NEM plaster. The application can be either be done by hand or with a brush.
- The roof is now fire-retardant. The application of stabilized mud slurry₂ has to be repeated every two to three years for regular maintenance of the NEM plaster.

It is essential to render all the edges and corners of the roof with the treatment, for better resistance to fire. The ceiling has to be plastered with a layer of stabilized mud prepared as stated above.

APPENDIX - 3 Reference Materials

1. "A Manual of Earthquake-Resistant Non-engineered Construction", Indian Society of Earthquake Technology, University of Roorkee, India.
2. "Protection of Educational Buildings Against Earthquakes," Prof. A. S. Arya.
3. "School Construction Manual", HMG/UNCHS (Habitat), Kathmandu, Nepal
4. "Live Better with Mud and Thatch", CBRI, Roorkee, India.
5. "Earthquake-Resistant Measures for Small Buildings", EAARRP, MHPP, HMG Nepal.
6. "Detailer's Manual for Small Buildings in Seismic Areas", Teddy Boen, Indonesia.
7. Bamboos: Field manual for community and private forestry in Nepal, Part 2, Edited and Compiled by I.J. McCracken HMG/FAO/UNDP community Forestry Development Project F.D. Ni. 20-1992

APPENDIX - 4 GLOSSARY

The following terms used in this document are explained below:

ABRASION means surface-wearing of a material due to friction with another material/materials in contact.

ADOBE means sun-dried clay brick work with mud mortar.

ADVISORY means suggestion (of better construction techniques, materials, etc.) as opposed mandatory rules whose enforcement is assured by law. Non-observance of "Advisory" rules will be harmful to the owner.

ANCHORED means fixed with devices like nails, bolts, hooks etc. for ensuring better load transfer.

ASYMMETRIC means of a plan or section or a view which does not have a similar half.

BAMBOO GROVES means group/groups of bamboo trees at the particular place where they are growing naturally.

BASE PAD means a member of a relatively stronger material provided at the base end of a beam / post so as to transfer the load into a wider area so that damage of the wall/support due to local point load effect is avoided.

BEARING means a supporting base material provided at the end of beams / joists to reduce the concentrated load effect.

SEISMIC RESISTANT CONSTRUCTIONS means constructions in which the earthquake resistant structural and non-structural elements are incorporated.

BOSTRICHIDAE means a kind of beetle (insect) that attacks the bamboo.

BOX EFFECT means the condition of a building in which it behaves like a single unit. Various elements like horizontal and vertical reinforcements, diagonal bracing and lateral restrainers etc. can bring about this effect.

BRIDGING MATERIALS means materials used for tying two or more joists to enhance integrity of individual joists.

CGI SHEETS means corrugated galvanized iron sheets mostly used as roofing material.

MUD WALL means wall constructed with kneaded lump of mud and compacted.

CULMS means a single unit of bamboo tree

DALAN means a one side open enclosure on the ground floor of a rural building usually in front face of the building.

DAMP PROOF COURSE means a relatively dense course with water proofing material provided below the plinth level on the wall or side of the building to prevent migration of the damp.

DECIDUOUS TREES means trees that lose their leaves annually usually in autumn.

DIAGONAL BRACING means the bracing of wall or other members fixed diagonally at appropriate positions.

DINODERUS BEETLES means a kind of beetles that attacks bamboo.

EMBEDDED means placed firmly such that the bond is ensured.

FIRE RETARDANT means material or process that decelerates the fire affinity.

FLEXIBLE STRUCTURES means structures that do not have sufficient rigidity to resist deflection.

FUNGAL ATTACK means a kind of infection (by the fungi).

GABLE BAND means a continuous band provided on the gable wall end to alleviate falling of gable wall during earthquake.

GEOLOGICAL FAULT LINES means geological discontinuity lines on the ground surface that may cause earthquakes.

HAZARDOUS means area or situation that deserves likely damage or destruction.

HORIZONTAL BAND means a continuous member that may be of wooden or bamboo or reinforced cement concrete provided at plinth, lintel and roof level as required.

INSECTICIDE means chemicals that kill insects.

JHINGATI means traditional local burnt clay tiles for roofing usually of small size

LAND SUBSIDENCE means relative upheaval or lowering of land with respect to the adjacent land.

LATERAL RESTRAINERS means elements provided to restrain the walls laterally in horizontal direction (usually wooden keys) to keep walls at position during horizontal load.

LATERALLY ESTRAINTS means condition of lateral resistance to falling.

LIQUEFACTION means a ground condition at which the soil completely loses the load bearing capacity and flows like liquid and the foundation sinks in to the ground. It mostly occurs in saturated sand layer.

LYETIDAE means a kind of beetles that attack bamboo.

MANDATORY means rule and regulations that are governed by a mandate and shall not be offended.

MARSHY means low lying wet land.

METH (CAPITAL) means a member of relatively larger surface area provided at supporting surface to distribute the load uniformly to the supporting posts

MICRO CONCRETE ROOFING (MCR) means roofing tiles having projected binding wires embedded in to the tiles for anchoring.

MUD SLURRY means mud mixed with water so as to make as liquid to semi-liquid.

NATURAL HAZARDS means hazards caused by the nature itself. For example landslide, flood, earthquake etc.

PLINTH means raised level of floor from the ground in a building to improve hygienic conditions in building.

PLUMB LINE means the vertical line shown by a plum bob (an object with weighty material at the end and hung with a string)

PRESERVATIVE TREATMENT means treatment made to timber or bamboo to preserve from insects or decaying.

PROPHYLACTIC means tending to prevent a disease or attack from harmful insects.

RUPTURE LINES means the lines of failure of an object.

SAP WOOD means a soft layer of wood between the bark and the inside hardcore.

SEISMIC SAFETY means safety level against the earthquake damage.

SILL means bottom level of an opening on the wall.

SOFT STOREY EFFECT means a poor structural behavior of a storey in a building in which a particular lower storey has lesser rigidity than the stories above it.

STRUTS means cross ties provided between two main elements to maintain their integrity and rigidity.

SUPERSTRUCTURE means the structure above the plinth level such as walls, roofs etc.

SWABBING means process of cleaning the bamboo or timber with cotton cloths.

SWAMP means soft wet land in which foundation should be erected only after proper treatment.
TERMITES means small insect, found chiefly in tropical areas, that is very destructive to timber (popularly called white ant)

TERMITE INFESTED AREA means area where the termite are living, growing and cause damage to timber or bamboo where they are living.

UN-STIFFENED means members that are not strengthened or has the less stiffness.

UNBALANCED OPENINGS means the opening not being in proper places and stories that may cause unbalanced stiffness or soft storey effect.

UNSUPPORTED WALL LENGTH means the wall length without the buttresses or cross walls provided to reduce damage.

VERNACULAR BUILDINGS means traditional buildings constructed in a locality.

VERTICAL REINFORCEMENT means the vertical ductile element provided to increase the ductility of structure.

VULNERABILITY means vulnerability is the ratio of expected loss to the maximum possible loss.

VULNERABLE means a structure is said to be vulnerable if the damage is expected at a given hazard.

WATER REPELLANT means materials that repel or show no affinity to water.

WATER LOGGED means area saturated with water possessing lack of drainage.

WATER LEACHING means process of treating timber or bamboo in water to raise its resistance to termites and beetles by leaching out starches, sugar etc.

NEM non-erodible mortar (mortar that is not easily erodible by rain water)

Personnel involved in the preparation of the 1st version of this code (NNBC 203: 1994 Guidelines for Earthquake Resistant Building Construction: Low Strength Masonry)

The Advisory Panel consisted of :

Mr. UB Malla, Joint Secretary, MHPP Director General, Department of Building (Mr. LR Upadhyay)	Chairman
Mr. AR Pant, Under Secretary, MHPP Director General, Department of Mines & Geology (Mr. PL Shrestha)	Member
Mr. AR Pant, Under Secretary, MHPP Director General, Department of Mines & Geology (Mr. PL Shrestha)	Member
Director General, Nepal Bureau of Standards & Metrology (Mr. PB Manandhar)	Member
Dean, Institute of Engineering, Tribhuvan University (Dr. SB Mathe)	Member
Project Chief, Earthquake Areas Rehabilitation & Reconstruction Project	Member
President, Nepal Engineers Association	Member
Law Officer, MHPP (Mr. RB Dange)	Member
Representative, Society of Consulting Architectural & Engineering Firms (SCAEF)	Member
Representative, Society of Nepalese Architects (SONA)	Member
Deputy Director General, Department of Building, (Mr. JP Pradhan)	Member-Secretary

The Subcontractor was BECA WORLEY INTERNATIONAL CONSULTANTS LTD. of New Zealand in conjunction with subconsultants who included :

Golder Associates Ltd., Canada
SILT Consultants P. Ltd., Nepal
TAEC Consult (P.) Ltd., Nepal
Urban Regional Research, USA

Principal inputs to the standard came from :

Mr. YK Parajuli, TAEC
Mr. JK Bothara, TAEC
Mr. SL Sharma, TAEC
Mr. BK Upadhyay, TAEC
Dr. AS Arya, Professor Emeritus, University of Roorkee
Ms J Preuss, URR
Mr. J Preuss, URR

Revisions and Updated to the code came from:

Mr. Purna P. Kadariya, DG, DUDBC
Mr. Kishore Thapa, DDG, DUDBC
Mr. Mani Ratna Tuladhar, Sr. Div. Engineer, DUDBC
Mr. Jyoti Prasad Pradhan, Ex. DG, DOB
Mr. Bhubaneswar Lal Shrestha, Ex. DDG, DOB
Mr. Uttam Shrestha, Architect, Architects' Module Pvt. Ltd.
Mr. Manohar Lal Rajbhandari, Sr. Structural Engineer, MR Associates
Mr. Amrit Man Tuladhar, Civil Engineer, DUDBC

Personnel involved in the first revision of this code: (NNBC 203: Guidelines for Earthquake Resistant Building Construction: Low Strength Masonry)

Dr. Ramesh Prasad Singh, Secretary, WECS, GoN
Mr. Shiva Hari Sharma, Director General, DUDBC, MOUD
Mr. Sambhu K.C, Joint Secretary, MOUD
Mr. Maniram Gelal, Deputy Director General, DUDBC, MOUD
Mr. Dwarika Shrestha, Joint Secretary, MOUD
Mr. Sagar Krishna Joshi, former SDE, DUDBC, MOUD
Mr. Ganesh Prasad Pathak, Nepal Bureau of Standards and Metrology
Dr. Prem Nath Maskey, I.O.E, TU
Dr. Purushottam Dangol, ERTech
Dr. Jishnu Subedi, CORD
Dr. Haridarshan Shrestha, CORD
Dr. Santosh Shrestha, NHSSP
Mr. Nabin Malakar, Civil Icon Consultancy Pvt. Ltd.
Mr. Prakirna Tuladhar, SDE, DUDBC, MOUD
Mr. Machakaji Maharjan, SDE, DUDBC, MOUD
Mr. Suman Salike, SDE, MOUD
Mrs. Mina Shrestha, SDE, DUDBC, MOUD
Mr. Himal KC, SDE, DUDBC, MOUD
Mr. Parikshit Kadaria, SDE, DUDBC, MOUD
Mr. Manoj Nakarmi, SDE, DUDBC, MOUD
Mr. Pravin Shah, SDE, DUDBC, MOUD
Mr. Ganesh Karmacharya, SDE, DUDBC, MOUD
Mr. Lila Khatiwada, SDE, DUDBC, MOUD
Mr. Binay Charan Shrestha, former SDE, DUDBC, MOUD
Mr. Ramchandra Thapa, Engineer, DUDBC, MOUD
Mr. Surendra Vaidya, Engineer, DUDBC, MOUD
Mr. Bivek Sigdel, Engineer, MOUD
Mr. Chandra Kaji Gurung, Engineer, DUDBC, MOUD
Mr. Debendra Dev Khanal, Engineer, DUDBC, MOUD